

Electric-Powered
8 & 17 Series
Two-Stage Hydraulic Pump



Table of Contents

Description	2
PE8/17-Series Electric / Hydraulic Pumps	2
Control Valves	3
Safety Symbols and Definitions	5
Safety Precautions	5
Initial Setup	9
Operating Instructions	12
Performance Specifications	14
General Maintenance	15
Troubleshooting Guide	18
Power Team Facilities	21

Description

The 17 series hydraulic pumps are designed to have a maximum of 690 bar (10,000 psi) at a flow rate of 278 cc/min (17 cu. in/min). A pump can be valved for use with either single- or double-acting cylinders.

The 8 series pump all the same features as the 17-series. The 8-series is equipped with a 1.9 kW (½ HP) 1,725 RPM electric motor where the 17-series is equipped with a 1.9 kW (½ HP) 3,450 RPM electric motor. All pumps come fully assembled, less fluid, and ready for work.

PE8/17-Series Electric / Hydraulic Pumps

The 17 series uses an induction motor. Refer to the *Performance* section of this manual for motor ratings.

Electric Motor

The PE17-series pumps are equipped with .4 kW (1/2 hp), 3,450 rpm, single-phase, thermal protected induction motor; 10 ft. remote control cord. Low amperage draw; small generators and low amperage circuits can be used as power source. Extremely quiet noise level (67-81 dBA).

The PE8-series pumps are equipped with 1,725 rpm, single-phase, thermal protected induction motor.



Figure 1. PE172SM



Figure 2. PE84

Control Valves

Max. Capacity: 690 Bar (10,000 PSI)

	Valve Function	Use with Cylinder Type	Valve No.
PE84 PE174	<p>POSITION "A"</p>  <p>CENTER POSITION</p>  <p>POSITION "B"</p> 	Single-and double-acting	9500 4-way, 3-position, pump mounted manual detented
	<p>Diagrams</p> 		
PE172 PE172M	<p>HOLD PUMP "OFF" HOLD POSITION</p>  <p>ADVANCE PUMP "ON" HOLD POSITION</p>  <p>RETURN PUMP "OFF" RETURN POSITION</p> 	Single acting	9517 2-way, 2-position, pump mounted manual detented
	<p>Diagrams</p> 		
PE172S PE172SM	<p>ADVANCE PUMP "ON" SOLENOID DE-EMERGIZED</p>  <p>HOLD PUMP "OFF" SOLENOID DE-EMERGIZED</p>  <p>RETURN PUMP "OFF" SOLENOID EMERGIZED</p> 	Single acting	9579 3-way, 2-position, pump mounted solenoid operated, normally closed
	<p>Diagrams</p> 		

Table 1. Pump Configurations

Control Valves continued

PE172A PE172AM	Valve Function		Use with Cylinder Type	Valve No.
	<div style="display: flex; justify-content: space-around;"> <div style="text-align: center;"> <p>ADVANCE PUMP "ON"</p>  <p>From Pump</p> </div> <div style="text-align: center;"> <p>RETURN PUMP "OFF"</p>  <p>To Tank</p> </div> </div>	Single acting	45554 Auto/Dump manifold advance return	
Diagrams				
				

Table 1. Pump Configurations (continued)

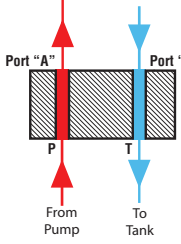
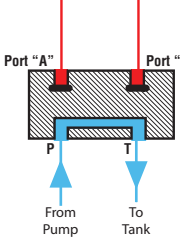
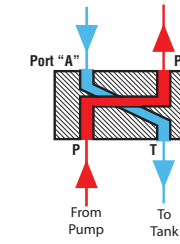
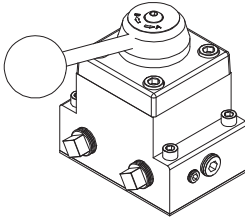
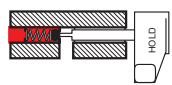
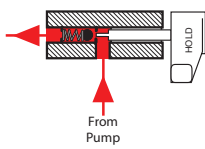
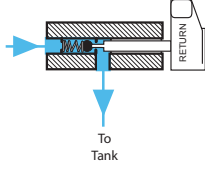
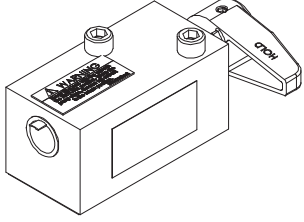
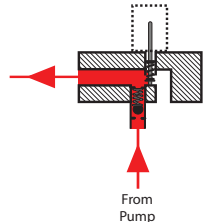
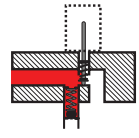
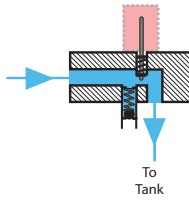
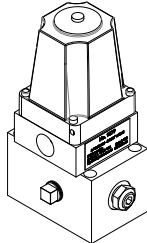
Safety Symbols and Definitions

The safety signal word designates the degree or level of hazard seriousness.

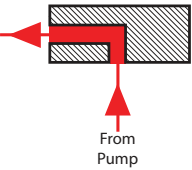
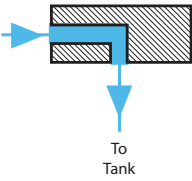
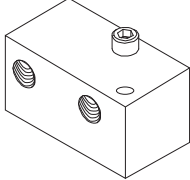

DANGER: Indicates an imminently hazardous situation which, if not avoided, will result in death or serious injury.



WARNING: Indicates a potentially hazardous situation which, if not avoided, could result in death or serious injury.



CAUTION: Indicates a potentially hazardous situation which, if not avoided, may result in minor or moderate injury.

CAUTION: Used without the safety alert symbol indicates a potentially hazardous situation which, if not avoided, may result in property damage.

IMPORTANT: Important is used when action or lack of action can cause equipment failure, either immediate or over a long period of time.

Safety Precautions



WARNING:



- The following procedures must be performed by qualified, trained personnel who are familiar with this equipment. Operators must read and understand all safety precautions and operating instructions included with the pump. If the operator cannot read these instructions, operating instructions and safety precautions must be read and discussed in the operator's native language.

- These products are designed for general use in normal environments. These products are not designed for lifting and moving people, agri-food machinery, certain types of mobile machinery, or in special work environments such as: explosive, flammable, or corrosive. Only the user can decide the suitability of this product in these conditions or extreme environments. Power Team will supply information necessary to help make these decisions. Consult your nearest Power Team facility.



- Safety glasses must be worn at all time by the operator and anyone within sight of the unit. Additional personal protection equipment may include: face shield, goggles, gloves, apron, hard hat, safety shoes, and hearing protection.



- The owner of this tool must ensure that safety-related decals are installed, maintained, and replaced if they become hard to read.



- Shut OFF the motor before opening any connections in the system.
- The guide cannot cover every hazard or situation so always do the job with SAFETY FIRST.

Pump



WARNING:

- Do not exceed the hydraulic pressure rating noted on the pump nameplate or tamper with the internal high pressure relief valve. Creating pressure beyond rated capacities can result in personal injury.
- Retract the system before adding fluid to prevent overfilling the pump reservoir. An overfill can cause personal injury due to excess reservoir pressure created when cylinders are retracted.
- The load must be under operator control at all times.

Safety Precautions continued

- Do not connect pump to hydraulic system powered by another pump.

Electric Motor



WARNING:

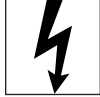

- Electrical work must be performed and tested by a qualified electrician per local directives and standards.
- Disconnect the pump from the power supply and relieve pressure before removing the motor case cover or performing maintenance or repair.
- Check the total amperage draw for the electrical circuit you will be using. *For example: Do not connect a pump that may draw 25 amps to a 20 amp fused electrical circuit.*
- Never use an ungrounded power supply with this unit.
- Changing the voltage is an involved and, if incorrectly performed, hazardous procedure. Consult the manufacturer for specific information before attempting rewiring.
- Wire pump motors for counterclockwise rotation when viewed from the shaft end of the motor.



- Do not attempt to increase the power line capacity by replacing a fuse with another fuse of higher value. Overheating the power line may result in fire.
- Exposing electric pumps to rain or water could result in an electrical hazard.
- Avoid conditions that can cause damage to the power cord, such as abrasion, crushing, sharp cutting edges, or corrosive environment. Damage to the power cord can cause an electrical hazard.

Hoses



WARNING:



- Before operating the pump, tighten all hose connections using the correct tools. Do not overtighten. Connections should be only secure and leak-free. Overtightening can cause premature thread failure or high pressure fittings to split at pressures lower than their rated capacities.
- Should a hydraulic hose rupture, burst, or need to be disconnected, immediately shut off the pump and shift the control valve twice to release pressure. Never attempt to grasp a leaking hose under pressure with your hands. The force of escaping hydraulic fluid could cause serious injury.
- Do not subject the hose to potential hazard, such as fire, sharp surfaces, heavy impact, or extreme heat or cold. Do not allow the hose to kink, twist, curl, or bend so tightly that the fluid flow within the hose is blocked or reduced. Periodically inspect the hose for wear, because any of these conditions can damage the hose and possibly result in personal injury.
- Do not use the hose to move attached equipment. Stress can damage the hose and possibly cause personal injury.



- Hose material and coupler seals must be compatible with the hydraulic fluid used. Hoses also must not come in contact with corrosive material such as creosote-impregnated objects and some paints. Consult the manufacturer before painting a hose. Never paint the couplers. Hose deterioration due to corrosive materials may

result in personal injury.

- **Avoid straight line tubing connections in short runs. Straight line runs do not provide for expansion and contraction due to pressure and/or temperature changes.**
- **Eliminate stress in the tube lines. Long tubing runs should be supported by brackets or clips. Tubes through bulkheads must have bulkhead fittings. This makes easy removal possible and helps support the tubing.**
- **Carefully inspect all hoses and fittings prior to use. Before each use, check entire hose for cuts, leaks, abrasion or bulging of cover, or damage or movement of couplings. If any of these conditions exist, replace the hose immediately. NEVER attempt to repair the hose.**

Cylinder



DANGER:

- **Do not exceed rated capacities of the cylinders. Excess pressure may result in personal injury.**
- **Avoid off-center loads that could damage the cylinder and/or cause loss of the load.**
- **Read and understand all safety and warning decals and instructions for devices attached.**
- **Inspect each cylinder and coupler before each shift or usage to prevent unsafe conditions from developing.**
- **Do not use cylinders if they are damaged, altered or in poor condition.**
- **Do not use cylinders with bent or damaged couplers or damaged port threads.**
- **Under certain conditions, the use of an extension with a hydraulic cylinder may not be advisable and could present a dangerous condition.**
- **Avoid pinch points or crush points that can be created by the load or parts of the cylinder.**
- **To help prevent material fatigue if the cylinder is to be used in a continuous application, the load should not exceed 85% of the rated capacity or stroke.**
- **Cylinder must be on a stable base which is able to support the load while pushing or lifting.**
- **To help prevent personal injury, use shims, friction material or constraints to prevent slippage of the base or load.**
- **Do not set poorly-balanced or off-center loads on a cylinder.**
- **The load can tip or the cylinder can “kick out” and cause personal injury.**
- **Do not use the locking collar on a threaded piston as a stop. The threads may shear resulting in loss of the load.**
- **If this component is used to lift or lower loads, be certain that the load is under operator control at all times and that others are clear of the load.**
- **Do not drop the load.**
- **As the load is lifted, use blocking and cribbing to guard against a falling load.**
- **To help prevent personal injury, do not allow personnel to go under or work on a load before it is properly cribbed or blocked. All personnel must be clear of the load before lowering.**



Safety Precautions continued

- **Never use extreme heat to disassemble a hydraulic cylinder or ram. Metal fatigue and/or seal damage will result and can lead to unsafe operating conditions.**

IMPORTANT

- **Keep the cylinder clean at all times.**
- **While at a job site, when the cylinder is not in use, keep the piston rod fully retracted and upside down.**
- **Always use protective covers on disconnected quick couplers.**
- **When mounting cylinders or rams using the internal piston rod threads, collar threads, threaded tie rods or base mounting holes, the threads must be fully engaged. Always use SAE grade 8 or better fasteners when attaching components to cylinders or rams and tighten securely.**
- **Limiting the stroke and pressure on all cylinders will prolong their life.**

Initial Setup

1. Remove all packing materials from the assembled unit.
2. Inspect the unit upon arrival. The carrier, not the manufacturer, is responsible for any damage resulting from shipment.

Filling the Pump Reservoir

Most pumps are shipped without hydraulic fluid in the reservoir. Hydraulic fluid may have been shipped in a separate container, but if hydraulic fluid is needed, use only approved Power Team hydraulic fluid rated at AW 46 47 cSt @ 38°C (215 SUS @ 100°F). If low temperature requirements are needed, use hydraulic fluid 5.1 cSt @ 100°C (451 cSt @ -40°C).

1. Clean the area around the filler cap to remove debris. Debris in the hydraulic fluid can damage the polished surfaces and precision-fit components of this pump.
2. Remove the filler cap and insert a clean funnel with a filter.
3. Fill the reservoir with hydraulic fluid to 1.3–3.8 cm (0.5–1.5 in.) from the cover plate.
4. Replace the filler cap. Verify the breather-hole is open, if applicable.

NOTE: If hydraulic fluid foaming becomes a problem, reduce the hydraulic fluid level to 2" below the cover plate.

Hydraulic Connections

1. Clean the areas around the fluid ports of the pump and cylinders.
2. Inspect all threads and fittings for signs of wear or damage, replace as needed.
3. Clean all hose ends, couplers or union ends.
4. Remove the thread protectors from the hydraulic fluid outlets.
5. Connect the hose assembly to the hydraulic fluid outlet, and couple the hose to the cylinder.



CAUTION: To prevent personal injury from leaking hydraulic fluid, seal all hydraulic connections with a high-quality, non-hardening, pipe thread sealant.



IMPORTANT: Sealant tape or non hardening sealer tape can be used to seal hydraulic connections if only one layer of tape is used. Apply tape carefully, two threads back, to prevent it from being pinched by the coupler and broken off inside the system. Loose pieces of sealant could travel through the system and obstruct the flow of fluid or cause jamming of precision-fit parts.

Electric Motor Operation

Motor voltages are not changeable. They are:

12 VDC - 11-14 VDC

120 VAC - 90-130 VAC 50/60 Hz

220 VAC - 190-240 VAC 50/60 Hz

1. Verify the valve is in the neutral or hold position.
2. Connect the motor to a power supply.

Caution:

- **The correct voltage is required for the pump to operate. Verify the voltage rating on the pump motor name plate matches the outlet or power source you are using. Low voltage may cause: an overheated motor; a motor that fails to start under load; motor surging when trying to**

Initial Setup continued

start; or a stalled motor before maximum pressure is reached.

- Check the voltage at the motor with the pump running at full pressure.
 - Never run the motor on long, light gauge extension cords. Refer to Table 2. Minimum Recommended Gauge Table.
3. Start the pump and shift as required.
 4. Turn off the pump when not in use.

AMPS at Maximum Hyd. Pressure	Electrical Cord Size AWG (mm ²) 3.2 Volt Drop Length of Electrical Cord							
	mm ²				AWG			
	0-8 m	8-15 m	15-30 m	30-46 m	0-25 ft	25-50 ft	50-100 ft	100-150 ft
6	0.75	1	1.5	2.5	18	16	14	12
10	0.75	1.5	2.5	4	18	14	12	10
14	1	2.5	4	6	16	12	10	8
18	1.5	2.5	6	6	14	12	8	8
22	1.5	4	6	10	14	10	8	6
26	2.5	4	6	10	12	10	8	6
30	2.5	4	10	16	12	10	6	4

Table 2. Minimum Recommended Gauge Table

Bleeding Air from the System

After all connections are made, the hydraulic system must be bled of any trapped air. Refer to Figure 3. With no load on the system and the pump vented and positioned higher than the hydraulic device, cycle the system several times. If you are in doubt about venting your pump, read the operating instructions for your pump. Check the reservoir fluid level and fill to proper level with Power Team hydraulic fluid as necessary. If there is a problem contact the Power Team.

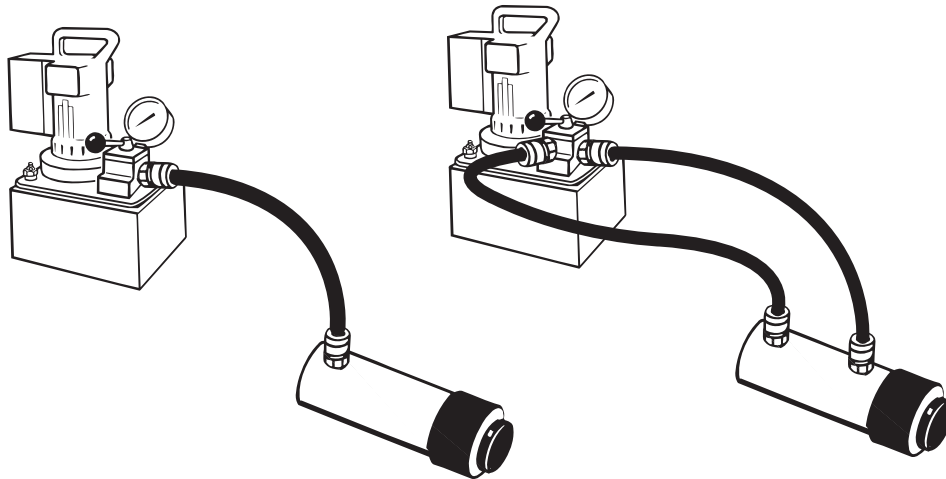

Figure 3. System Bleeding

IMPORTANT: Some spring return cylinders or rams have a cavity in the rod which forms an air pocket. This type of cylinder or ram should be bled when positioned upside down or lying on its side with the port facing upward.

Hydraulic Pressure Gauge (optional)

Automatic Dump Valve

To monitor line pressure when using an automatic dump valve, a tee fitting is used between the valve and the pressure switch to adapt a hydraulic pressure gauge.

Posi-Check Valve

If a Posi-Check valve is used, a hydraulic gauge shows zero pressure when the valve is switched to the neutral (hold) position. Cylinder pressure, however, is held without loss.

To install a hydraulic pressure gauge:

1. Refer to Figure 4. Remove the pipe plug from the valve's gauge port.

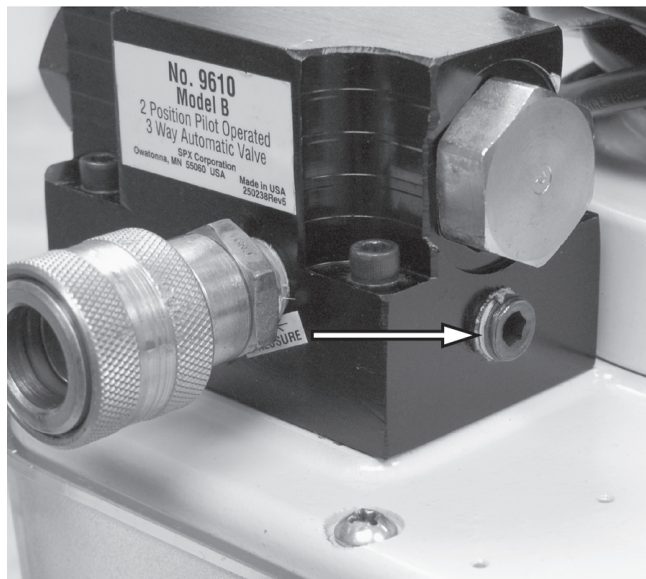

Figure 4. Gauge Port

2. Refer to Figure 5. Install sealant tape or non hardening sealer to a 45 degree elbow (PN 9678). Install the elbow as shown.
3. Install sealant tape or non hardening sealer to the gauge.

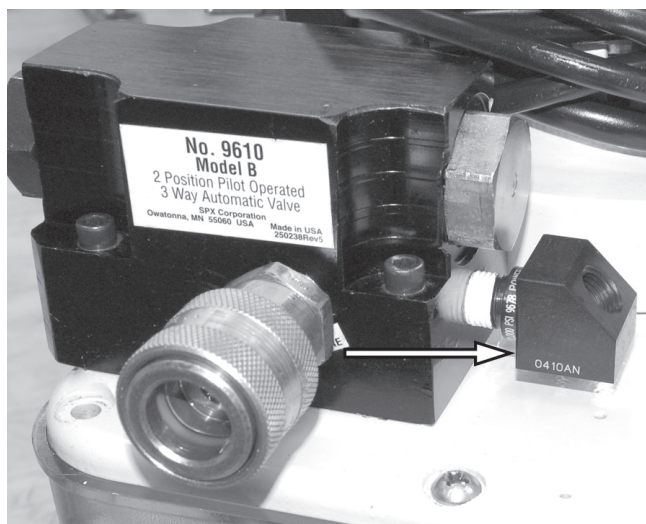

Figure 5. Elbow Installation

4. Refer to Figure 6. Install the pressure gauge.

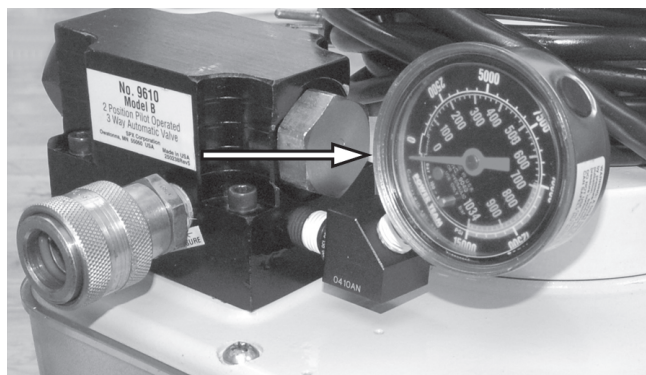

Figure 6. Pressure Gauge Installation

Operating Instructions

Bleeding Air from the System

1. Cycle the hydraulic system until operation is smooth and consistent.
2. Check the pump reservoir level. Add Power Team hydraulic fluid as needed.

Electric Motor Control Operation

1. Connect the power cord to an appropriate power source.
2. Place the motor control switch in the ON position or the REMOTE position, if applicable.
3. Depending on system requirements:

Refer to Figure 7. This remote will start and run the pump motor as long as the button is pressed. Switch will automatically return to OFF position when button is released and pump motor will turn off.



Figure 7. Momentary ON-OFF Push Button Remote Motor Control

Refer to Figure 8. This remote will start and run the pump motor as long as the button is held in the ON position. Switch will automatically return to OFF position when button is released and pump motor will turn off. Generally used with 2-Way, 2-Position valves.



Figure 8. Momentary ON-OFF Remote

Refer to Figure 9. This remote will start and run the pump motor to advance or retract of the cylinder when released it allows the pressure to be held.

4. Press the rocker switch toward the Advance side of the switch and hold to extend the cylinder.
5. Press the rocker switch toward the Retract side of the switch and hold to retract the cylinder.
6. Release the rocker switch and the pump will stop but the system will hold. Generally used on 4-Way-2-Position valves.



Figure 9. Advance-Hold-Retract Remote

Pressure Regulating Controls

To ensure accuracy and low pressure differential (approx. 20 Bar 300 PSI) throughout the pressure range (69-690 Bar (1,000-10,000 PSI) depending on the pump model), the pressure switch should be used with the pressure regulating valve. The pressure switch must be set at a pressure lower than the pressure regulating valve to work correctly.

- The pressure regulating valve can be adjusted to bypass fluid at a given pressure setting while the pump continues to run.
- The pressure switch can be adjusted to stop the pump at a given pressure setting.

Adjusting The Pressure Regulating Valve (if equipped). All others are factory preset.

Note: For easy adjustment of the pressure regulating valve, always adjust the pressure by increasing to the desired pressure setting.

1. Loosen the locknut on the pressure regulating valve.
2. Use a screwdriver to back out the adjusting screw a few turns in a counterclockwise direction. This decreases the setting to a lower-than-desired pressure.
3. The pump must be completely connected. Set the motor control toggle switch on RUN, and push the START button.
4. With the screwdriver, slowly turn the adjusting screw in a clockwise direction. This gradually increases the pressure setting. When the desired pressure is reached, lock the adjusting screw in position by tightening the locknut.

Notes:

- *The pressure range is from 69-690 Bar (1,000-10,000 PSI), depending on the pump model.*
- *The pressure switch must be set at a higher pressure than working range to prevent shut down during adjustment. It is also possible to bypass the pressure switch contacts by holding the start switch or remote control switch so the motor runs continuously.*

Adjusting The Pressure Switch

Generally, the pressure switch should be used with the pressure regulating valve. A pressure switch can be used alone for operating electrical devices such as motors, solenoids, and relays, which are located elsewhere in the circuit.

1. Loosen the locknut on the pressure switch, and turn the adjusting screw in a clockwise direction. This increases the pressure setting to a higher than desired pressure.
2. Adjust the pressure regulating valve to the desired pressure setting by using the procedure previously outlined.
3. With the pump running and bypassing fluid at the desired pressure, slowly turn the pressure switch adjusting screw in a counterclockwise direction, decreasing the pressure switch setting until the pump motor shuts off.
4. Lock the adjusting screw in position by tightening the locknut.
5. Release pressure. Run the pump to check the pressure setting and cut-out of the motor. It may be necessary to make a second adjustment.

Note: When the pressure switch setting is reached, the motor shuts off. However, the "coast" of the motor continues to deliver fluid for a brief period. The pressure regulating valve bypasses this surplus fluid, preventing it from going into the system. As a result, the pressure differential can be held to approximately 20 Bar (300 PSI).

Performance Specifications

The information in the following charts can be used as a basis to determine if the system is performing as expected during operation.

Pump	RPM	Amp Draw at 690 Bar (10,000 PSI) (115V)	Amp Draw at 690 Bar (10,000 PSI) (230V)	dB A at Idle and 690 Bar (10,000 PSI)
PE8	1,725	10	15	67/81
PE17	3,450	10	15	67/81

Table 3. Drive Unit Requirements

Pump	Max. Pressure Output Bar (PSI)	Fluid Delivery** (cu. in./min. @)					
		0 Bar (0 PSI)	7 Bar (100 PSI)	50 Bar (700 PSI)	70 Bar (1,000 PSI)	345 Bar (5,000 PSI)	690 Bar (10,000 PSI)
PE8	690 Bar (10,000 PSI)	145	95	-	-	10	8
PE17	690 Bar (10,000 PSI)	290	190	-	-	20	16

** Typical delivery. Actual flow varies with field conditions.

Table 4. Fluid Pressure Chart

General Maintenance



WARNING:



- **Disconnect the unit from the power supply before performing maintenance or repair procedures.**
- **Repairs and maintenance are to be performed in a dust-free area by a qualified technician.**

System Evaluation

The components of your hydraulic system — cylinders, pumps, hoses, and couplings — all must be:

- Rated for the same maximum operating pressure.
- Correctly connected.
- Compatible with the hydraulic fluid used.

A system that does not meet these requirements can fail, possibly resulting in serious injury. If you are in doubt about the components of your hydraulic system, contact Power Team Technical Support.

Inspection

Keep a dated and signed inspection record of the equipment. An inspection checklist (Form No. 105503) is available on request from your nearest Power Team facility. Before each use, the operator or other designated personnel should visually inspect for the following conditions:

- Cracked or damaged cylinder.
- Excessive wear, bending, damage, or insufficient thread engagement.
- Leaking hydraulic fluid.
- Scored or damaged piston rod.
- Incorrectly functioning or damaged heads and caps.
- Loose bolts or cap screws.
- Damaged or incorrectly assembled accessory equipment.
- Modified, welded, or altered equipment.
- Bent or damaged couplers or port threads.

Periodic cleaning



WARNING: Contamination of the hydraulic fluid could cause the valve to malfunction. Loss of the load or personal injury could result.

Establish a routine to keep the hydraulic system as free from debris as possible.

- Seal unused couplers with dust covers.
- Keep hose connections free of debris. Equipment attached to a cylinder must be kept clean.
- Keep the breather-hole in the filler cap clean and unobstructed.
- Use only Power Team hydraulic fluid. Replace hydraulic fluid as recommended, or sooner if the fluid becomes contaminated. Never exceed 300 hours of use between fluid changes.

Hydraulic Fluid Level

1. Check the fluid level in the reservoir after each 10 hours of use. The fluid level should be 1.3–3.8 cm (0.5–1.5 in.) from the top of the fill hole when all cylinders are retracted.
2. Drain, flush, and refill the reservoir with an approved Power Team hydraulic fluid after every 300 hours of use. The frequency of fluid changes depends upon general working conditions, severity of

General Maintenance continued

use, the overall cleanliness and care given to the pump. Fluid should be changed more frequently when the system is not operated regularly indoors.

Draining And Flushing The Reservoir

IMPORTANT: Clean the pump exterior before the pump interior is removed from the reservoir.

1. Remove the ten screws that fasten the motor and pump assembly to the reservoir.

IMPORTANT: Do not damage the gasket or bump the filter or pressure regulating valves when lifting the pump and motor off the reservoir. See Figure 10.

2. Drain fluid and clean the inside of the reservoir. Fill with a suitable nonflammable flushing fluid. Rinse the filter clean.
3. Place the pump and motor assembly back onto the reservoir and secure with four corner screws.

IMPORTANT: Connect a hose to the advance/retract port of the pump manifold. Place the other end of the hose into the fluid filler plug hole.

4. Run the pump for several minutes. Then disconnect the motor and pump assembly, and drain and clean the inside of the pump reservoir.
5. Fill the reservoir to 1.3–3.8 cm (0.5–1.5 in.) below the cover plate with an approved, high-grade hydraulic fluid. Place the pump and motor assembly (with gasket) onto the reservoir. Thread in ten screws and tighten securely and evenly.

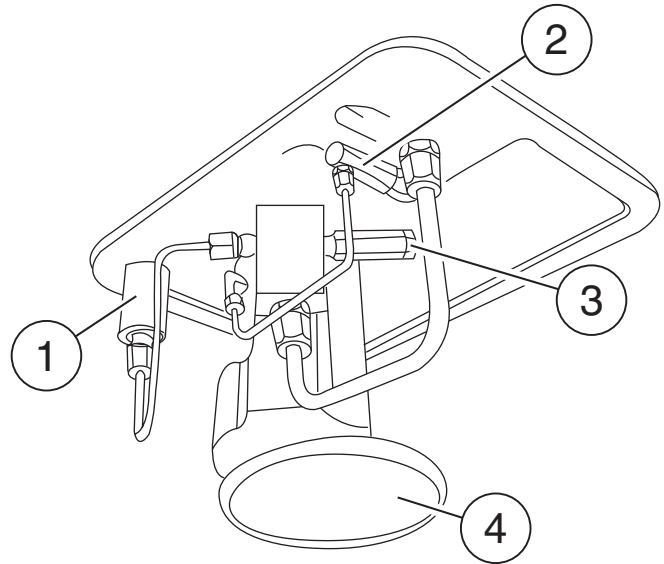

Item	Description
1	Pressure Regulating Valve
2	Accumulator (not used on all models)
3	High Pressure Relief Valve
4	Filter

Figure 10. Pump Assembly

Adding Hydraulic Fluid To The Reservoir

1. Retract the cylinder(s) devices.
2. Disconnect the power supply.
3. Clean the entire area around the filler plug.
4. Remove the filler plug, and install a clean funnel with a filter.
5. Use only Power Team hydraulic fluid rated at AW 46 47 cSt @ 38°C (215 SUS @ 100°F). If low temperature requirements are needed, use hydraulic fluid 5.1 cSt @ 100°C (451 cSt @ -40°C).

Sound Reduction - Electrically Powered Motor

The electrically powered hydraulic pump operates in the 67–81 dBA range. If further sound reduction is desired, any of the following options will help reduce the sound level.

1. Install a pressure switch to automatically shut off the motor when maximum pressure is reached (holding cycle).
2. Contact Power Team Hydraulic Technology technical support for products more suitable to your application.

Hose Connections



CAUTION: To prevent personal injury from leaking hydraulic fluid, seal all hydraulic connections with a high-quality, non-hardening, pipe thread sealant.



IMPORTANT: Sealant tape or non-hardening sealer tape can be used to seal hydraulic connections if only one layer of tape is used. Apply tape carefully, two threads back, to prevent it from being pinched by the coupler and broken off inside the system. Loose pieces of sealant could travel through the system and obstruct the flow of fluid or cause jamming of precision-fit parts.

Storage

Store the unit in a dry, well-protected area where it will not be exposed to corrosive vapors, dust, or other harmful elements. If a unit has been stored for an extended period of time, it must be thoroughly inspected before it is used.

Checking Brushes on Universal Motors

To help prevent premature failure of the armature, check the brushes periodically:

1. Remove the metal brush cover plates.
2. Remove the brush holder caps and brush assemblies.
3. The brush assemblies must be replaced if they are 4.5mm (1/8") long or less. See Figure 11.
4. Install brush assemblies, brush holder caps, and metal brush cover plates.

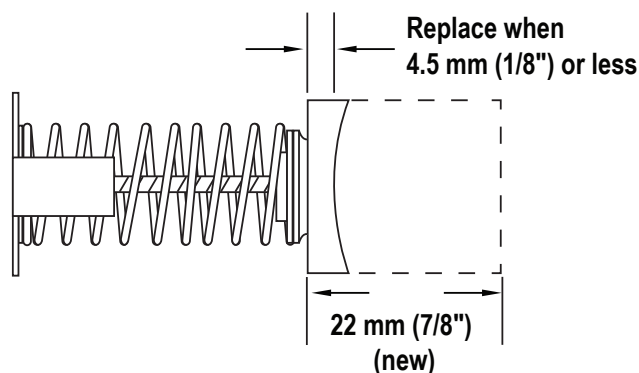

Figure 11. Brush Inspection

Troubleshooting Guide



WARNING:

- Repair work or troubleshooting must be performed by qualified personnel who are familiar with this equipment.
- Disconnect the power supply before removing the electrical cover. Electrical work should be performed by a qualified electrician.
- Check for system leaks by using a hand pump to apply pressure to the suspect area. Watch for leaking fluid and follow it back to its source. Never use your hand or other body parts to check for a possible leak.



Notes:

- For a detailed parts list or to locate a Power Team Authorized Hydraulic Service Center, contact your nearest Power Team facility.
- Plug the outlet ports of the pump when checking for leakage to determine if the leakage is in the pump, in the cylinder, or in the tool.

Problem	Cause	Solution
Electric motor does not run.	1. Unit is not plugged in.	1. Plug in unit.
	2. No voltage supply.	2. Check line voltage.
	3. Broken lead wire or defective power cord plug.	3. Replace defective parts.
	4. Defective motor.	4. Replace or repair motor.
Pump is not delivering hydraulic fluid or delivers only enough hydraulic fluid to advance cylinder(s) partially or erratically.	1. Hydraulic fluid level too low.	1. Fill reservoir to 1-1/2" below the cover plate, maximum.
	2. Air in system.	2. Bleed the system.
	3. Debris is in pump or filter is plugged.	3. Pump filter should be cleaned and, if necessary, pump should be dismantled and all parts inspected and cleaned.
	4. Cold hydraulic fluid or hydraulic fluid is too heavy (hydraulic fluid is of a higher viscosity than necessary).	4. Change to lighter hydraulic fluid.
	5. Relief valve or low pressure unloading valve out of adjustment.	5. Readjust as needed.
	6. Sheared drive shaft key(s).	6. Replace.
	7. Motor rotating in wrong direction.	7. Reverse rotation.

Troubleshooting Guide continued

Problem	Cause	Solution
Pump will not build full pressure.	1. Faulty pressure gauge.	<i>1. Calibrate gauge.</i>
	2. Check for external leakage.	<i>2. Seal any faulty pipe fittings with pipe sealant.</i>
	3. Inspect the pump for internal leakage.	<i>3. Same procedure as above but for leaks around the entire inner mechanism. If there are no visible leaks the low-to-high pressure ball check may be leaking. Remove all parts. Inspect the check body for any damage to the seat areas. Clean and reseal if necessary. Inspect the ball for damages and replace if necessary, then reassemble.</i>
	4. Sheared key(s).	<i>4. Replace.</i>
	5. High pressure pump inlet or outlet ball checks in the pump are leaking.	<i>5. Reseat or replace valve head.</i>
Automatic valve will not build full pressure	1. Unloading pressure is too low.	<i>1. Increase unloading pressure per chart, sheet 3 of 4.</i>
	2. Defective or oversize seat on automatic valve.	<i>2. Replace ball and seat.</i>
Electric motor cuts out.	1. Extension cord is too long and/or not of sufficient gauge.	<i>1. Replace.</i>
	2. Faulty motor.	<i>2. Replace and repair.</i>
	3. Overheated motor can trip circuit breaker in shop power panel.	<i>3. Allow motor to cool, reset circuit breaker located in shop power panel.</i>
Foaming hydraulic fluid.	1. Hydraulic fluid being splashed by counter weight.	<i>1. Lower hydraulic fluid level to approximately 38 mm (1.5 inches) below the cover plate.</i>
Cylinder(s) will not retract.	1. Check the system pressure; if the pressure is zero, the control valve is releasing pressure and the problem may be in the cylinder(s), mechanical linkage connected to cylinder(s), or quick-disconnect couplings.	<i>1. Check the cylinders for broken return springs and check couplers to ensure that they are completely coupled. Occasionally couplers have to be replaced because one check does not stay open in the coupled position.</i>
	2. Inadequate air pressure (air motor only).	<i>2. Increase air pressure.</i>
Pump delivers excess hydraulic fluid pressure.	1. Pressure gauge is not accurate.	<i>1. Calibrate gauge.</i>
	2. Relief valve not properly set.	<i>2. Reset the relief valve.</i>

Troubleshooting Guide continued

Problem	Cause	Solution
Automatic valve will not release pressure.	1. Sticking piston.	<i>1. Remove, clean and polish.</i>
	2. High pressure hydraulic fluid is leaking past the low-to-high pressure check. This hydraulic fluid leaks back to the piston in the automatic valve, keeping the piston closed.	<i>2. Seat the ball check. Inspect and replace any faulty components.</i>

Power Team Facilities



UNITED
STATES

SPX Hydraulic Technologies
5885 11th Street
Rockford, IL 61109-3699
USA
Telephone: 1-815-874-5556
FAX: 1-815-874-7853

Cust. Service/Order Entry
Tel: 1-800-541-1418
FAX: 1-800-288-7031
E-mail:
info@powerteam.com

Technical Services
Tel: 1-800-477-8326
FAX: 1-800-765-8326

CHINA

No. 1568 Hua Shan Road
International Park Center
Shanghai 200052, China
Tel: 86 (21) 2208-5888
FAX: 86 (21) 2208-5682
E-mail
infochina@powerteam.com

FAR EAST

7 Gul Circle
Singapore 629563
Singapore
Tel: (65) 6265-3343
FAX: (65) 6265-6646
E-mail:
infoasia@powerteam.com

EUROPE

Albert Thijsstraat 12
6471 WX Eygelshoven
The Netherlands
Tel: 31 (45) 5678877
FAX: 31 (45) 5678878
E-mail
infoeurope@powerteam.com

For more information, Internet address: <http://www.powerteam.com>

Operating Instructions for:

110-000051-1	PE17 Series	PE192
110-000051-3	PE30-ATCO	PE194
61253	PE30-MAST	PE302-MAST
61463-CL	PE32-ATCO	PE322-MAST
65703-CJJ	PE32-MAST	
99150-B	PE172-CCLUK	
HE172	PE172-FS	
HE174	PE172A-	
PA172	OWENS	
PA174	PE172S-KJ	

TWO STAGE HYDRAULIC PUMP

NOTE:

- Inspect the pump upon arrival.
- Read and carefully follow these instructions. Most problems with new equipment are caused by improper operation or installation.

IMPORTANT: Included in the literature bag are four (4) Self-tapping Screws (#209799). These screws are specifically required for attaching the plastic reservoir to the press or work station on certain units.

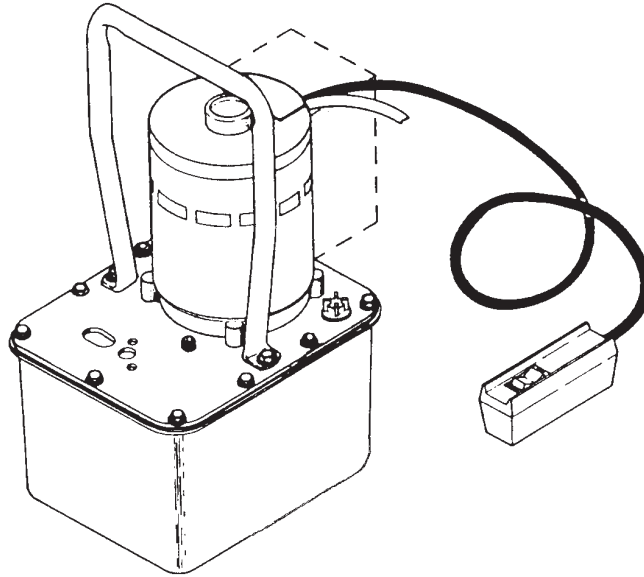

NOTE: These instructions cover several standard pumps. Some special units may appear different or have different specifications. Direct any questions to an appropriate Authorized Service Center or Technical Services Department. An electric model is shown in this figure.

SAFETY PRECAUTIONS



WARNING

- All WARNING statements must be carefully observed to prevent personal injury.

General Operation

- Before operation the pump, all hose connections must be tightened with proper tools. Do not overtighten. Connections need only be tightened securely and leak-free. Overtightening may cause premature thread failure or may cause high pressure fittings to split at pressures lower than their rated capacities.
- Should a hydraulic hose ever rupture, burst, or need to be disconnected, immediately shut off the pump and shift the control valve twice to release all pressure. Never attempt to grasp a leaking hose under pressure with your hands. The force of escaping hydraulic fluid could cause serious injury.
- Do not subject the hose to potential hazard such as fire, extreme heat or cold, sharp surfaces, or heavy impact. Do not allow the hose to kink, twist, curl, or bend so tightly that the oil flow within the hose is blocked or reduced. Periodically inspect the hose for wear because any of these conditions can damage the hose and possibly result in personal injury.
- Do not use the hose to move attached equipment. Stress may damage the hose and possibly cause personal injury.
- Hose material and coupler seals must be compatible with the hydraulic fluid used. Hoses also must not come in contact with corrosive materials such as creosote-impregnated objects and some paints. Consult the manufacturer before painting a hose. Never paint the couplers. Hose deterioration due to corrosive materials may result in personal injury.

Pump

- Do not exceed the PSI hydraulic pressure rating noted on the pump name plate or tamper with the internal high pressure relief valve. Creating pressure beyond rated capacities may result in personal injury.
- Before replenishing the oil level, retract the system to prevent overfilling the pump reservoir. An overfill may cause personal injury due to excess reservoir pressure created when cylinders are retracted.

Safety Precautions (Continued)

Cylinder

- Do not exceed rated capacities of the cylinders. Excess pressure may result in personal injury.
- Do not set poorly-balanced or off-center loads on a cylinder. The load may tip and cause personal injury.

Air Supply

- Shut off and disconnect the air supply when the pump is not in use or before breaking any connection in the system.

Electrical Supply

- Do not use an ungrounded (two-prong) extension cord.
- Avoid conditions which could create an electrical hazard.
- If the power cord is damaged or wiring exposed, replace or repair immediately.
- Check the voltage rating on the pump motor name plate to be certain the outlet you are using is of the proper voltage.
- Correct voltage is required for pump to operate properly.
- Low voltage may cause the following: overheated motor; motor fails to start under load; motor surging when trying to start; motor stalls before maximum pressure is reached.
- Always check the voltage at the motor with the pump running at full pressure.
- Never run the motor on long, light gauge extension cords.
- Low voltage = 10% less than name plate voltage.
- Line voltage for all permanent magnet motors (PE19 series) must not exceed 120 volts AC.



Electric Motor

SET-UP AND OPERATION

WARNING: To help avoid possible personal injury,

- Any electrical work must be done by a qualified electrician.
- Disconnect the power supply before removing the motor casing cover or performing repairs or maintenance.
- Changing the voltage on this unit is an involved, and if improperly performed, hazardous procedure. Consult the manufacturer for specific information before attempting any rewiring.

Hydraulic Set-up

1. Clean the areas around the oil ports of the pump and hydraulic cylinders.
2. Inspect the threads and fittings for signs of wear or damage and replace as needed. Clean all hose ends, couplers, and union ends.
3. Remove the plastic thread protectors from the hydraulic outlets. Connect the hose assembly to the valve and couple the hose to the cylinder.
4. Seal all pipe connections with pipe sealant. PTFE tape can be used to seal hydraulic connections provided only one layer of tape is used. Apply the tape carefully to prevent it from being pinched by the coupler and broken off inside the pipe end. Any loose pieces of tape could travel through the system and obstruct the flow of oil or cause jamming of precision-fit parts.

Air Motor Set-up

Remove the thread protector from the air inlet and install the air supply fittings (not included) as shown at right. Air supply must be minimum 20 CFM and 80 PSI, with 100 PSI maximum.

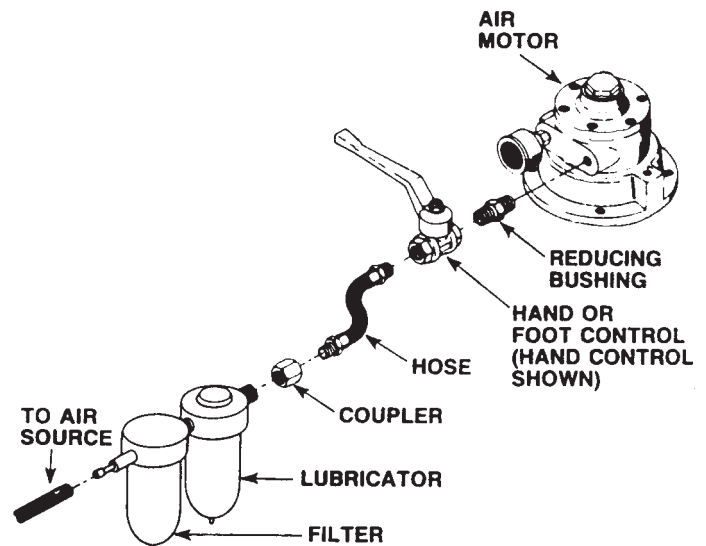

**RECOMMENDED
AIR LINE HOOK-UP**

Filling the Reservoir

NOTE: The pump is shipped without oil in the reservoir. Oil is included in a separate container.

1. Thoroughly clean the area around the filler cap with a clean cloth to prevent contamination of the oil by foreign particles.
2. Remove the filler cap and insert a clean funnel with filter. Reservoir may be filled to within 1" of the top cover with all cylinders retracted. Replace filler cap and check to see that the breather-hole in the cap is open. **Note: If oil foaming becomes a problem, reduce the oil level to 2" below the cover plate.**

Valve Operation

2-Position, 2-Way Manual Valves used with Single-acting Cylinders

1. To build pressure, turn the valve control handle counterclockwise (CCW).
2. Start the pump by pressing the remote motor control ON/OFF switch. **NOTE: Oil advances the cylinder when the unit is activated.**
3. When the cylinder has advanced to the desired position, release the remote motor control ON/OFF switch.
4. To retract the cylinder, turn the valve control clockwise (CW).

NOTE: The valve works the same as the manifold if the pump is operated with the valve in the RETURN position. In this position, the cylinder advances when the pump is running and retracts when the motor is stopped.

When the valve is in the HOLD position, the cylinder advances when the pump is running and holds when the motor is stopped. The cylinder can be retracted by moving the valve to the RETURN position.

Manifold Assembly used with Single-acting Cylinders or Remote Valves

1. Start the pump by pressing the remote motor control ON/OFF switch. **NOTE: Oil advances the cylinder when the unit is activated.**
2. When the cylinder has advanced to the desired position, release the remote motor control ON/OFF switch. The cylinder will retract.

Tandem Center 4-Way Control Valve used with Double-acting Cylinders

1. Place the valve control lever in the NEUTRAL or hold position.
2. Start the pump by pressing the remote motor control ON/OFF switch.
3. Advance the cylinder by shifting the valve control lever to the ADVANCE position.
4. When the cylinder has advanced to the desired position, release the remote motor control ON/OFF switch.

NOTE: The cylinder momentarily loses pressure during the shifting process.

5. Retract the cylinder by shifting the valve control lever to the RETRACT position.

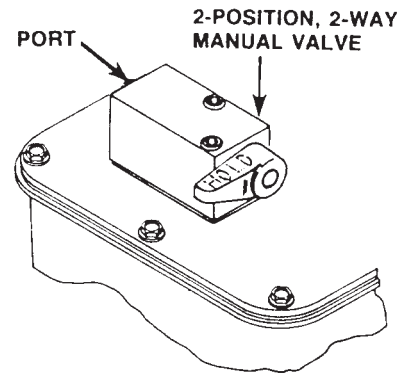

FIGURE 1

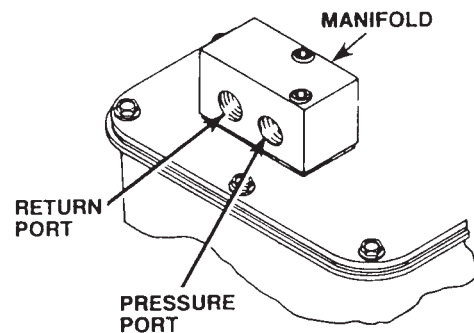

FIGURE 2

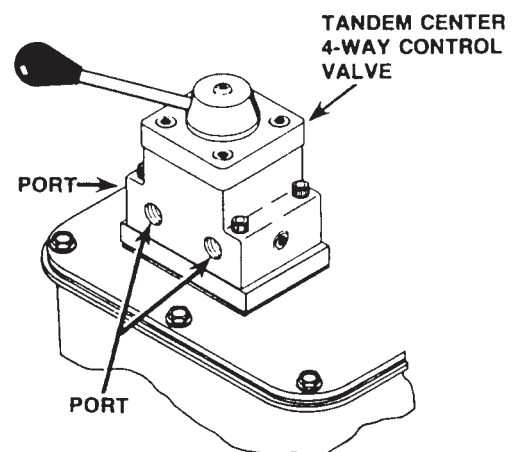

FIGURE 3



PREVENTIVE MAINTENANCE

WARNING: To help avoid possible personal injury,

- Disconnect the pump from the poser supply before performing maintenance or repair procedures.
- Repairs and maintenance should be performed in a dust-free area by a qualified technician.

Bleeding Air from the System

Air can accumulate in the hydraulic system if the reservoir oil level has been permitted to get too low. This air causes the cylinder to respond in an unstable or slow manner. To remove the air:

1. Position hydraulic cylinder(s) on their sides with the couplers located upward and at a lower level than the pump.
2. Remove any load from the cylinder(s), and cycle the hydraulic system through several cycles (fully extend and retract the cylinders).

Hydraulic Fluid Level

1. Check the oil level in the reservoir after each 10 hours of use. Due to the very limited amount of oil required by the typical hydraulic cylinder(s) used with this pump, the oil level is considered adequate when the reservoir is partially full. Maximum capacity is when the oil is 1-1/2" below the cover plate with all cylinders retracted.
2. When adding oil, use an approved, high-grade hydraulic oil (215 SSU @ 100°F). Retract the cylinders and disconnect the power supply. Clean the area around the filler plug, remove the plug, and insert a clean funnel with filter.
3. The frequency of oil changes will depend upon the general working conditions, severity of use, and overall cleanliness and care given the pump. Three hundred hours of use under general shop conditions is considered a standard change interval. Drain, flush, and refill the reservoir with an approved, high-grade hydraulic oil (215 SSU @ 100°F).

Lubrication (Air Driven Motor only)

If the pump is operated on a continuous duty cycle or at maximum speeds for extended periods, an automatic air line oiler should be installed in the air inlet line as close to the pumping unit as possible. Set the unit to feed 1 drop of oil per minute (one drop for every 50-75 CFM of air) into the system, or refer to the air pump manufacturer's instructions. Use SAE #10 oil.

Draining and Flushing the Reservoir

IMPORTANT: Clean the pump exterior before the pump interior is removed from the reservoir.

1. Remove the ten screws that fasten the motor and pump assembly to the reservoir.

IMPORTANT: Do not damage the gasket or bump the filter or pressure regulating valves when lifting the pump and motor off the reservoir. See Figures 4 & 5.

2. Drain oil and clean the inside of the reservoir. Fill with a suitable nonflammable flushing oil. Rinse the filter clean.
3. Place the pump and motor assembly back onto the reservoir and secure with four of the ten screws. Assemble the screws in opposite corners of the housing.

IMPORTANT: Connect a hose to the advance/retract port of the pump manifold. Place the other end of the hose into the oil filler plug hole.

4. Run the pump for several minutes. Then disconnect the motor and pump assembly, and drain and clean the inside of the pump reservoir.
5. Fill the reservoir to 1-1/2" below the cover plate with an approved, high-grade hydraulic oil. Place the pump and motor assembly (with gasket) onto the reservoir. Thread in ten screws and tighten securely and evenly.

Maintenance and Cleaning

1. Keep the pump's outer surface as free from dirt as possible.
2. Seal all unused couplers with thread protectors.
3. Keep all hose connections free of dirt and grime.
4. The breather-hole in the filler cap must be clean and unobstructed at all times.
5. Equipment connected to the pump must be kept clean.
6. Use only an approved, high-grade hydraulic oil in this pump. Change as recommended (approx. every 300 hours).
7. Periodically lubricate the electric pump motor.

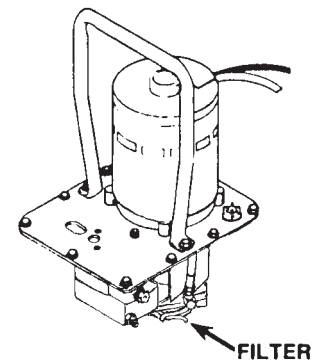

FIGURE 4

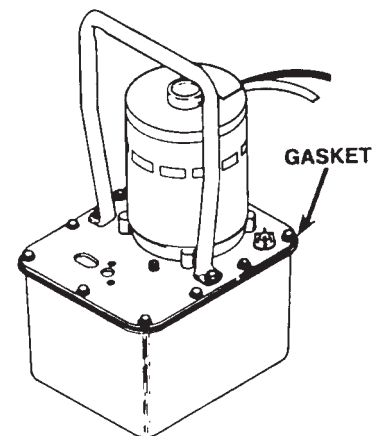

FIGURE 5



TROUBLE-SHOOTING GUIDE

WARNING: To help avoid possible personal injury,

- All repair work or trouble-shooting must be done by qualified personnel familiar with this equipment.
- Use the proper gauges and equipment when trouble-shooting.

NOTE:

- Depending on the type of pump, it is often best to check for leaks by using a hand pump and applying pressure to the suspect area without the motor running. Watch for leaking oil and follow it back to its source.
- Plug the outlet ports of the pump when checking for leakage to determine if the leakage is in the pump or if it is in the cylinder or tool.
- Refer to your pumps parts list and the following hydraulic schematic when using this trouble-shooting guide.

HYDRAULIC SCHEMATIC

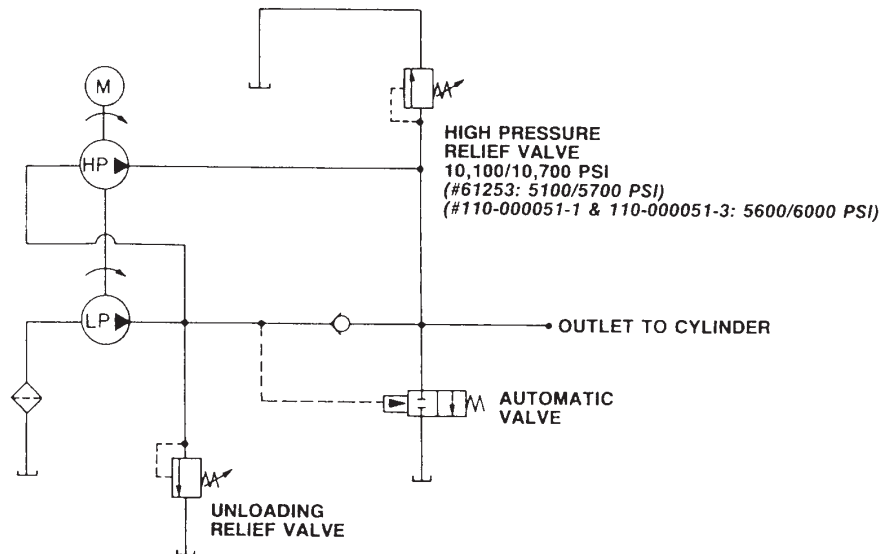

Unloading valve setting (measured at low pressure pump hose)	230/290 PSI	260/320 PSI	310/370 PSI
PUMP PART NUMBER	110-000051-3 110-000051-1 99150-B HE172 HE174 PE17 SERIES PE172A-OWENS PE172S-KJ PE192 PE192 PE30-MAST PE30-ATCO PE32-MAST PE32-ATCO PE302-MAST PE322-MAST 65703-CJJ 61463-CL PE172-CCLUK	PA172 PA174	61253

PROBLEM	CAUSE	SOLUTION
Motor does not run	<ol style="list-style-type: none"> 1. Unit is not plugged in. 2. No voltage supply. 3. Broken lead wire or defective power cord plug. 4. Defective motor. 	<ol style="list-style-type: none"> 1. Plug in unit. 2. Check line voltage. 3. Replace defective parts. 4. Replace or repair motor.
Pump is not delivering oil or delivers only enough oil to advance cylinder(s) partially or erratically	<ol style="list-style-type: none"> 1. Oil level too low. 2. Air in system. 3. Dirt is in pump or filter is plugged. 4. Cold oil or oil is too heavy (hydraulic oil is of a higher viscosity than necessary). 5. Relief valve or low pressure unloading valve out of adjustment. 6. Sheared drive shaft key(s). 7. Motor rotating in wrong direction. 	<ol style="list-style-type: none"> 1. Fill reservoir to 1-1/2" below the cover plate, maximum. 2. Bleed the system. 3. Pump filter should be cleaned and, if necessary, pump should be dismantled and all parts inspected and cleaned. 4. Change to lighter oil. 5. Readjust as needed. 6. Replace. 7. Reverse rotation.
Pump will not build full pressure	<ol style="list-style-type: none"> 1. Faulty pressure gauge. 2. Check for external leakage. 3. Inspect the pump for internal leakage. 4. Sheared key(s). 5. High pressure pump inlet or outlet ball checks in the pump are leaking. 6. Inadequate air pressure (air motor only). 	<ol style="list-style-type: none"> 1. Calibrate gauge. 2. Seal any faulty pipe fittings with pipe sealant. 3. Same procedure as above but for leaks around the entire inner mechanism. If there are no visible leaks the low-to-high pressure ball check may be leaking. Remove all parts. Inspect the check body for any damage to the seat areas. Clean and reseat if necessary. Inspect the ball for damages and replace if necessary, then reassemble. 4. Replace. 5. Reseat or replace valve head. 6. Increase air pressure.
Automatic valve will not build full pressure	<ol style="list-style-type: none"> 1. Unloading pressure is too low. 2. Defective or oversize seat on automatic valve. 	<ol style="list-style-type: none"> 1. Increase unloading pressure per chart, sheet 3 of 4. 2. Replace ball and seat.
Electric motor cuts out	<ol style="list-style-type: none"> 1. Extension cord is too long and/or not of sufficient gauge. 2. Faulty motor. 3. Overheated motor can trip circuit breaker in shop power panel. 	<ol style="list-style-type: none"> 1. Replace. 2. Replace and repair. 3. Allow motor to cool, reset circuit breaker located in shop power panel.

PROBLEM	CAUSE	SOLUTION
Foaming oil	<ol style="list-style-type: none"> 1. Oil being splashed by counter weight. 	<ol style="list-style-type: none"> 1. Lower oil level to approximately 1-1/2" below the cover plate.
Cylinder(s) will not retract	<ol style="list-style-type: none"> 1. Check the system pressure; if the pressure is zero, the control valve is releasing pressure and the problem may be in the cylinder(s), mechanical linkage connected to cylinder(s), or quick-disconnect couplings. 2. Inadequate air pressure (air motor only). 	<ol style="list-style-type: none"> 1. Check the cylinders for broken return springs and check couplers to ensure that they are completely coupled. Occasionally couplers have to be replaced because one check does not stay open in the coupled position. 2. Increase air pressure.
Pump delivers excess oil pressure	<ol style="list-style-type: none"> 1. Pressure gauge is not accurate. 2. Relief valve not properly set. 	<ol style="list-style-type: none"> 1. Calibrate gauge. 2. Reset the relief valve.
Automatic vale will not release pressure	<ol style="list-style-type: none"> 1. Sticking piston. 2. High pressure oil is leaking past the low-to-high pressure check. This oil leaks back to the piston in the automatic valve, keeping the piston closed. 	<ol style="list-style-type: none"> 1. Remove, clean and polish. 2. Seat the ball check. Inspect and replace any faulty components.

ELECTRICAL SCHEMATICS



WARNING

To help avoid personal injury, all electrical work must be done by a qualified electrician.

North American & International Color Codes

Conductors	North American	International
Line	Black	Brown
Neutral	White	Blue
Ground	Green	Green/Yellow

110 V., 60 Hz./115 V., 50 Hz.

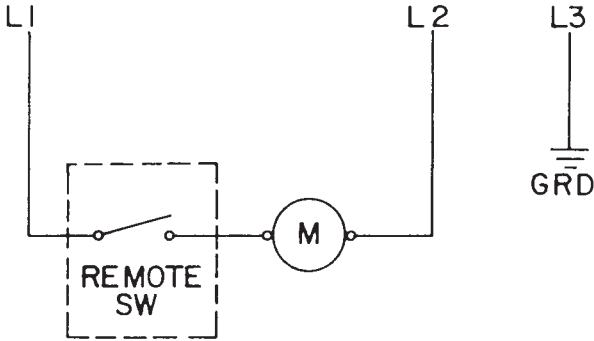

115 V., 50/60 Hz.
for PE192 & PE194

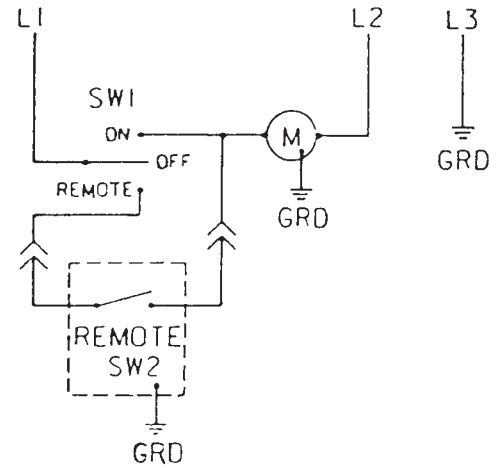

220 V., 50 HZ.

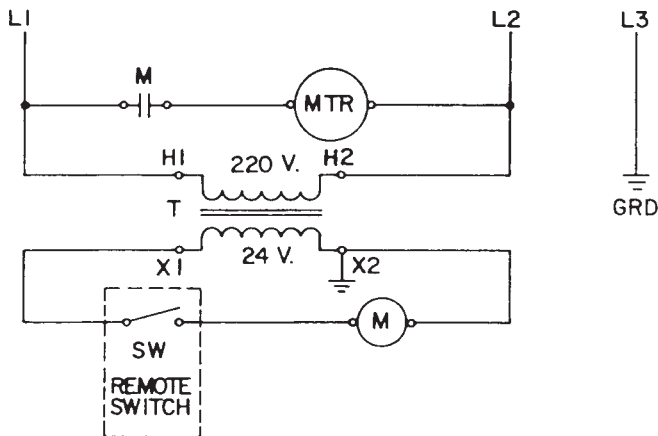

Operating Instructions for:



Electric Motor Powered Pumps
Gas Engine Powered Pumps
Rotary Air Motor Powered Pumps

(As listed in EC Declaration)

HYDRAULIC PUMP

Max. Capacity: See Pump Data Plate

Pump	kw	dB(A) at Idle and 700 Bar
PE8 Series	.37	67/81
PE17 Series	.37	67/81
PA17 Series	1.12	85/90
PE30 Series	.74	87/82
PG30 Series	1.49	84/96
PE46 Series	1.12	77/81
PA46 Series	2.24	85/90
PE55 Series	.84	87/86
PA55 Series	2.24	87/88
PG55 Series	2.98	75/87
PR10 Series	.19	65/72
PG18 Series	1.86	81/96
PG120 Series	4.1	85/95
PQ120 Series	2.24	73/78
PG400 Series	14.9	N/A
66262	2.24	N/A

Definition: A hydraulic pump delivers hydraulic fluid under pressure through the use of compressed air, an electric motor, or a gas engine as a power source.

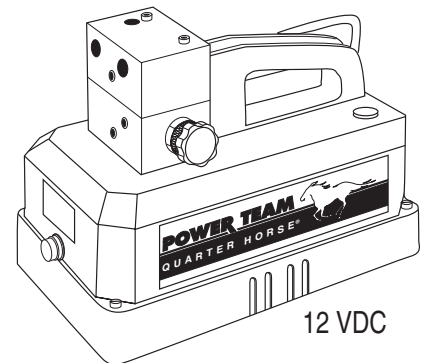
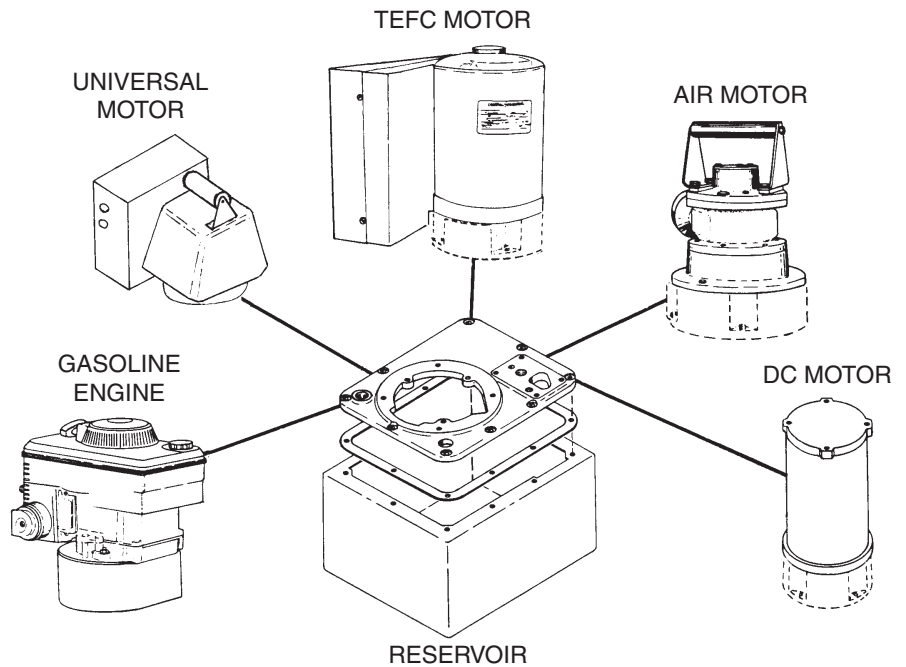

NOTE:

- For a detailed parts list or to locate a Power Team Authorized Hydraulic Service Center, contact your nearest Power Team facility. A list of all Power Team facilities is located at the end of this document.
- Carefully inspect the pump upon arrival. The carrier, not the manufacturer, is responsible for any damage resulting from shipment.
- The customer can choose from a variety of motors, controls, reservoirs, and other options. These instructions will include directions for options that your particular pump may not have.
- Do not change motors without consulting the pump manufacturer's Technical Services Department.

SAFETY DEFINITIONS

Safety symbols are used to identify any action or lack of action that can cause personal injury. Your reading and understanding of these safety symbols is very important.

 **DANGER** - Danger is used only when your action or lack of action will cause serious human injury or death.

 **WARNING** - Warning is used to describe any action or lack of action where a serious injury can occur.

 **DANGEROUS VOLTAGE** - Dangerous voltage is used to describe any action or lack of action that could cause serious personal injury or death from high voltage electricity.

IMPORTANT - Important is used when action or lack of action can cause equipment failure, either immediate or over a long period of time.

SAFETY PRECAUTIONS



These instructions are intended for end-user application needs. Many problems with new equipment are caused by improper operation or installation. For a detailed parts list or to locate a Power Team Authorized Hydraulic Service Center contact your nearest Power Team facility. A list of all Power Team facilities is located at the end of this document.

 **WARNING:** It is the operator's responsibility to read and understand the following safety statements,

- Only qualified operators should install, operate, adjust, maintain, clean, repair, or transport this machinery.
- These components are designed for general use in normal environments. These components are not specifically designed for lifting and moving people, agri-food machinery, certain types of mobile machinery or special work environments such as: explosive, flammable or corrosive. Only the user can decide the suitability of this machinery in these conditions or extreme environments. Power Team will supply information necessary to help make these decisions.

 **WARNING:** To help prevent personal injury,

GENERAL

-  Always wear eye protection whenever operating hydraulic equipment.
-  Always wear hearing protection as required. Refer to the sound level (dB[A]) chart.
- Operation, repair, or maintenance of hydraulic equipment should be performed by a qualified person who understands the proper function of hydraulic equipment per local directives and standards.
- Hydraulic equipment must be assembled correctly and then checked for proper function before use. Use hydraulic components of the same hydraulic pressure ratings. An appropriate hydraulic pressure gauge is recommended to monitor pressure.
-  Never place your hands or other body parts near a hydraulic fluid leak.
Never use your hands or other body parts to check for a possible leak.
High pressure fluid can be injected under your skin causing serious injury and/or infection.

SAFETY PRECAUTIONS (GENERAL) CONTINUED -

- High pressure fluid is present throughout a hydraulic system. Always use caution when operating, repairing, or maintaining this equipment. Before beginning any work on any hydraulic system component, stop the equipment, disconnect from its power source, and relieve all pressure in all parts of the system. Do not tamper with the internal hydraulic relief valve settings.
- Avoid exposing hydraulic equipment (especially hoses) to extreme high or low temperatures. Damage to equipment or failure may result and cause loss of control or injury to the operator.
-  Exercise caution to avoid the risk of fire.
- Do not drop any hydraulic system components. Damage to the equipment and/or injury may result.
- Avoid slipping or falling by cleaning up any oil spills.
- Avoid back injury by always lifting equipment carefully.
- It is strongly recommended to view the Power Team Hydraulic Safety video tape before using hydraulic equipment.

POWER SUPPLY**Electric****Electrical Shock or Electrocution**

- Any electrical work must be done and tested by a qualified electrician per local directives and standards.
- Disconnect the pump from the power supply and relieve pressure before removing the motor case cover or performing maintenance or repair.
- Never use an ungrounded power supply with this unit.
- If the power cord is damaged or wiring is exposed, replace or repair immediately.
- Changing the voltage on this unit is an involved, and if improperly performed, hazardous procedure. Consult the manufacturer for specific information before attempting any rewiring.
- All PE55 Series pump motors must be wired for clockwise (CW) rotation when viewed from the lead end (top) of the motor. PE8 Series, PE17 Series, PE30 Series, PR10 Series, and PE46 Series pump motors must be wired for counterclockwise (CCW) rotation when viewed from the lead end (top) of the motor.
- Check the *total* amperage draw for the electrical circuit you will be using. (For example: Do not plug a pump or pumps that may draw 25 amps into a 20 amp fused electrical circuit.)
- Do not attempt to increase the powerline capacity by replacing a fuse with another fuse of higher value. Overheating of the powerline and the possibility of a fire will result.
- To rewire a motor from one voltage to another or when a flow control valve is changed between manual and solenoid, consult the electrical schematic in the pump's parts list.
- Electric pumps should never be exposed to rain or water which could cause personal electrical hazard.
- Avoid conditions which can cause damage to the power cord such as abrasion, crushing, sharp cutting edges, or corrosive environment. Damage to the power cord can cause an electrical hazard.

Gasoline Engine**No Smoking No Open Flame Flammable**

- Read the instruction manual for the gasoline engine before using for correct operating procedure.
- Turn off the engine and relieve pressure when not in use or when working on any part of the system.
- Proper ventilation is critical during refueling.
- Do not allow fuel to splash on the engine when refueling.
- Do not add fuel when the engine is running or hot.

SAFETY PRECAUTIONS (POWER SUPPLY) CONTINUED -

Air Driven Motor

- A quick disconnect must be installed in the air line to the pump.
- Disconnect air supply and relieve pressure when pump is not in use or when breaking any connection in the hydraulic system.
- Control circuit must comply with local directives and standards.

HYDRAULIC HOSES AND FLUID TRANSMISSION LINES

- Avoid straight line tubing connections in short runs. Straight line runs do not provide for expansion and contraction due to pressure and/or temperature changes. See diagrams in “Set-up Instructions” section of this form.
- Eliminate stress in the tube lines. Long tubing runs should be supported by brackets or clips. Tubes through bulkheads must have bulkhead fittings. This makes easy removal possible and helps support the tubing.
- Before operating the pump, all hose connections must be tightened with the proper tools. Do not overtighten. Connections should only be tightened securely and leak-free. Overtightening can cause premature thread failure or high pressure fittings to split at pressures lower than their rated capacities.
- Should a hydraulic hose ever rupture, burst, or need to be disconnected, immediately shut off the pump and release all pressure. Never attempt to grasp a leaking pressurized hose with your hands. The force of escaping hydraulic fluid could cause serious injury.
- Do not subject the hose to potential hazard such as fire, sharp surfaces, extreme heat or cold, or heavy impact. Do not allow the hose to kink, twist, curl, crush, cut, or bend so tightly that the fluid flow within the hose is blocked or reduced. Periodically inspect the hose for wear, because any of these conditions can damage the hose and possibly result in personal injury. Never repair with tape.
- Do not use the hose to move attached equipment. Stress can damage the hose and possibly cause personal injury.
- Hose material and coupler seals must be compatible with the hydraulic fluid used. Hoses also must not come in contact with corrosive materials such as creosote-impregnated objects and some paints. Hose deterioration due to corrosive materials can result in personal injury. Consult the manufacturer before painting a hose. Never paint a coupler.

PUMP

- Do not exceed the hydraulic pressure rating noted on the pump nameplate or tamper with the internal high pressure relief valve. Creating pressure beyond rated capacities can result in personal injury.
- Before replenishing the fluid level, retract the system to prevent overfilling the pump reservoir or bladder. An overfill can cause personal injury due to excess reservoir or bladder pressure created when the cylinders are retracted.
- Always shut off the motor or engine and relieve pressure before breaking any connections in the system.
- The motor or engine is the major part of the weight of the pump. Always take this into consideration when lifting or moving the pump.

CYLINDER

- Do not exceed the rated capacities of the cylinders. Excess pressure can result in personal injury.
- Do not set poorly balanced or off-center loads on a cylinder. The load can tip and cause personal injury.
- Read and understand the cylinder operating instructions and warning decals before using the cylinder.



DANGER: A double-acting cylinder or ram must have both hoses and all couplers securely connected to both ports. If one of the two ports is restricted or becomes disconnected, pressure will build and the cylinder, hose or coupler can burst, possibly causing serious injury or death.

HYDRAULIC FLUIDS

- Properly dispose of all fluids, components, and assemblies at the end of their useful life.
- Hydraulic fluid should be compatible with all hydraulic components.

SET-UP INSTRUCTIONS

Filling The Pump Reservoir Or Bladder

NOTE: Most pumps are shipped without hydraulic fluid in the reservoir. Hydraulic fluid may have been shipped with the pump in a separate container. If hydraulic fluid is needed, use 215 SSU @ 100° F (47 cSt @ 38° C) hydraulic fluid. Pumps with a bladder are shipped with hydraulic fluid in the bladder.

1. Clean the area around the filler cap to remove all dust and grit. Any dirt or dust in the hydraulic fluid can damage the polished surfaces and precision-fit components of this pump.
2. Retract all cylinder(s) to their return position.
3. Remove the filler cap and insert a clean funnel with a filter. Fill the reservoir with hydraulic fluid to 1" (25,4 mm) (PE8, PE17 & PE30 series pumps to 1-1/2" [38,1 mm]) from the cover plate. PR10 series pump bladder must be filled completely. Replace the filler cap. **IMPORTANT: For PR10 series pumps, tighten filler cap 1/2 - 1 turn after o-ring contacts sealing surface. Overtightening can cause pump damage on bladder equipped pumps.**

Hydraulic Connections

Remove the thread protectors or dust covers from the hydraulic ports if applicable. Clean the areas around the fluid ports of the pump and cylinder. Inspect all threads and fittings for signs of wear or damage, and replace as needed. Clean all hose ends, couplers and union ends. Connect all hose assemblies to the pump and cylinder. Use an approved, high-grade pipe thread sealant to seal all hydraulic connections. Tighten securely and leak-free but do not overtighten.

Hydraulic lines and fittings can act as restrictors as the cylinder or ram retracts. The restricting or slowing of the fluid flow causes back pressure that slows the cylinder's or ram's return. Return speed also varies because of the application, condition of the cylinder or ram, inside diameter of hose or fitting, length of the hose, and the temperature and viscosity of the hydraulic fluid.

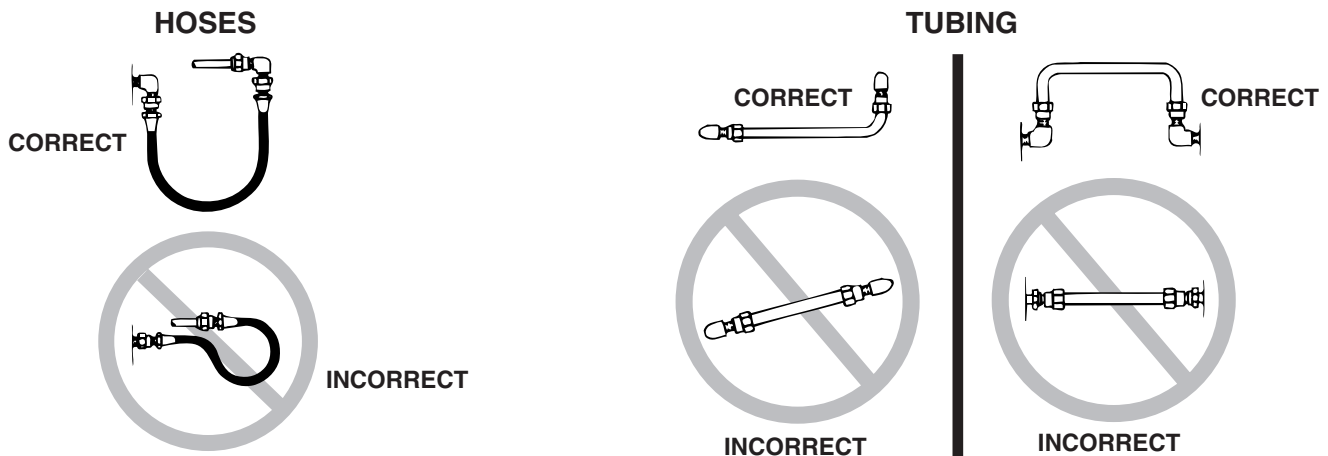

Bleeding The System

After all connections are made, the hydraulic system must be bled of any trapped air. Refer to the diagrams below.

With no load on the system and the pump vented and positioned higher than the cylinder or ram, cycle the system several times. Check the reservoir for possible low fluid level and fill to proper level with approved, compatible hydraulic fluid as necessary (see "Filling The Pump Reservoir Or Bladder" section under Set-up Instructions).

IMPORTANT: Some spring return cylinders or rams have a cavity in the rod which forms an air pocket. This type of cylinder or ram should be bled when positioned upside down or lying on its side with the port facing upward.

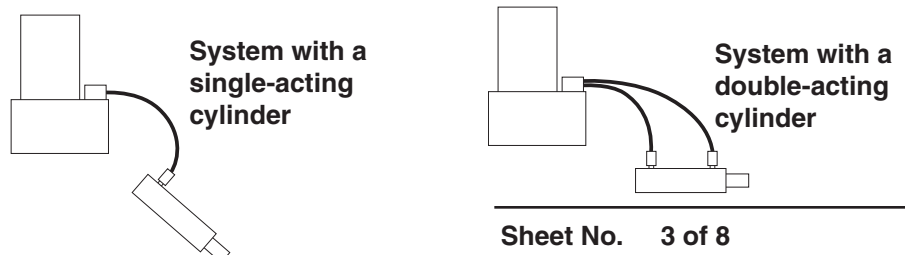

PUMP OPERATION

When operating the pump for the first time:

1. Valve and hose connections must be tight, and the reservoir or bladder must be filled to the proper fluid level. Start the motor.
2. Jog the pump several times to build pressure.
3. Run cylinder out to its full travel several times to eliminate air from the system. For more complete instructions, refer to the section titled "Bleeding The System" under Set-up Instructions.
4. With the cylinder(s) retracted completely, check the fluid level in the reservoir or bladder and add fluid if necessary. Refer to "Filling The Pump Reservoir Or Bladder" under Set-up Instructions.
5. The pump is now ready to be put into regular operation.



DANGER: When lifting or lowering a load, the load must be under operator control at all times and others must be clear of the load. Use blocking and cribbing to guard against a falling load. Do not drop the load. The use of a load lowering or metering valve is recommended in addition to the pump directional control valve.

ELECTRIC PUMP

Universal Motor: The universal motor is wired for 115 or 230 volts, 50/60 cycles according to the customer's request. **This motor cannot be rewired.**

TEFC and DC Motors: See pump data plate for voltage, frequency, current, and power specifications. If rewired, retesting may be required per local directives and standards. PR10 series pump voltage is 12 VDC and is not changeable.

1. Place the valve in neutral position.
2. Plug in the pump.
3. Start the pump and shift as required.
4. Turn the pump off when not in use.

Note: For specific function of your pump see the "Valve Options" section of this form.

IMPORTANT:

- **Correct voltage is required for the pump to operate properly.**
 - **Low voltage may cause: overheated motor; motor fails to start under load; motor surging when trying to start; or motor stalls before maximum pressure is reached.**
 - **Check the voltage rating on the pump motor name plate to be certain the outlet or power source you are using is of the proper voltage.**
 - **Always check the voltage at the motor with the pump running at full pressure.**
- **Never run the motor on long, light gauge extension cords. Refer to the minimum recommended gauge chart below.**

AMPS At Maximum Hyd. Pressure	Electrical Cord Size AWG (mm ²) 3.2 Volt Drop			
	Length of Electrical Cord			
	0-25 ft. (0-8 m)	25-50 ft. (8-15 m)	50-100 ft. (15-30 m)	100-150 ft. (30-46 m)
6	18 (.82)	16 (1.33)	14 (2.09)	12 (3.32)
10	18 (.82)	14 (2.09)	12 (3.32)	10 (5.37)
14	16 (1.33)	12 (3.32)	10 (5.37)	8 (8.37)
18	14 (2.09)	12 (3.32)	8 (8.37)	8 (8.37)
22	14 (2.09)	10 (5.37)	8 (8.37)	6 (13.30)
26	12 (3.32)	10 (5.37)	8 (8.37)	6 (13.30)
30	12 (3.32)	10 (5.37)	6 (13.30)	4 (21.29)

PUMP OPERATION CONTINUED -

GAS PUMP

Gasoline-Powered: Consult the instruction manual for the gasoline engine to determine its specifications.

1. Place the valve in the neutral or hold position.
2. Start the gas engine according to the operating instruction manual provided.
3. When the engine is running properly, shift the valve as necessary.
4. Turn the pump off when not in use.

AIR PUMP

Rotary Air Motor: Remove the thread protectors from the air inlet, and install the air supply fittings (not supplied) as shown in Figure 1. Air supply must be minimum 50 CFM (1,4 M³/min.) and 80 PSI (5,5 BAR), with 100 PSI (7 BAR) maximum.

1. Place the valve in the neutral or hold position.
2. Couple the air pump to the air supply and turn on the supply valve (if provided).
3. Open (or turn on) the air supply control valve at the pump (hold-to-run hand control is provided).
4. Shift the pump as necessary.
5. Turn the pump off when not in use.
6. Use of an air filter/lubricator is recommended.

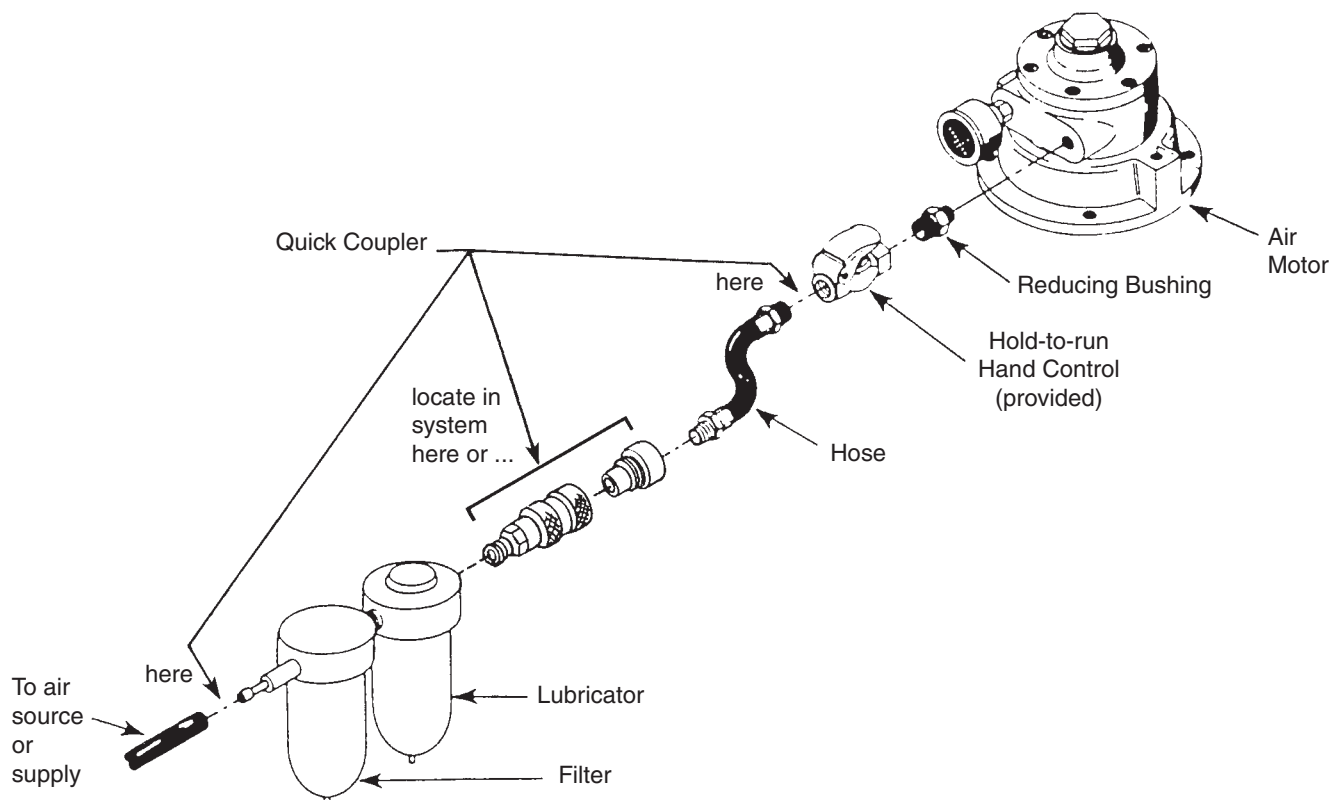

Figure 1
Recommended Air Line Hook-up

DIRECTIONAL CONTROL VALVE OPTIONS

- NOTE:**
- Some valves return fluid to the reservoir or bladder when the pump stops or when the valve is shifted. The correct valve must be used, especially when lifting a load.
 - "Hold-to-run" controls are recommended and must be used with correct valves for certain applications, especially when lifting a load.
 - Not all valves fit on all pumps.

! DANGER: When lifting or lowering a load, the load must be under operator control at all times and others must be clear of the load. Use blocking and cribbing to guard against a falling load. Do not drop the load. The use of a load lowering or metering valve is recommended in addition to the pump directional control valve.

2-Position, 2-Way Manual Valve Used With Single-acting Cylinder

1. To HOLD pressure, turn the valve control handle counterclockwise (CCW).
2. Activate the pump unit to advance the cylinder.
3. When the cylinder has advanced to the desired position, deactivate the switch or remote switch, or turn the pump unit OFF. The cylinder will HOLD pressure.
4. To retract the cylinder, turn the valve control handle clockwise (CW) slowly.

FOR PE17 SERIES (9517)

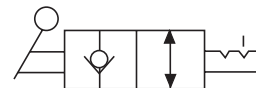

FOR PE30, PE46, AND
FOR PR10 SERIES (9561)

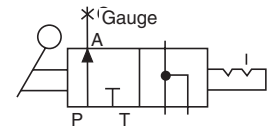

PE55 SERIES (9584)

! WARNING: Valve 9517 and 9561 work the same as a manifold if the pump is operated with the valve in the RELEASE position. In this position, the cylinder will advance when the pump is running and *retract* when the pump is stopped.

! DANGER: Never use valve 9517 and 9561 in the RELEASE position when lifting a load!

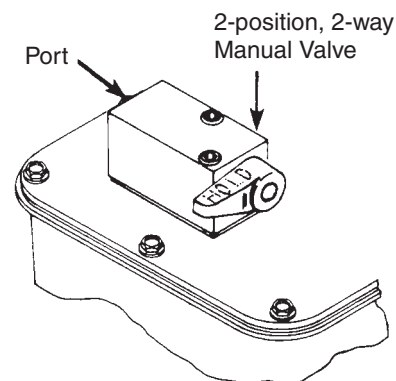
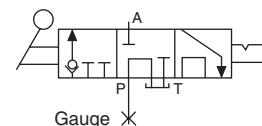

Figure 1

3-Position, 3-Way Manual Valve Used With Single-acting Cylinders

1. To hold pressure, turn the valve control handle clockwise (CW).
2. Activate the pump unit to advance the cylinder.
3. When the cylinder has advanced to the desired position, deactivate the switch or remote switch, or turn the pump unit OFF, or shift the valve to the center position. The cylinder will HOLD pressure.
4. To retract the cylinder, turn the valve control handle counterclockwise (CCW) slowly.



9520

! WARNING: When the valve is in the ADVANCE position, the cylinder will advance when the pump is running, and hold when the pump is stopped or the valve is in the CENTER position. The cylinder can be retracted by moving the valve to the RETRACT position.

VALVE OPTIONS CONTINUED -

3-Position, 4-Way Manual Valve used with Double-acting Cylinders

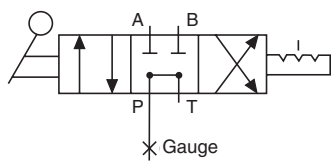

9500 (non posi-check)

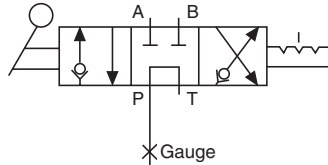

9506 (with posi-check)

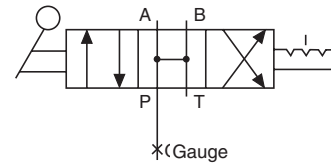

9511 (non posi-check)

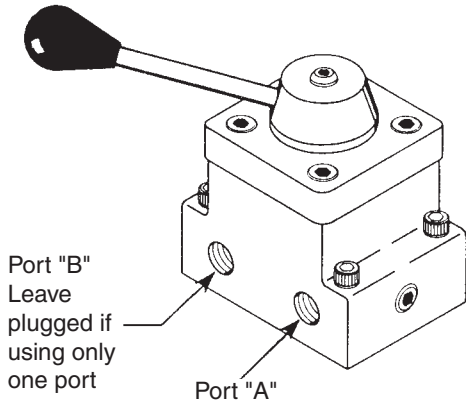

Figure 2

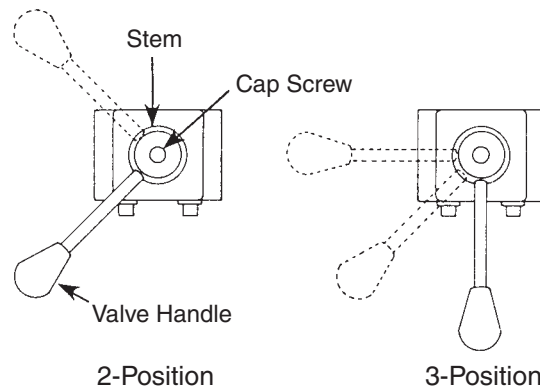

Figure 3

NOTE:

- This valve is a low torque design for use with double-acting or single-acting cylinder(s).
- If this valve is to be used as a 3-way with single-acting cylinder(s), one port (A or B) must remain plugged (use steel plug).
- Valve handle can be moved to the desired position by loosening the cap screw and rotating in increments of 22-1/2°.

1. Position the valve control lever in the NEUTRAL or HOLD position.
2. Activate the pump unit.
3. Advance the cylinder by shifting the valve control lever to the ADVANCE position.
4. When the cylinder has advanced to the desired position, turn the pump unit OFF, or shift the valve to the HOLD position.

NOTE: Non "posi-check" valves will momentarily lose pressure when shifting to HOLD position. See "posi-check" valve section of this form.

5. Retract the cylinder by shifting the valve control lever to the RETRACT position.
6. Activate the pump unit if using double-acting cylinders.

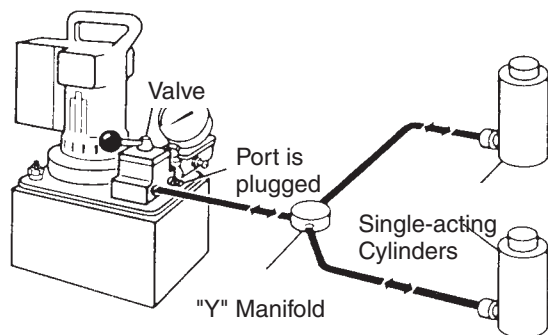

Examples of typical workholding applications:
SINGLE-ACTING CYLINDER(S) IN THE CIRCUIT
CONTROLLED BY A PUMP-MOUNTED VALVE

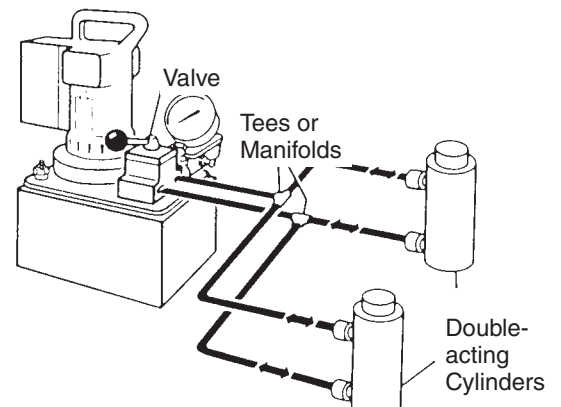

DOUBLE-ACTING CYLINDER(S) IN THE CIRCUIT
CONTROLLED BY A PUMP-MOUNTED VALVE

Other valves are available.
Consult your dealer, catalog or valve
operating instructions for details of operation.

VALVE OPTIONS CONTINUED -

"Posi-Check" Valves

If a "Posi-Check" open center valve is used, a hydraulic gauge in the gauge port shows zero pressure when the valve is switched to the neutral (hold) position. Cylinder pressure, however, is held without loss. **If reading the cylinder pressure, a gauge must be installed in the outlet port of the valve.**

To install a hydraulic gauge (refer to Figure 4):

1. Remove the pipe plug from the valve's gauge port.
2. Install a steel 45° elbow fitting.
3. Install the gauge into the 45° elbow fitting.

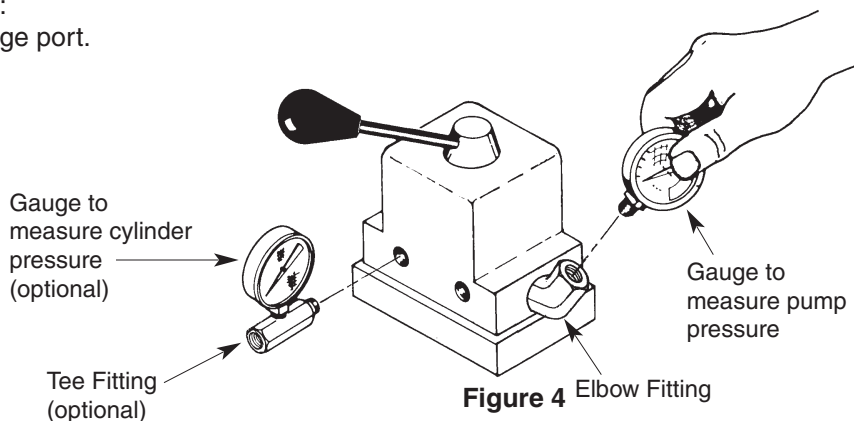
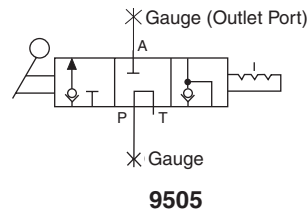

Automatic Dump Valve

1. Activate the pump unit to advance the cylinder.
2. Release the remote switch to release pressure and retract the cylinder.



DANGER: Never use this valve for lifting a load!

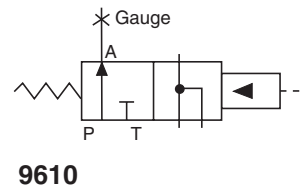

Solenoid Controlled, Pilot Operated Valve Used With Single-acting Cylinders

OPERATION

Neutral (HOLD): When neither solenoid is energized, fluid from pump is directed back to tank and fluid from cylinder is checked in the cylinder.

Advance: When solenoid "B" is energized, fluid from pump is directed through pressure port to cylinder.

Return: When solenoid "A" is energized, fluid from the pump and from the cylinder is directed back to tank.

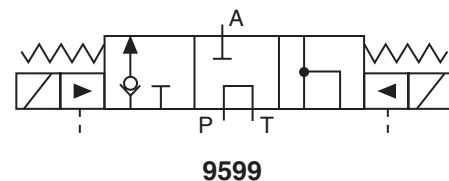

NOTE: Pressure holds without loss when shifted from cylinder port to the neutral (HOLD) position.

Solenoid Controlled, Pilot Operated Valve Used With Double-acting Cylinders

OPERATION

Neutral (HOLD): When both solenoids are de-energized, fluid from pump circulates at free flow from the pressure port "P" to tank "T". Both cylinder ports are blocked.

Solenoid "A" Energized: Pressure to cylinder port "A".
Cylinder port "B" to tank.

Solenoid "B" Energized: Pressure to cylinder port "B".
Cylinder port "A" to tank.

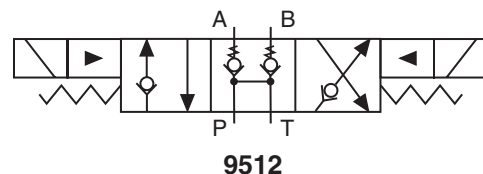

NOTE: Pressure holds without loss when shifted from cylinder port to the neutral (HOLD) position.

VALVE OPTIONS CONTINUED -

Solenoid Controlled, Air Operated Valve Used With Single- or Double-acting Cylinders

OPERATION

Position "A" (Air Port "A"): Pressure to Port "A". Port "B" to tank.

Position "B" (Air Port "B"): Pressure to Port "B". Port "A" to tank.

NOTE: All ports open to tank during transition between valve positions.

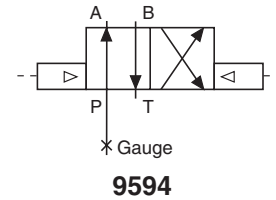

Single-acting, Spring Return Cylinder: Either fluid port "A" or "B" must be plugged with a steel plug on the valve. With port "B" plugged, the sequence of operation is as follows: When solenoid is energized to position "A", fluid port "A" becomes pressurized. When solenoid is energized to position "B", fluid port "A" becomes the return port.

Double-acting Cylinders: When operating double-acting cylinders, fluid port "A" can be connected to either the advance or return port of the cylinder and fluid port "B" will be connected to the remaining port. Sequence of operation is as follows: When solenoid is energized to position "A", port "A" becomes pressurized and extends the cylinder and fluid port "B" becomes the return port. When solenoid "B" is energized, the opposite of step 1 happens.

The application in Figure 5 represents a typical set-up using a control valve and multiple double-acting cylinders (one double-acting cylinder may be used). Interflow will occur.

If a different set-up or cylinder is being considered, contact your nearest Power Team facility.

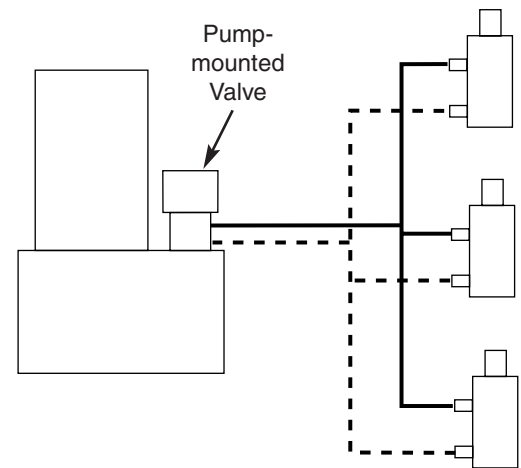

Figure

ADJUSTING THE PRESSURE REGULATING CONTROLS

The pressure regulating valve and pressure switch are shown in Figure 6. The pressure regulating valve can be adjusted to bypass fluid at a given pressure setting while the pump continues to run. The pressure switch can be adjusted to stop the pump at a given pressure setting. To ensure accuracy and low pressure differential (approx. 300 PSI [21 BAR]) throughout the pressure range (1,000 to 10,000 PSI [70 to 700 BAR] depending on the pump model), the pressure switch should be used with the pressure regulating valve. The pressure switch must be set at a pressure lower than the pressure regulating valve to work properly.

ADJUSTING THE PRESSURE REGULATING CONTROLS CONTINUED -

Adjusting The Pressure Regulating Valve

NOTE: For easy adjustment of the pressure regulating valve, always adjust the pressure by *increasing* to the desired pressure setting.

1. Loosen the locknut (B) on the pressure regulating valve, and back the adjusting screw or knob (A) out a few turns by turning it in a counterclockwise (CCW) direction. This will *decrease* the setting to a lower than desired pressure.
2. The pump must be completely connected electrically and hydraulically. Start the pump.
3. Slowly turn the adjusting screw or knob (A) in a clockwise (CW) direction. This gradually *increases* the pressure setting. When the desired pressure is reached, lock the adjusting screw (A) in position by tightening the locknut (B). Shut off the pump.

IMPORTANT:

- The pressure range is from 1,000 to 10,000 PSI (70 to 700 BAR) depending on the pump model.
- The pressure switch must be set at a higher pressure than working range to prevent shut down during adjustment.

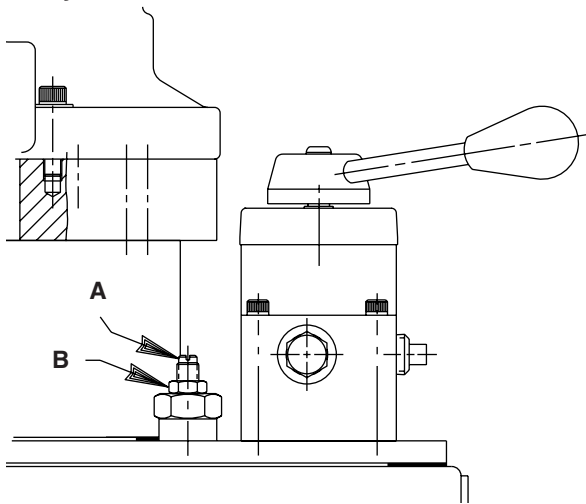
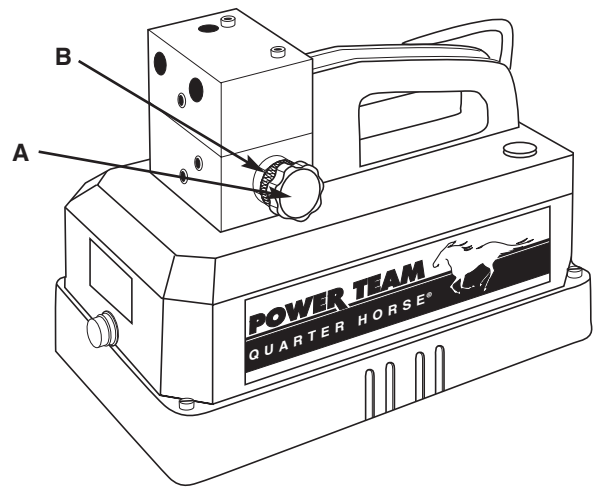

Figure 6



Adjusting The Pressure Switch

Generally, the pressure switch should be used with the pressure regulating valve. A pressure switch can be used *alone* for operating electrical devices such as motors, solenoids, relays, etc., which are located elsewhere in the circuit. Refer to Figure 7.

1. Loosen the locknut (B) on the pressure switch, and turn adjusting screw (A) in a clockwise (CW) direction. This *increases* the pressure setting to a higher than desired pressure.
2. Adjust the pressure regulating valve to the desired pressure setting. Refer to the section titled "Adjusting The Pressure Regulating Valve".
3. With the pump running and bypassing fluid at the desired pressure, slowly turn the pressure switch adjusting screw (A) in a counterclockwise (CCW) direction, *decreasing* the pressure switch setting until the pump motor shuts off. Then lock the adjusting screw (A) in position by tightening the locknut (B).
4. Release pressure. Run the pump to check the pressure setting and cut-out of the motor. If may be necessary to make a second adjustment.

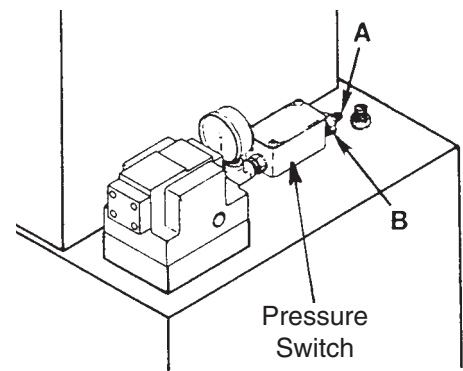

Figure 7

NOTE: When the pressure switch setting is reached, the motor will shut off. However, the inertia of the motor continues to deliver fluid for a brief period. The pressure regulating valve bypasses this surplus hydraulic fluid, preventing it from going into the system. As a result, the pressure differential can be held to approximately 300 PSI (21 BAR).

PREVENTIVE MAINTENANCE



WARNING: To help prevent personal injury,

- Disconnect the pump from the power supply before performing maintenance or repair procedures.
- Repairs and maintenance are to be performed in a dust-free area by a qualified technician.

Checking The Hydraulic Fluid And Filling The Reservoir (Except Bladder Type, See Below)

The hydraulic fluid level should be checked after initial set-up and after each ten hours of use.

1. Thoroughly clean the area around the filler cap with a clean cloth to prevent contamination of the hydraulic fluid.
2. Cylinder(s) must be fully retracted and the power supply disconnected.
3. Remove the filler cap and insert a clean funnel with filter. Fill to proper level as instructed in "Filling The Pump Reservoir Or Bladder" under Set-up Instructions.
4. Replace filler cap.
5. The frequency of fluid changes will depend upon the general working conditions, severity of use, and overall cleanliness and care given the pump. Three hundred hours of use under general shop conditions is considered a standard change interval. Drain, clean, and refill the reservoir with a high grade hydraulic fluid.

Checking The Hydraulic Fluid And Filling The Bladder

The hydraulic fluid level should be checked after initial set-up and after each ten hours of use.

1. Thoroughly clean the area around the filler cap with a clean cloth to prevent contamination of the hydraulic fluid.
2. Cylinder(s) must be fully retracted and the power supply disconnected. Position the pump with the filler plug in the up (or vertical) position.
3. Remove the filler cap and insert a clean funnel with filter. Fill the bladder completely full with a high grade hydraulic fluid.
4. Replace filler cap. **IMPORTANT: Tighten filler cap 1/2 - 1 turn after o-ring contacts sealing surface. Overtightening can cause pump damage on bladder equipped pumps.**
5. The frequency of fluid changes will depend upon the general working conditions, severity of use, and overall cleanliness and care given the pump. Three hundred hours of use under general shop conditions is considered a standard change interval. Drain, clean, and refill the reservoir with a high grade hydraulic fluid.

Maintenance Cleaning

IMPORTANT: Never use a high pressure washer to clean hydraulic components!

1. Keep the pump's outer surface as free from dirt as possible.
2. Seal all unused couplers with thread protectors.
3. Keep all hose connections free of dirt and grime.
4. The breather-hole in the filler cap must be clean and unobstructed at all times.
5. Equipment connected to the pump must be kept clean.
6. Use a high grade hydraulic fluid in this pump. Change as recommended (every 300 hours). Some conditions may require the use of different viscosity hydraulic fluids.

Lubrication (Air Driven Motor Only)

If the pump is operated on a continuous duty cycle or a maximum speeds for extended periods, an automatic air line oiler should be installed in the air inlet line as close to the pumping unit as possible. Set the unit to feed 1-3 drops of oil per minute (one drop for every 65 CFM [1,8 M³/min.] of air) into the system, or refer to the pump manufacturer's instructions. Use SAE No. 10 oil.

Engine Oil (Gas Engine Only)

Change engine oil as recommended for four stroke engines.

Mix the correct oil into fuel in proper ratio as recommended for two stroke engines.

Reservoir Vent Air Filter (Optional for all pumps except PR10 series)

1. Remove the filler cap, and insert either the 45° fitting or the straight fitting. Fasten o-ring end of fitting into pump.
2. If the 45° fitting is used, place the rubber spacer (included) on the top threaded portion.
Then thread the air filter on and hand tighten.
3. If the straight fitting is used, thread the air filter on and hand tighten.

PREVENTIVE MAINTENANCE CONTINUED -

Draining And Cleaning The Reservoir (Except Bladder Type, See Below)

IMPORTANT: Clean the pump exterior before the pump interior is removed from the reservoir.

1. Remove the screws fastening the motor and pump assembly to the reservoir. **IMPORTANT: Do not damage the gasket or pump filter or pressure regulating valves when lifting the pump and motor off the reservoir.**
2. Clean the inside of the reservoir and clean the filter.
3. Place the pump and motor assembly back onto the reservoir, and secure with machine screws.
4. Fill the reservoir with a clean, high grade hydraulic fluid (refer to "Filling The Pump Reservoir Or Bladder" under Set-up Instructions for proper fluid level for your pump).

Draining And Cleaning The Bladder

IMPORTANT: Clean the area around the filler hole to prevent contamination of the hydraulic fluid.

1. Remove the filler plug and drain hydraulic fluid completely.
2. Fill bladder half full with clean hydraulic fluid. Flush bladder with clean fluid and drain. **IMPORTANT: Never use solvents to clean the bladder! Never disassemble the bladder from the pump!**
3. Fill the bladder completely full with a clean, high grade hydraulic fluid.

TROUBLE-SHOOTING GUIDE



WARNING

- To help prevent personal injury, any repair work or trouble-shooting must be done by qualified personnel familiar with this equipment.
- Use the proper gauges and equipment when trouble-shooting.

NOTE:

- For a detailed parts list or to locate a Power Team Authorized Hydraulic Service Center contact your nearest Power Team facility.
- It is best to check for system leaks by using a hand pump and applying pressure to the suspect area. Watch for leaking fluid and follow it back to its source. *Never* use your hand or other body parts to check for a possible leak.

PROBLEM	CAUSE	SOLUTION
Electric motor does not run	<ol style="list-style-type: none"> 1. Pump not turned ON. 2. Unit is not plugged in. 3. No voltage supply. 	<ol style="list-style-type: none"> 1. Set switch to "ON" position. 2. Plug in unit. 3. Check line voltage. Check reset button or fuse on power panel.
WARNING: To help prevent personal injury, disconnect power supply before removing cover. Any electrical work should be performed by a qualified electrician.	<ol style="list-style-type: none"> 4. Pressure switch not set properly. 5. Broken lead wire or defective power cord plug. 6. Overheated motor has caused overcurrent protection to disengage. 	<ol style="list-style-type: none"> 4. Refer to "Adjusting The Pressure Switch" information under "Adjusting The Pressure Regulating Controls" section. 5. Contact a Power Team Authorized Hydraulic Service Center. 6. Wait for motor to cool before restarting.
Electric motor will not shut off.	<ol style="list-style-type: none"> 1. Defective motor controls. 	<ol style="list-style-type: none"> 1. Disconnect from power supply and contact a Power Team Authorized Hyd. Service Center.
Electric motor stalls, surges, overheats or will not start under a load.	<ol style="list-style-type: none"> 1. Low voltage or electrical cord size too small. 	<ol style="list-style-type: none"> 1. Refer to the "Electric Pump" information under "Pump Operation" section.

TROUBLE-SHOOTING GUIDE CONTINUED -

PROBLEM	CAUSE	SOLUTION
Electrical overload protector keeps tripping.	1. Wired incorrectly.	1. See Service Bulletin #9903PT at the end of this document.
Pump is not delivering fluid or delivers only enough fluid to advance cylinder(s) partially or erratically.	1. Fluid level too low. 2. Quick disconnect couplings are not completely coupled. 3. Air in system. 4. Cold fluid or fluid too viscous. 5. Reservoir capacity is too small for the size of cylinder(s) used. 6. Three phase motor rotating in wrong direction. 7. PR10 series pump not connected to correct 12 VDC polarity. 8. Vacuum in reservoir.	1. Fill reservoir or bladder according to directions "Filling The Pump Reservoir Or Bladder" under "Set-up Instructions" section 2. Check quick-disconnect couplings to cylinders to ensure that they are completely coupled. Occasionally couplers have to be replaced because the ball check does not stay open due to wear. 3. Refer to the section titled "Bleeding the System" under "Set-up Instructions" section. 4. Hydraulic fluid is of a higher viscosity than necessary. Change to a lighter fluid. 5. Use smaller cylinder(s) or larger reservoir. 6. Refer to electrical schematic on motor. 7. Connect to correct 12 VDC polarity. 8. Check for plugged vent in filler plug.
Pump builds pressure but cannot maintain pressure.	1. External leaks. 2. Internal or external leakage on hydraulic cylinder. 3. Leaking control valve or check valve.	1. Seal leaking pipe fittings with pipe sealant. Replace leaking pipes or hoses. 2. Remove the cylinder from pump. If the pump builds and maintains full pressure, the cylinder is defective. Contact a Power Team Authorized Hydraulic Service Center. 3. Contact a Power Team Authorized Hyd. Service Center.
Pump will not build full pressure.	1. Faulty pressure gauge. 2. Check for external leakage. 3. Improperly adjusted external pressure regulator setting. 4. Internal or external leakage on hydraulic cylinder.	1. Calibrate gauge. 2. Seal faulty fittings with sealant. Replace leaking pipes or hoses. 3. Refer to "Adjusting The Pressure Regulator Valve" information under "Adjusting the Pressure Regulating Controls" section. 4. Remove the cylinder from the pump. If the pump builds full pressure, the cylinder is defective. Contact a Power Team Authorized Hyd. Service Center.

TROUBLE-SHOOTING GUIDE CONTINUED -

PROBLEM	CAUSE	SOLUTION
Pump will not build full pressure. (continued)	5. Inadequate power supply. 6. Leaking control valve or defective pump.	5. Refer to "Air Pump" or "Electric Pump" information under "Pump Operation" section. 6. Contact a Power Team Authorized Hydraulic Service Center.
Cylinder(s) will not retract or extend.	1. Quick disconnect couplings are not completely coupled.  DANGER: A double-acting cylinder or ram must have <u>both</u> hoses and all couplers securely connected to both ports. If one of the two ports is restricted or becomes disconnected, pressure will build and the cylinder, hose or coupler can burst, possibly causing serious injury or death. 2. Broken return spring in spring return cylinder or seals blown in double-acting cylinder.	1. Check quick disconnect coupling to cylinders to ensure that they are completely coupled. Occasionally couplers have to be replaced because the ball check does not stay open due to wear. 2. Contact a Power Team Authorized Hydraulic Service Center.
Pump delivers excess oil pressure.	1. Faulty pressure gauge. 2. Relief valve not properly set.	1. Calibrate gauge. 2. Contact a Power Team Authorized Hydraulic Service Center.

POWER TEAM FACILITIES



 **UNITED STATES**
 SPX Corporation-Fluid Power
 5885 11th Street
 Rockford, IL 61109-3699
 USA
 Telephone: 1-815-874-5556
 FAX: 1-815-874-7853

Cust. Service/Order Entry
 Tel: 1-800-541-1418
 FAX: 1-800-288-7031
E-mail:
 info@fluidpower.spx.com

Technical Services
 Tel: 1-800-477-8326
 FAX: 1-800-765-8326

 **CHINA**
 212 Jiang Ning Road
 CATIC Tower 23C
 Shanghai 200041, China
 Tel: 86 (21) 5289 5858
 FAX: 86 (21) 5289 5866
E-mail:
 info.asia@fluidpower.spx.com

 **FAR EAST**
 7 Gul Circle
 Singapore 629563
 Singapore
 Tel: (65) 6265-3343
 FAX: (65) 6265-6646
E-mail:
 info.asia@fluidpower.spx.com

 **EUROPE**
 Albert Thijsstraat 12
 6471 WX Eyselshoven
 Netherlands
 Tel: 31 (45) 5678877
 FAX: 31 (45) 5678878
E-mail
 info.europe@fluidpower.spx.com

Parts List for:

4044-50-220
4046-50-220
HE172 (220V, 50 Hz)
HE174 (220 V., 50 Hz)

PE17-AMKUS
PE172-50-220
PE172A-50-220
PE172-CCL
PE174-50-220

ELECTRIC HYDRAULIC PUMP

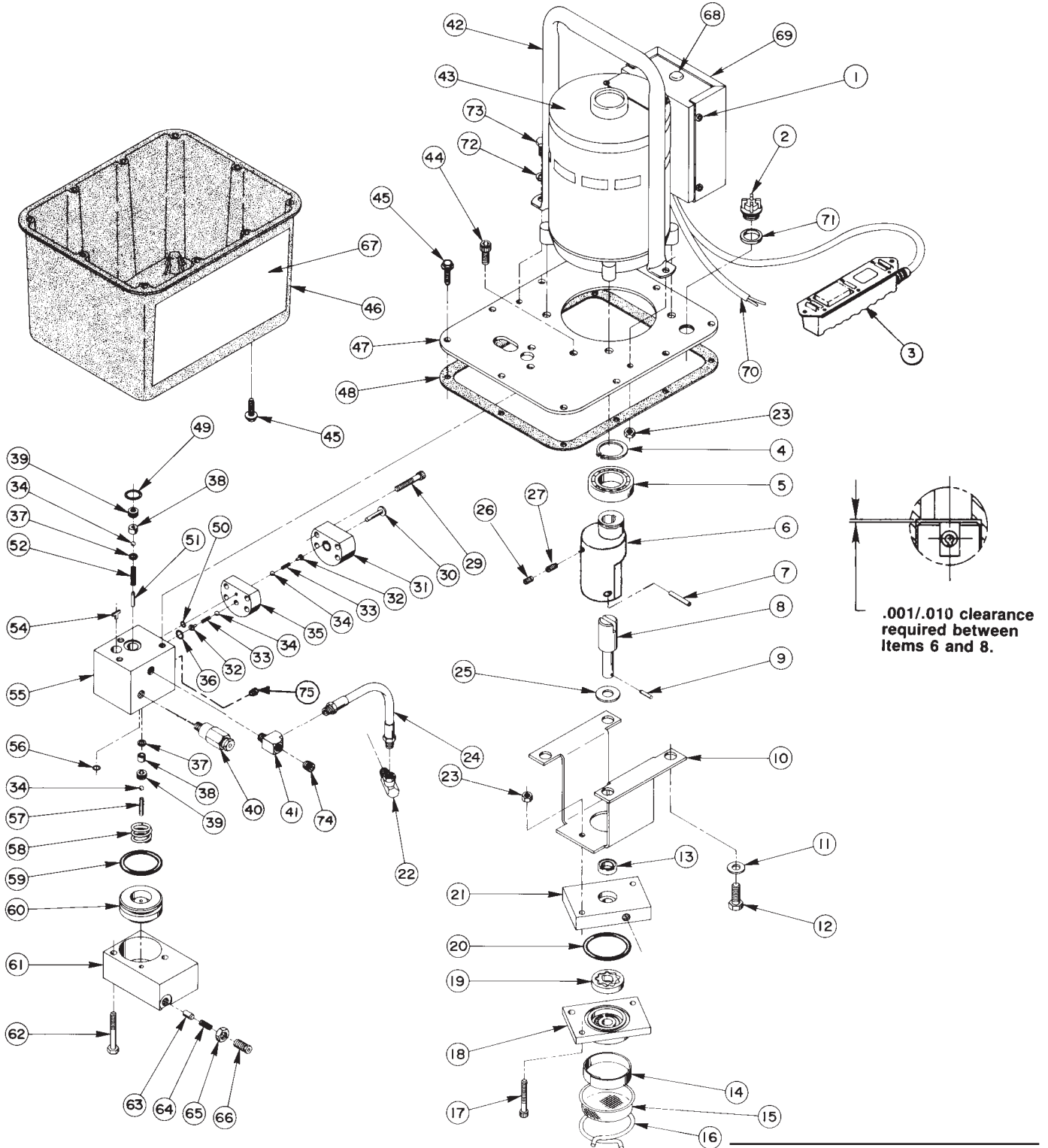

Note: Shaded areas reflect last revision(s) made to this form.

Parts List, Form No. 100585, Back sheet 1 of 4

Item No.	Part No.	No. Req'd	Description
1	11141	4	Self-Tapping Screw (#6-20 X 3/8 Lg.)
2	20937	1	Filler/Vent Plug
	†27142	1	Filler/Vent Plug
3	25017	1	Remote Hand Switch Assembly (See Back sheet 4 of 4)
4	209798	1	Retaining Ring
5	209805	1	Ball Bearing
6	45596	1	Eccentric
7	10973	1	Slotted Spring Pin
8	304835	1	Drive Shaft
9	209794	1	Gerotor Drive Pin
10	52174	1	Pump Mounting Bracket
11	10258	4	Washer
12	213663	4	Screw (3/8-16 UNC X 1" Lg.; Torque to 230/250 in. lbs.)
13	*304830	1	Seal
	†250156	1	Seal
14	21846	1	Filter Support
15	21608	1	Filter
16	11461	1	Clamp Ring
17	10854	2	Cap Screw (1/4-20 UNC X 1-3/4 Lg.; Torque to 60/80 in. lbs.)
18	61169	1	Lower Gerotor Housing
	45912	1	Lower Gerotor Housing (For PE17-AMKUS)
19	304826	1	Gerotor Set
20	*10922	1	O-ring (2-1/8" X 1-15/16" X 3/32)
	†250158	1	O-ring (2-1/8" X 1-15/16" X 3/32)
21	61170	1	Upper Gerotor Housing
	45913	1	Upper Gerotor Housing (For PE17-AMKUS)
22	14440	1	Swivel Elbow Fitting
23	10199	4	Nut
24	304819	1	Hose Assembly
25	12595	1	Brass Washer
26	10519	1	Set Screw (1/4-20 UNC X 3/8 Lg.; Torque to 60/80 in. lbs.)
27	10136	1	Set Screw (1/4-20 X 1/4 Lg.; Torque to 60/80 in. lbs.)
29	10022	4	Cap Screw (1/4-20 UNC X 1-1/2" Lg.; Torque to 110/130 in. lbs.)
30	304820	1	High Pressure Piston
31	45560	1	Piston Block
32	24549	2	Valve Guide
33	*10445	2	Compression Spring (5/32 O.D. X 3/4 Lg.)
34	*12223	4	Ball
35	45559	1	Check Block
36	*14763	1	O-ring (7/16 X 5/16 X 1/16)
	†13472	1	O-ring (7/16 X 5/16 X 1/16)
37	*10442	2	Copper Washer
38	*209787	2	Replaceable Seat
39	209797	2	Hollow Lock Screw (7/16-20 UNF-3A; Torque to 110/130 in. lbs.)
40	21278	1	Relief Valve Assembly (Set at 10,100/10,700 PSI)
	21278-6	1	Low Pressure Relief Valve (For PE17-AMKUS, Set at 600/640 PSI)
	207975-105	1	Relief Valve (For PE172-CCL; 10,500 PSI)
41	19463	1	Tee Fitting
42	47492	1	Handle
43	58196WH2	1	Electric Motor
	250313	1	Electric Motor (For PE17-AMKUS; includes toggle switch and power cord)
44	10030	1	Cap Screw (5/16-18 UNC X 3/4 Lg.; Torque to 220/240 in. lbs.)
45	209799	14	Self-Tapping Screw (1/4-10 X 7/8 Lg.; For plastic reservoir)
46	61165	1	Reservoir

Note: Shaded areas reflect last revision(s) made to this form.

Item No.	Part No.	No. Req'd	Description
47	61166BK2	1	Cover Plate
48	*40164	1	Cover Gasket
49	*10273	1	O-ring (13/16 X 5/8 X 3/32)
	† 250157	1	O-ring (13/16 X 5/8 X 3/32)
50	*10265	1	O-ring (5/16 X 3/16 X 1/16)
	† 17714	1	O-ring (5/16 X 3/16 X 1/16)
51	12149	1	Dowel Pin
52	*16057	1	Compression Spring
54	209795	1	Outlet Ball Stop
55	61167	1	Check Body
56	*10266	1	O-ring (3/8 X 1/4 X 1/16)
	† 17715	1	O-ring (3/8 X 1/4 X 1/16)
57	211843	1	Dowel Pin (Loctite pin in piston hole with radius end out)
58	*16346	1	Compression Spring (1" O.D. X 7/8 Lg.)
59	*10283	1	O-ring (2" X 1-5/8 X 3/16)
	† 250159	1	O-ring (2" X 1-5/8 X 3/16)
60	46063	1	Auto. Valve Piston
61	*52167	1	Auto. Valve Block
62	13037	2	Cap Screw (1/4-20 UNC X 2" Lg.; Torque to 40/50 in. lbs.)
63	15156	1	Dowel Pin (Tapered end toward spring.)
	211170	1	Dowel Pin (For PE17-AMKUS; Tapered end toward threaded plug.)
64	*11221	1	Compression Spring (1/4 O.D. X 1" Lg.)
65	10386	1	Locknut
66	29786	1	Adjusting Screw
	10047	1	Adjusting Screw (For PE17-AMKUS)
67	304840	2	Trade Name Decal (For 4044-50-220)
	304841	2	Trade Name Decal (For PE Series)
	305101	2	Trade Name Decal (For HE172)
	305257	2	Trade Name Decal (For HE174)
	307137	2	Trade Name Decal (For 4046-50-220)
68	17782	1	Snap Button
69	42576WH2	1	Control Box Cover
70	12293	1	Power Cord
71	200415	1	Rubber Seal
	† 17723	1	Rubber Seal
72	10245	2	Lockwasher
73	10009	2	Cap Screw (1/4-20 UNC X 3/4 Lg.; Torque to 60/80 in. lbs.)
74	10427	1	Pipe Plug (1/8 NPTF)
75	15130	1	Pipe Plug (1/16 NPTF)

PARTS INCLUDED BUT NOT SHOWN

*200188	1	Warning Decal
† 11278	1	Tube Elbow
† 15061	1	Male Connector
† 251229	1	Oil Line
† 250328	1	Decal (EPR Seals)
351060	1	Gasket (Between motor and cover plate)
10020	3	Cap Screw (1/4-20 X 1-1/4" Lg.; For PE17-AMKUS)
18969	1	Tee Fitting (For PE17-AMKUS)
211594	2	Rubber Bumper (For PE17-AMKUS)
250607	2	Seal Washer (For PE172-CCL)
25600-1	1	Cylinder Half Coupler (For PE172-CCL)
9040	1	Gauge (10,000 PSI; For PE172-CCL)
9670	1	Tee Fitting (For PE172-CCL)
9797	1	Dust Cap (For PE172-CCL)

Note: Shaded areas reflect last revision(s) made to this form.

OPTIONAL VALVE ASSEMBLIES

4-Way Tandem Center Directional Valve

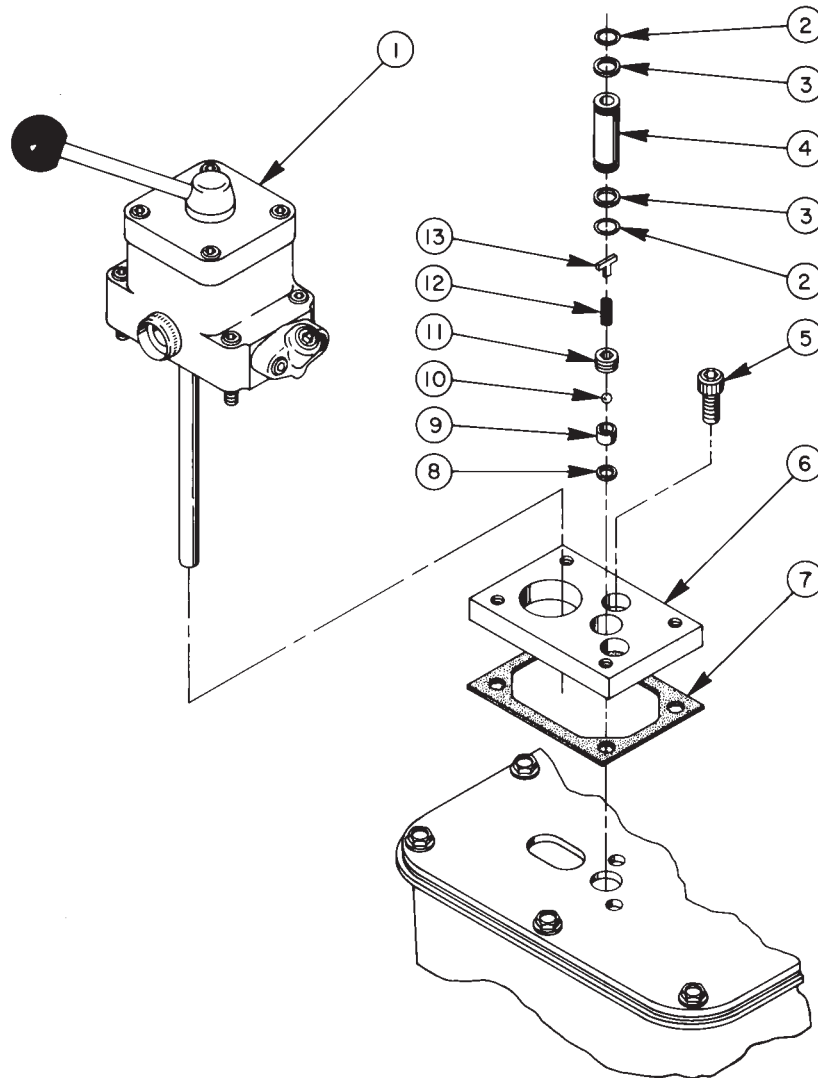

Item No.	Part No.	No. Req'd	Description
1	9500	1	4-Way Valve Ass'y (See Form No. 100623)
2	•*10268	2	O-ring (1/2 X 3/8 X 1/16)
	†17716	2	O-ring (1/2 X 3/8 X 1/16)
3	•*11863	2	Backup Washer
4	209809	1	Coupling
5	10030	2	Cap Screw (5/16-18 UNC X 3/4 Lg.; Torque to 220/240 in. lbs.)
6	52165	1	Adapter Block Manifold

Item No.	Part No.	No. Req'd	Description
7	*200395	1	Gasket
8	•*10442	1	Copper Washer
9	•*209787	1	Replaceable Seat
10	•*12223	1	Steel Ball
11	209797	1	Hollow Lock Screw (7/16-20 UNF-3A; Torque to 110/130 in. lbs.)
12	*211797	1	Compression Spring (5/32 O.D. X 5/8 Lg.)
13	•209795	1	Outlet Ball Stop

Part numbers marked with an asterisk (*) are contained in Repair Kit No. 300430.
 Part numbers marked with a dagger (†) are contained in EPR Seal Kit No. 300648.
 Part numbers marked with a bullet (•) are contained in Outlet Check Repair Kit No. 300606.

Two Position, 2-Way Manual Valve

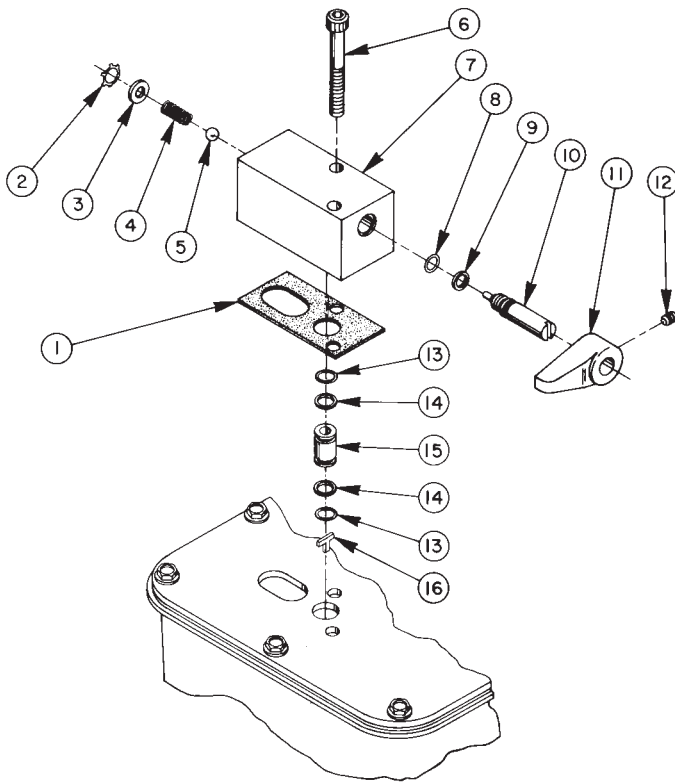

Item No.	Part No.	No. Req'd	Description
1	*304829	1	Gasket
2	*11088	1	Retaining Ring
3	11089	1	Washer
4	*11024	1	Compression Spring (1/4 O.D. X 5/8 Lg.)
5	*10375	1	Steel Ball
6	209945	2	Cap Screw (5/16-18 UNC X 2-1/2 Lg.; Torque to 220/240 in. lbs.)
7	52168	1	Valve Body
8	*10267	1	O-ring (7/16 X 15/16 X 1/16)
	†13472	1	O-ring (7/16 X 15/16 X 1/16)
9	*15085	1	Backup Washer
10	304849	1	Release Valve Screw
11	213109	1	Release Valve Handle
12	10556	1	Set Screw (1/4-20 UNC X 1/4 Lg.)
13	*10268	2	O-ring (1/2 X 3/8 X 1/16)
	†17716	2	O-ring (1/2 X 3/8 X 1/16)
14	*11863	2	Backup Washer
15	202505	1	Coupling
16	209795	1	Outlet Ball Stop (Part of the Basic Pump Ass'y)
	52170	1	Complete Valve Ass'y (Consists of items 1 thru 15)

Part numbers marked with an asterisk (*) are contained in Repair Kit No. 300430.
 Part numbers marked with a dagger (†) are contained in EPR Seal Kit No. 300648.

Manifold Assembly

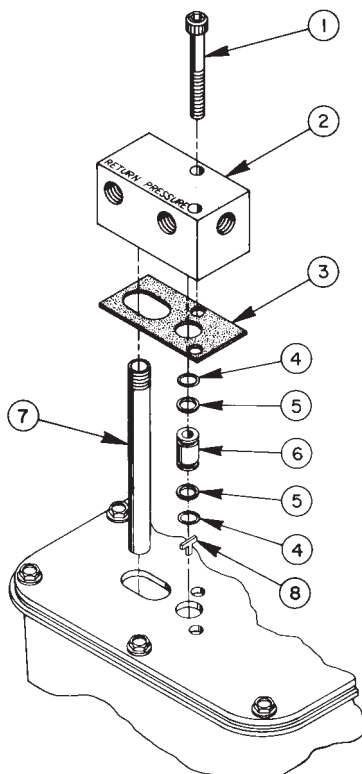

Item No.	Part No.	No. Req'd	Description
1	209945	2	Cap Screw (5/16-18 UNC X 2-1/2 Lg.; Torque to 220/240 in. lbs.)
2	45554	1	Manifold
3	*304829	1	Gasket
4	*10268	2	O-ring (1/2 X 3/8 X 1/16)
	†17716	2	O-ring (1/2 X 3/8 X 1/16)
5	*11863	2	Backup Washer
6	202505	1	Coupling
7	200609	1	Drain Line
8	209795	1	Outlet Ball Stop (Part of the Basic Pump Ass'y)

Part numbers marked with an asterisk (*) are contained in Repair Kit No. 300430.
 Part numbers marked with a dagger (†) are contained in EPR Seal Kit No. 300648.

MOTOR CONTROL ASSEMBLY

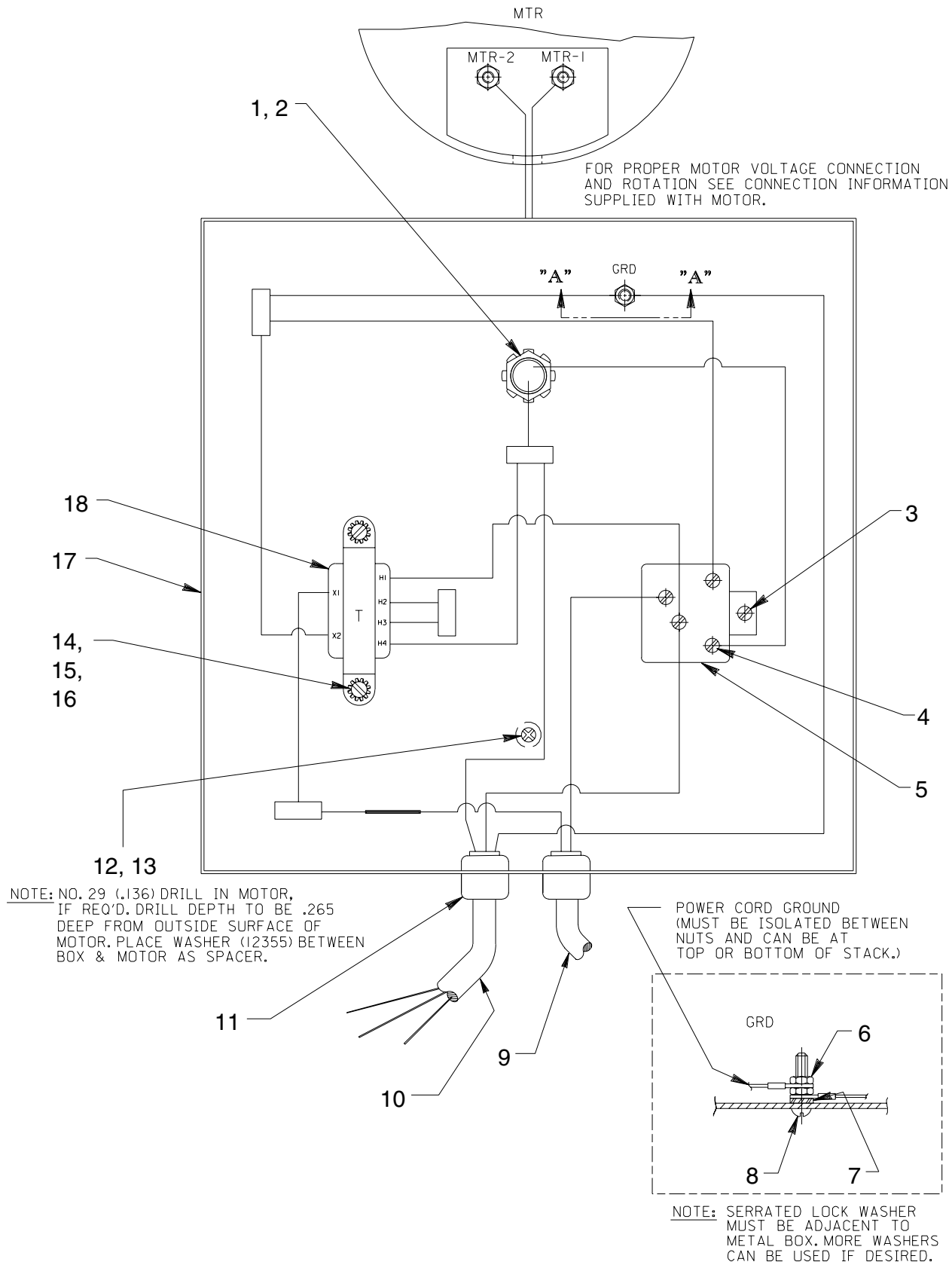

Note: Shaded areas reflect last revision(s) made to this form.

VIEW **A-A**
(NOT PART OF PE172-CCL)

Item No.	Part No.	No. Req'd	Description	Item No.	Part No.	No. Req'd	Description
1	11202	1	Nipple	10	12293	7.25 ft.	Power Cord
3	17370	1	Screw (6-20 X 1/4 Lg.)	11	15993	2	Bushing
4	10975	4	Machine Screw (#8-32 UNC X 5/16 Lg.)	12	252253	1	Screw (#8-32 X 1/2 Lg.)
5	14667	1	Starter	13	12355	1	Washer
6	10197	1	Nut	14	10962	2	Mach. Screw (8-32 UNC X 1/2 Lg.)
7	11108	1	Washer	15	10196	2	Nut
8	10167	1	Machine Screw (10-24 UNC X 3/4 Lg.)	16	11388	2	Lockwasher
9	25017	1	Remote Hand Switch (See Back sheet 4 of 4.)	17	42575WH2	1	Elect. Control Box
				18	305665	1	Transformer

ELECTRIC SCHEMATIC

220 V., 50 Hz.

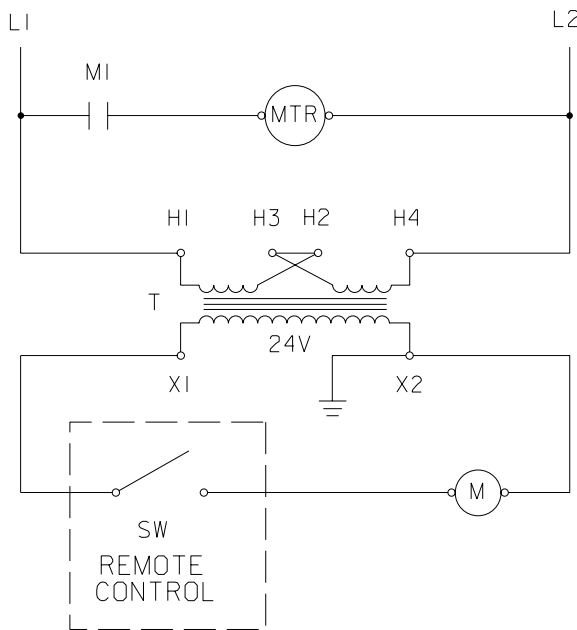

Note: Shaded areas reflect last revision(s) made to this form.

WARNING

To help avoid personal injury, all electrical work must be done by a qualified electrician.

North American & International Color Codes

Conductors	North American	International
Line	Black	Brown
Neutral	White	Blue
Ground	Green	Green/Yellow

ASSEMBLY INSTRUCTIONS

After all components have been installed and torqued, the electric motor/gerotor shafts must turn freely when rotated by hand. If binding is encountered, proceed as follows:

1. Loosen electric motor mounting screws and gerotor housing bolts.
2. Retighten screws finger tight.
3. Rotate shafts by hand until free (no binding).
4. Retorque per print.
5. Rotate shafts again by hand to verify that binding is not encountered after torquing.

Adjust the alignment of the low pressure pump section and the alignment of the high pressure pump section to reduce noise to a minimum. Torque screw #10030 (Item #44 on sheet 1 of 4) and screws #209945 (Item #6 on sheet 3 of 4, if pump is equipped with a two position, 2-way valve. Item #1 on sheet 3 of 4, if pump is equipped with a manifold.) or screws #10030 (Item #5 on sheet 3 of 4, if pump is equipped with a 4-way tandem valve) before testing and after any alignment of the high pressure pump section. Always replace washers #10258 (Item #11 on sheet 1 of 4) if the low pressure pump section has been realigned and the washers have been deformed.

REMOTE HAND SWITCH ASSEMBLY

No. 25017

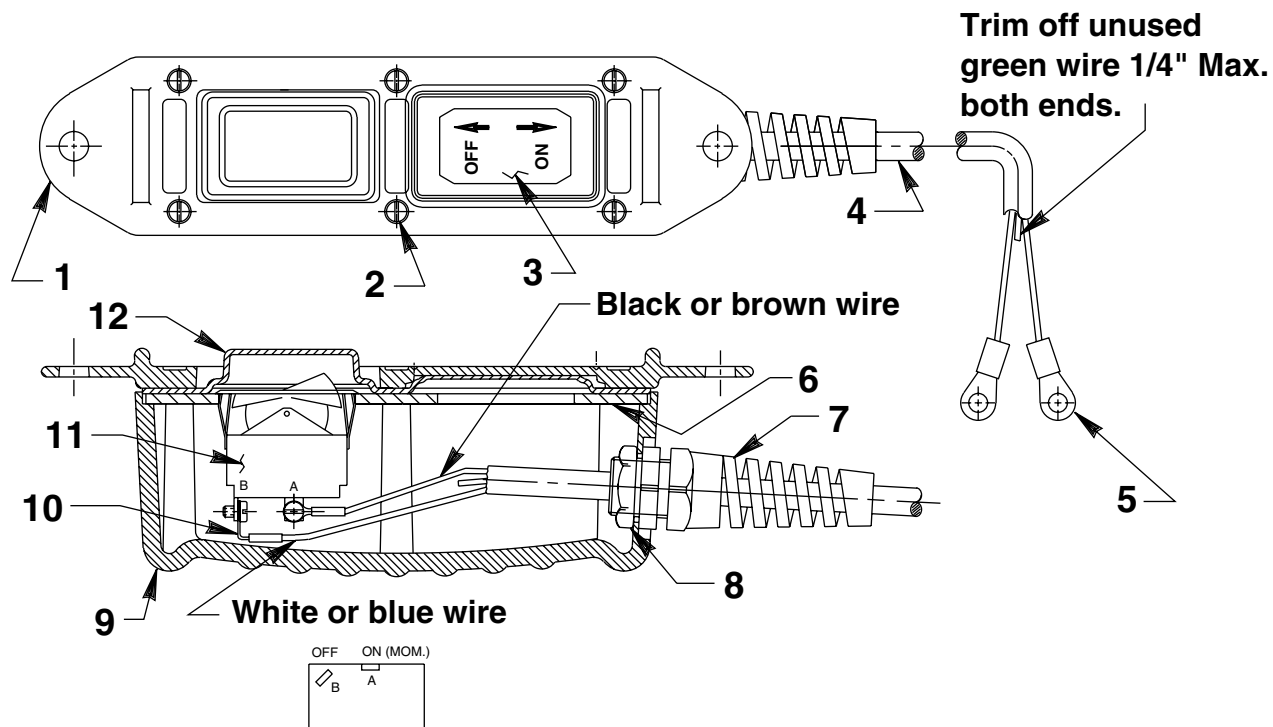

Item No.	Part No.	No. Req'd	Description
1	420050-1	1	Cover
2	250248	6	Screw (4-24 x 3/4 Lg.)
3	202763	1	Decal
4	12908	11 ft.	Cable (18/3 SJTO)
5	10458	2	Ring Terminal
6	420050-3	1	Switch Mounting Plate
7	251818	1	Strain Relief Connector
8	251802	1	Locknut (3/4-16 UNF; Torque to 30/35 in. lbs.)
9	420050-4	1	Switch Housing
10	10525	2	Ring Terminal
11	16772	1	Rocker Switch
12	420050-2	1	Gasket

Note: This page was added at the last revision(s) made to this form.

Refer to any operating instructions included with this product for detailed information about operation, testing, disassembly, reassembly, and preventive maintenance.

Items found in this parts list have been carefully tested and selected. **Therefore: Use only genuine replacement parts!**

Additional questions can be directed to our Technical Services Department.