

PNEUTORQUE[®]

PTS[™]

500/800/1000/1350/2000/2700/4000/7000

REMOTE CONTROL AIR MOTOR



CONTENTS

Part Numbers Covered by This Manual	2
Safety	3
Introduction	7
Parts Included	7
Explanation of Data Label	7
Accessories	8
Features and Functions	10
Set up Instructions	11
1. Torque Reaction	11
2. Air Lubrication	12
3. Tool Control Systems	12
4. Input Ports	13
5. Exhaust Port	14
6. Setting Torque for Fastener Tightening	14
Operating Instructions	15
Tightening	15
Releasing	15
Maintenance	16
Air Lubrication	16
Gearbox	16
Silencer	16
Drive Square	17
Calibration	17
Cleaning	17
Disposal	17
Specifications	18
EU Declaration of Incorporation	20
Trouble Shooting	21
Glossary of Terms	21

PART NUMBERS COVERED BY THIS MANUAL

This manual covers all PTS™ series remote control tools, including the following:

Part Number	Model	Direction	Maximum Torque
180271.B06	PTS™-52-500	Bi-directional	500 N·m
180272.B06	PTS™-52-800	Bi-directional	800 N·m
180273.B06	PTS™-72-1000	Bi-directional	1000 N·m
180274.B08	PTS™-72-1350	Bi-directional	1350 N·m
180275.B08	PTS™-72-2000	Bi-directional	2000 N·m
180276.B08	PTS™-80-2700	Bi-directional	2700 N·m
180277.B08	PTS™-92-4000	Bi-directional	4000 N·m
180277.B12	PTS™-92-4000	Bi-directional	4000 N·m
180279.B12	PTS™-119-7000	Bi-directional	7000 N·m

PTS™ tools are also available with a pistol grip handle, see operator's manual part number 34438.

SAFETY

IMPORTANT: THIS OPERATOR'S MANUAL SHOULD BE KEPT FOR FUTURE REFERENCE.

General Safety Rules:

- For multiple hazards, read and understand the safety instructions before installing, operating, repairing, maintaining, changing accessories on, or working near the assembly power tool for threaded fasteners. Failure to do so can result in serious bodily injury.
- Only qualified and trained operators should install, adjust or use the assembly power tool for threaded fasteners.
- Do not modify this assembly power tool for threaded fasteners. Modifications can reduce the effectiveness of safety measures and increase the risks to the operator.
- Do not discard the safety instructions; give them to the operator.
- Do not use the assembly power tool for threaded fasteners if it has been damaged.
- Tools shall be inspected periodically to verify that the ratings and markings required are legibly marked on the tool. The employer/user shall contact the manufacturer to obtain replacement marking labels when necessary.

Projectile Hazards:

- Failure of the workpiece, of accessories or even of the tool itself can generate high-velocity projectiles.
- Always wear impact-resistant eye protection during the operation of the assembly power tool for threaded fasteners. The grade of protection required should be assessed for each use.
- Ensure that the workpiece is securely fixed.

Entanglement Hazards:

- Entanglement hazards can result in choking, scalping and/or lacerations if loose clothing, personal jewellery, neckware, hair or gloves are not kept away from the tool and accessories.
- Inappropriate gloves can become entangled with the rotating drive, causing severed or broken fingers.
- Rotating drive sockets and drive extensions can easily entangle rubber-coated or metal-reinforced gloves.
- Do not wear loose-fitting gloves or gloves with cut or frayed fingers.
- Never hold the drive, socket or drive extension.
- Keep hands away from rotating drives.

Operating Hazards:

- The use of the tool can expose the operator's hands to hazards including crushing, impacts, cuts, abrasions and heat. Wear suitable gloves to protect hands.
- These tools require the use of a suitable reaction which presents a crushing hazard. Ensure the set up instructions in this manual are followed.
- Operators and maintenance personnel shall be physically able to handle the bulk, weight and power of the tool.
- Hold the tool correctly; be ready to counteract normal or sudden movements and have both hands available.

- Maintain a balanced body position and secure footing.
- Release the trigger in the case of an interruption of the energy supply.
- Use only lubricants recommended by the manufacturer.
- Do not use in confined spaces and beware of crushing hands between tool and workpiece.

Repetitive Motions Hazards:

- When using a power tool for threaded fasteners, the operator can experience discomfort in the hands, arms, shoulders, neck, or other parts of the body.
- While using an assembly power tool for threaded fasteners, the operator should adopt a comfortable posture whilst maintaining secure footing and avoiding awkward or off-balanced postures. The operator should change posture during extended tasks, which can help avoid discomfort and fatigue.
- If the operator experiences symptoms such as persistent or recurring discomfort, pain, throbbing, aching, tingling, numbness, burning sensations or stiffness, these warning signs should not be ignored. The operator should tell the employer and consult a qualified health professional.

Accessory Hazards:

- Disconnect the assembly power tool for threaded fasteners from the energy supply before changing the tool or accessory.
- Use only sizes and types of accessories and consumables that are recommended by the assembly power tool for threaded fasteners manufacturer; do not use other types or sizes of accessories and consumables.

Workplace Hazards:

- Slips, trips and falls are major causes of workplace injury. Be aware of slippery surfaces caused by the use of the tool and also of trip hazards caused by the air line or hydraulic hose.
- Proceed with care in unfamiliar surroundings. Hidden hazards, such as electricity or other utility lines, can exist.
- The assembly power tool for threaded fasteners is not intended for use in potentially explosive atmospheres and is not insulated against coming into contact with electrical power.
- Make sure there are no electrical cables, gas pipes, etc., that can cause a hazard if damaged by use of the tool.

Dust and Fume Hazards:

- Dust and fumes generated when using assembly power tools for threaded fasteners can cause ill health (for example, cancer, birth defects, asthma and/or dermatitis); risk assessment and implementation of appropriate controls for these hazards are essential.
- Risk assessment should include dust created by the use of the tool and the potential for disturbing existing dust.
- Direct the exhaust to minimize disturbance of dust in a dust-filled environment.
- Where dust or fumes are created, the priority shall be to control them at the point of emission.
- All integral features or accessories for the collection, extraction or suppression of airborne dust or fumes should be correctly used and maintained in accordance with the manufacturer's instructions.
- Use respiratory protection in accordance with employer's instructions and as required by occupational health and safety regulations.

Noise Hazards:

- Unprotected exposure to high noise levels can cause permanent, disabling, hearing loss and other problems, such as tinnitus (ringing, buzzing, whistling or humming in the ears). Therefore a risk assessment and implementation of appropriate controls for these hazards are essential.
- Appropriate controls to reduce the risk may include actions such as damping materials to prevent workpieces from “ringing”.
- Use hearing protection in accordance with employer's instructions and as required by occupational health and safety regulations.
- Operate and maintain the assembly power tool for threaded fasteners as recommended in the operator's manual, to prevent an unnecessary increase in noise levels.
- If the assembly power tool for threaded fasteners has a silencer, always ensure it is in place and in good working order when the assembly power tool for threaded fasteners is operating.
- Select, maintain and replace the consumable/tool as recommended in the operator's manual, to prevent an unnecessary increase in noise.

Vibration Hazards:

- Exposure to vibration can cause disabling damage to the nerves and blood supply of the hands and arms.
- Wear warm clothing when working in cold conditions and keep your hands warm and dry.
- If you experience numbness, tingling, pain or whitening of the skin in your fingers or hands, stop using the assembly power tool for threaded fasteners, tell your employer and consult a physician.
- Operate and maintain the assembly power tool for threaded fasteners as recommended in the operator's manual, to prevent an unnecessary increase in vibration levels.
- Do not use worn or ill-fitting sockets or extensions, as this is likely to cause an increase in vibration.
- Select, maintain and replace the consumable/tool as recommended in the operator's manual, to prevent an unnecessary increase in vibration levels.
- Support the weight of the tool in a stand, tensioner or balancer, if possible.
- Hold the tool with a light but safe grip, taking account of the required hand reaction forces, because the risk from vibration is generally greater when the grip force is higher.

Additional Safety Instructions for Pneumatic Power Tools:



- Air under pressure can cause severe injury:
 - Always shut off air supply, drain hose of air pressure and disconnect tool from air supply when not in use, before changing accessories or when making repairs;
 - Never direct air at yourself or anyone else.
- Whipping hoses can cause severe injury. Always check for damaged or loose hoses and fittings.
- Cold air shall be directed away from the hands.
- Air lines with safe disconnect couplings, as supplied, are recommended. Whenever universal twist couplings (claw couplings) are used, lock pins shall be installed and whipcheck safety cables shall be used to safeguard against possible hose-to-tool and hose-to-hose connection failure.
- Do not exceed the maximum air pressure stated on the tool.

- For torque control and continuous rotation tools, the air pressure has a safety critical effect on performance. Therefore, requirements for length and diameter of the hose shall be specified.
- Never carry an air tool by the hose.

PTS™ Specific Safety Instructions:

- This tool is intended for use with threaded fasteners. Other uses within the limits of the tool may be appropriate. Please contact Norbar for guidance.
- The user (or the user’s employer) shall assess the specific risks that can be present as a result of each use. This Operator’s Manual contains sufficient information for the end user to be able to perform an initial risk assessment.
- Unexpected direction of drive square movement can cause a hazardous situation.
- Isolate the tool from all energy sources before changing or adjusting the drive square or socket.

Markings on Tool

Pictograms on Tool	Meaning
	<p>Read and understand Operator’s Manual.</p>
	<p>If a Reaction is purchased from Norbar it will include this label:</p> <p>Unexpected tool movement due to reaction forces or breakage of drive square or reaction bar may cause injuries. There is a risk of crushing between the reaction bar and workpiece. Keep hands away from reaction bar. Keep hands away from tool output.</p>

INTRODUCTION





The PneuTorque® PTS™ series are non-impacting, air driven power tools designed for applying torque to threaded fasteners. Remote control versions have no direction/shut-off control on the tool but rely on external pneumatic circuitry (not provided) to provide this function. This opens up numerous application possibilities for the PneuTorque® ranging from simple stall shut-off in a hazardous working environment to sophisticated, multi-spindle torque and angle shut-off systems.

Together with the external pneumatic circuitry an external pressure regulator (Lubro Control Unit) is needed; this allows the air pressure to be adjusted to determine the stall torque from the graph provided. There are models to cover torque capacities of 500 N·m to 7000 N·m.

The PTS™ must always be operated with the following:

- Filtered dry air supply. Minimum recommended compressor rating: 6.9 bar (100 psi), 19 l/s (40 CFM).
- Lubro Control Unit or similar Filter, Regulator and Lubricator Unit ½" Bore (12 mm).
- Impact or high quality sockets.

Parts Included

Description	Model:				
	PTS™-52	PTS™-72	PTS™-80	PTS™-92	PTS™-119
Visual Difference					
Reaction Bar Retaining Circlip	26588	26486	26486	26486	26482
Operator's Manual & language USB drive	34442	34442	34442	34442	34442



Explanation of Data Label:



FIGURE 1 – Data Label

- A: Norbar Serial Number (First 4 digits = Year of manufacture).
- B: Norbar Part Number, including reference to square drive size.
- C: Maximum calibrated Torque value.
- D: Maximum rated air pressure.
- E: Maximum free-running speed (achieved when tool is set to the air pressure for the max. torque value).
- F: Instruction to read operator's manual before use.

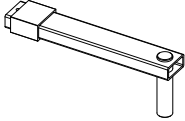
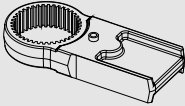
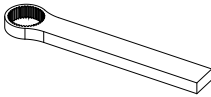
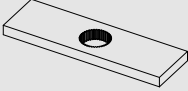
Accessories

Description	Part Number				
	PTS™-52	PTS™-72	PTS™-80	PTS™-92	PTS™-119
Lubro Control Unit	16074	16074	16074	16074	16074
¾" Drive Square (fixing screw)	18544 (25351.30)	18779 (25352.45)	-	-	-
1" Drive Square (fixing screw)	18545 (25351.30)	18492 (25352.45)	TBC	18934 (25352.60)	-
1 ½" Drive Square (fixing screw)	-	-	-	18935 (25352.60)	18959 (25352.80)
Reaction Bar [NOTE 1]					
	18298	18298	TBC	-	-
Reaction Adaptor [NOTE 1]					
	18558	18290	TBC	-	-
Single-Sided Reaction Plate					
	18576	18292	TBC	18979	16687
Double-Sided Reaction Plate					
	18590	18293	TBC	18980	18981
Weld Ring					
	18694	18695	18695	18696	18697
6" Blade Nose Extension	(¾") 18601.006	(1") 19007.006	TBC	-	-
9" Blade Nose Extension	(¾") 18601.009	(1") 19007.009	TBC	-	-
12" Blade Nose Extension	(¾") 18601.012	(1") 19007.012	TBC	-	-
6" Splined Nose Extension	(¾") 19045.006	(¾") 19046.006 (1") 19285.006	TBC	(1") 19047.006	-
9" Splined Nose Extension	(¾") 19045.009	(¾") 19046.009 (1") 19285.009	TBC	(1") 19047.009	-

Description	Part Number				
	PTS™-52	PTS™-72	PTS™-80	PTS™-92	PTS™-119
12" Splined Nose Extension	(³ / ₄ " 19045.012	(³ / ₄ " 19046.012 (1" 19285.012	TBC	(1" 19047.012	-
Lifting Handle 	-	19363	19363	19363	19363
Lightweight Aluminium Reaction 	-	18494	TBC	18936	18961 [NOTE 2]
Standard Steel Reaction 	18646	19289	19289	19291	19293
Twin Solenoid Valve 	60310	60310	60310	60310	60310
Tool Controller (TTT based) 	60244	60244	60244	60244	60244
Tool Controller (T-Box XL™ based) 	60302	60302	60302	60302	60302

NOTE 1: Requires both the 'Reaction Bar' and 'Reaction Adaptor' to be used together.

NOTE 2: Max. Torque 6000 N·m

FEATURES AND FUNCTIONS

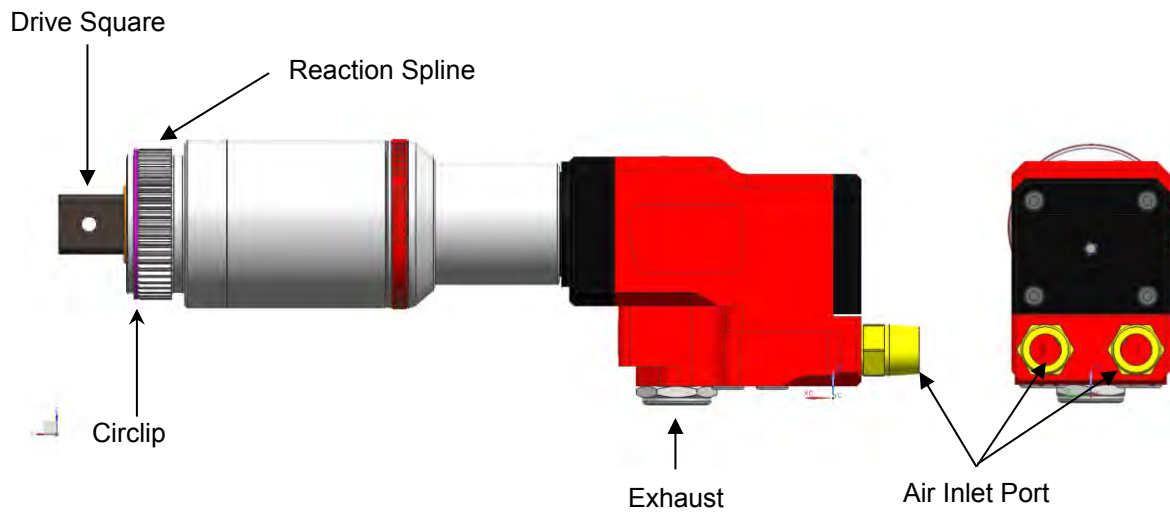

FIGURE 2 – Features

- A single efficient bi-directional air motor.
- Excellent power to weight ratio.
- $\pm 3\%$ repeatability. Accuracy better than $\pm 3\%$ (see calibration certificate).
- Very quiet operation reducing the need for protection with sound pressure level at 80.7 dB(A).
- Fast operation for rapid rundown. Up to 60% faster than PT-72 model.
- The splined reaction provides fast and safe fitment of a range of reactions.
- Replaceable square drive designed to shear, avoiding internal damage to the tool.
- Models covering 8 torque ranges from 500 N·m up to 7000 N·m.
- Wide range of compatible tool controllers and solenoid valves.
- Wide range of transducers available.
- Norbar's in-house 'Engineer-to-Order' team offer customised / integrated design solutions featuring the PTS™ Remote.

SET UP INSTRUCTIONS

1. Torque Reaction

The reaction plate is used to take the torque reaction force (which is equal and opposite to the tool output) and can also be used to mount the tool.



FIGURE 3 – Weld Ring



FIGURE 4 – Double-Sided Reaction Plate Option

NOTE: The remote control tools are not supplied with a reaction plate/bar as standard.

Norbar offer several types of reaction bar (like the double-sided reaction plate shown in Figure 4) and weld rings (figure 3) which allow users to integrate the reaction spline into their own custom reaction solutions.

Alternatively, contact Norbar's Engineer-to-Order team for a bespoke design and quotation for a reaction solution.

The conventional way to retain the tool within the reaction spline is via the circlip which locates in the groove at the front of the spline feature.

If using a conventional reaction bar: It is essential that the reaction plate rests squarely against a solid object or surface adjacent to the fastener to be tightened. The contact area must be within the shaded area of Figure 5, with the contact area as large as possible.

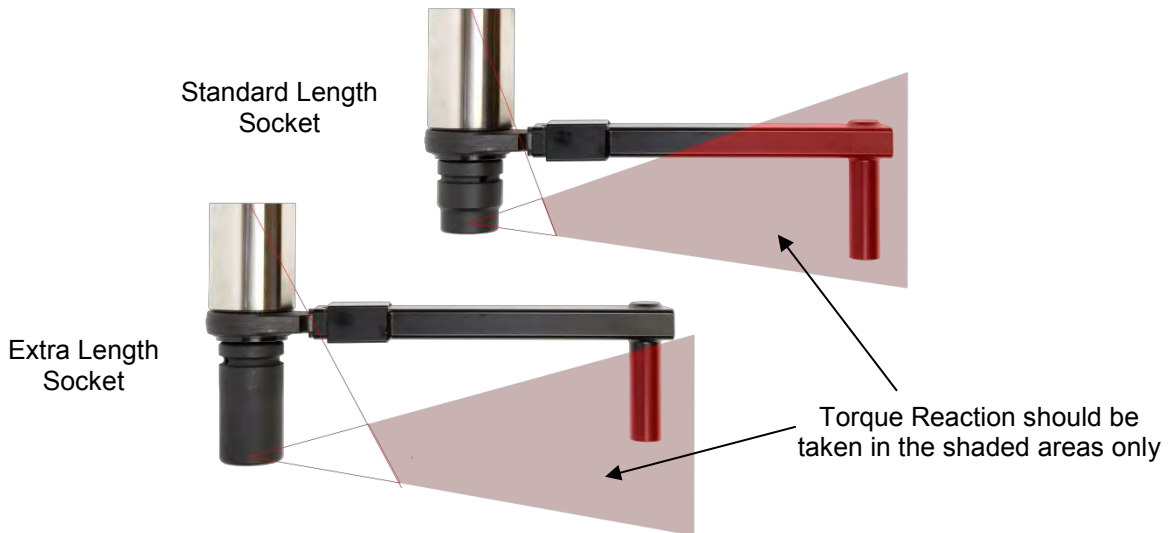

FIGURE 5 – Effect of Long Sockets



WARNING: CARE MUST BE TAKEN TO ENSURE THAT THE REACTION PLATE IS ONLY USED WITHIN THE LIMITATIONS SHOWN IN FIGURE 5.

For special applications or where extra length sockets must be used, the standard arm may be extended but only within the limitations shown on Figure 5.



WARNING: FAILURE TO OBSERVE THE LIMITATIONS SHOWN IN FIGURE 5 WHEN MODIFYING STANDARD REACTION PLATES MAY RESULT IN PREMATURE WEAR OR DAMAGE TO THE TOOL.

Standard drive square extensions **MUST NOT** be used as these will cause serious damage to the tool output drive. A range of nose extensions is available for applications where access is restricted. These are designed to support the final drive correctly.

When the PneuTorque® is in operation the reaction plate rotates in the opposite direction to the output drive square and must be allowed to rest squarely against a solid object or surface adjacent to the bolt to be tightened. (See Figure 6).



WARNING: ALWAYS KEEP HANDS CLEAR OF THE REACTION PLATE WHEN THE TOOL IS IN USE OR SERIOUS INJURY MAY RESULT.

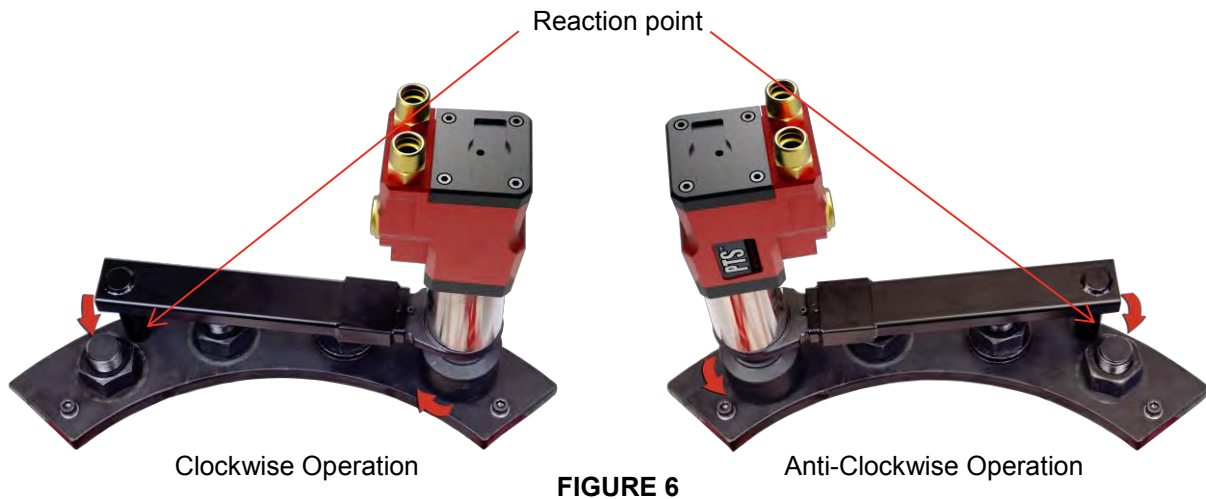

FIGURE 6

2. Air Lubrication

The tool must be used with oil lubrication in the supplied air. This is achieved by using a Lubro Control Unit (not supplied).

Set the air lubrication:

- a. Fill Lubro Control Unit with appropriate air-tool grade oil.
- b. Ensure the tool drive is free to rotate.
- c. Run the tool – adjust the tool to max pressure according to the setting data.
- d. Adjust Lubrication Unit to supply 4 drops of oil per minute.

See Lubro Control Unit Operator's Manual for more details.

3. Tool Control Systems

The remote control air motor requires a separate external pneumatic circuit (not supplied) for on/off and clockwise / anticlockwise control of the tool. The direction of tool rotation is determined by pressurising either the clockwise or anti-clockwise air inlet ports.

A Lubro Control Unit (Part Number 16074 - not supplied) is required to lubricate the air and control the air pressure so the correct torque is applied. Check the oil level in the Lubro Control Unit and fill to the correct level.

Ensure air hoses are clean and free from dirt before connecting. The air supply hoses and control valves must be ½" bore (12mm) and the hose from the supply to the control system must not be longer than 5 metres or the tools performance will be impaired. If the supply hose must be longer than 5 metres then ¾" bore must be used.

Examples of pneumatic control circuits are shown in Figures 7 and Figure 8.

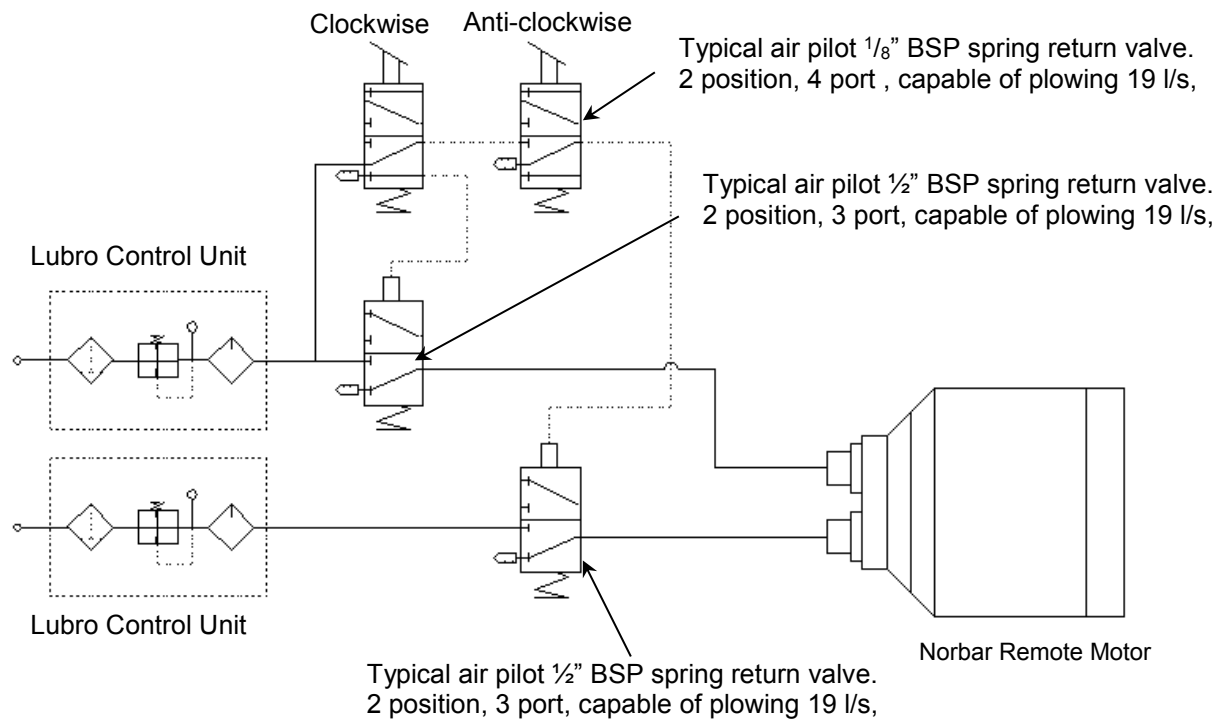

FIGURE 7 – Example of Pneumatic Circuit

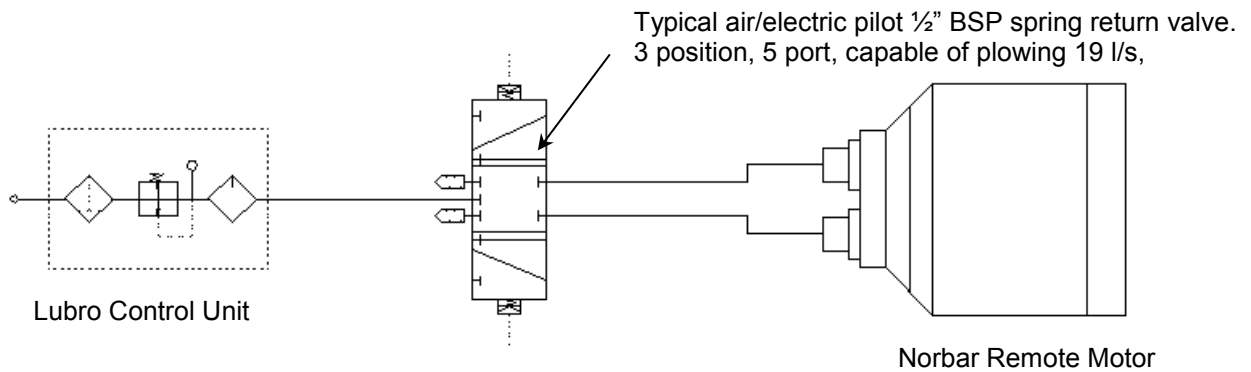

FIGURE 8 – Example of Pneumatic Circuit



WARNING: TO AVOID HAZARD FROM WHIPPING AIR HOSES MAKE ALL CONNECTIONS TO THE TOOL BEFORE TURNING ON THE AIR SUPPLY.

4. Input Ports

The input ports are located at the rear of the tool covered by plastic protection caps (# 16199). Connect the clockwise supply and anti-clockwise supply to the 1/2" BSP connectors as shown in Figure 9.

5. Exhaust Port

The exhaust port, located under the tool, is common to both inlet ports. If required an exhaust hose can be connected, this will reduce the sound pressure level. The exhaust hose size must not be reduced from 3/4" (19mm) or the tool performance will be reduced.

TIP: As with any pneumatic tool a fine oil mist is present in the exhaust air. Please ensure the exhaust air cannot cause a hazard.

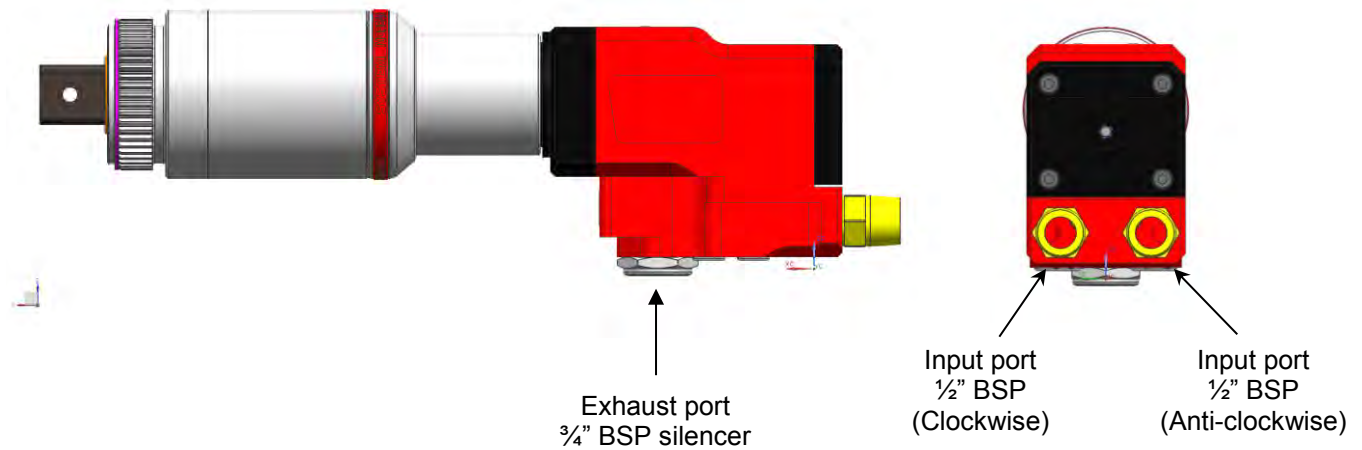

FIGURE 9 – Ports

6. Setting Torque to Tighten Fastener

The torque created by the PneuTorque® depends on the air pressure setting. All tools are supplied with setting data that gives the air pressure required to produce the correct torque output.

Set the torque output as follows:

- i) Use the setting data (supplied) to find the air pressure to achieve the required torque.

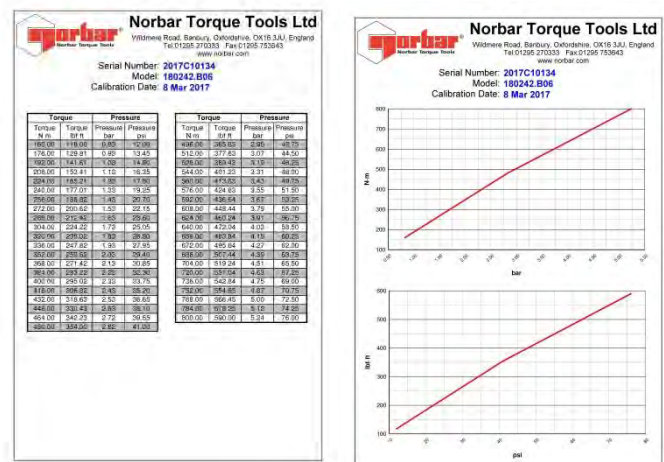

FIGURE 10 – Setting Data

- ii) With the tool running, adjust the Lubro Control Unit (not included) until the correct air pressure is shown on the gauge.

IMPORTANT: THE TOOL MUST BE FREE RUNNING WHILE ADJUSTING THE AIR PRESSURE TO GIVE THE CORRECT SETTING.

IMPORTANT: CHECK THAT THE LUBRO CONTROL UNIT IS SUPPLYING APPROXIMATELY FOUR DROPS OF OIL PER MINUTE WHILE THE TOOL IS FREE RUNNING.



FIGURE 11 – Lubro Control Unit

OPERATING INSTRUCTIONS



WARNING: KEEP HANDS CLEAR OF THE REACTION BAR AND DRIVE SOCKET.



WARNING: WHEN USING THIS TOOL IT MUST BE SUPPORTED AT ALL TIMES IN ORDER TO PREVENT UNEXPECTED RELEASE IN THE EVENT OF FASTENER OR COMPONENT FAILURE.



WARNING: CHANGING THE AIR PRESSURE AFTER SETTING THE PRESSURE REGULATOR WILL CHANGE THE STALL TORQUE VALUE.



WARNING: IF EQUIPMENT IS USED IN A MANNER NOT SPECIFIED BY THE MANUFACTURER, INJURY OR DAMAGE COULD RESULT.

Tightening

1. Fit PneuTorque® with the correct size impact or high quality socket.
2. Ensure the external control circuit is correctly set.
3. Fit the tool onto the fastener. Locate reaction bar adjacent to the reaction point.
4. Start the tool and allow it to continuously tighten the fastener. Full torque will only have been applied once the tool has stalled.
5. Stop tool and remove from fastener.

Releasing

1. Fit PneuTorque® with the correct size impact or high quality socket.
2. Ensure external control circuit is correctly set.
3. Fit the tool onto the fastener. Locate reaction bar adjacent to the reaction point.
4. Start the tool to release the fastener.

TIP: If unable to release the fastener, increase the air pressure to the tool. Do not exceed the maximum air pressure.

TIP: In the event that lubrication fails and / or contaminated air (e.g. water) enters the tool it is strongly recommended that the tool is free run on a clean, dry and lubricated air supply for several minutes.



WARNING: EXCEEDING THE MAXIMUM AIR PRESSURE WILL CAUSE OVERLOADING AND MAY LEAD TO SERIOUS DAMAGE.

5. Remove tool from fastener.

MAINTENANCE

For optimum performance and safety, regular tool maintenance is required. The user maintenance is limited to the replacement of the drive square and the silencers. Any other maintenance or repairs should be carried out by Norbar or a Norbar approved distributor. Maintenance intervals will depend on the tool usage and the environment in which it is being used:

- The maximum recommended service and recalibration interval is 12 months OR 10,000 cycles, whichever occurs first.
- If tool exhibits abnormal performance please contact your Norbar approved distributor.

TIP: Steps the user can take to reduce the amount of maintenance required include:

1. Use the tool in a clean environment.
2. Use an air compressor fitted with a dryer.
3. Ensure the Lubro Control Unit has sufficient air-tool grade oil.
4. Ensure the Lubro Control Unit delivers air-tool grade oil at the correct rate.
5. Ensure the Lubro Control Unit is regularly maintained, see product manual.
6. Maintain the correct torque reaction.
7. In the event that lubrication fails and / or contaminated air (e.g. water) enters the tool it is strongly recommended that the tool is free run on a clean, dry and lubricated air supply for several minutes.
8. Prior to long periods of storage it is strongly recommended that the tool is free run on a clean, dry and lubricated air supply for several minutes.



WARNING: GLOVES SHOULD BE WORN FOR MAINTENANCE TO AVOID CONTACT WITH GREASE AND OIL.

Air Lubrication

Use appropriate air-tool grade oil (for example Shell Tellus S2 V15).

Gearbox

The gearbox is not user-serviceable. For more information on gearbox servicing please contact Norbar or your Norbar approved distributor.

Silencer

The PTS™ Remote silencer (#28704) is intended to last the lifetime of the tool (under optimum operating conditions). However, in adverse operating conditions a replacement is recommended if the user experiences a loss of tool performance.

If silencer (#28704) needs replacing, simply unscrew exhaust port and refit with a new part.

Drive Square

To avoid internal damage (especially due to torque overload), the output drive square has been designed to shear first. This saves major internal damage and allows easy square removal. For drive square part numbers see page 8.



FIGURE 12 – Square Drive Replacement

To replace drive square:

1. Remove the air supply.
2. Support the tool.
3. Remove the screw, then remove drive square.
If the square has sheared it may be necessary to use pliers to remove the broken parts.
4. Fit new drive square.
5. Fit new screw and tighten between 4 N·m to 5 N·m (for PTS™-52) or 8 N·m to 9 N·m (for PTS™-72/80/92/119).
6. Connect air supply.

TIP: If the drive square fails continually then seek advice from Norbar or a Norbar approved distributor.

Calibration

To maintain the PneuTorque® accuracy it is recommended the tool is recalibrated every 10,000 cycles or annually, whichever comes first. Contact Norbar or a Norbar distributor for more information.

Cleaning

Keep the tool in a clean condition to aid safety. Do not use abrasives or solvent based cleaners.

Disposal

Recycling Considerations: Please recycle where possible.
The tool has no hazardous disposal requirements.

SPECIFICATIONS

Part Number	Model	Square Drive	Torque		Output Speed
			Minimum	Maximum	
180271.B06	PTS™-52-500	¾"	100 N·m (74 lbf·ft)	500 N·m (370 lbf·ft)	27.8 rev/min
180272.B06	PTS™-52-800	¾"	160 N·m (118 lbf·ft)	800 N·m (590 lbf·ft)	20.1 rev/min
180273.B06	PTS™-72-1000	¾"	200 N·m (147 lbf·ft)	1000 N·m (738 lbf·ft)	16.0 rev/min
180274.B08	PTS™-72-1350	1"	270 N·m (200 lbf·ft)	1350 N·m (1000 lbf·ft)	11.5 rev/min
180275.B08	PTS™-72-2000	1"	400 N·m (295 lbf·ft)	2000 N·m (1475 lbf·ft)	7.2 rev/min
180276.B08	PTS™-80-2700	1"	540 N·m (400 lbf·ft)	2700 N·m (2000 lbf·ft)	5.7 rev/min
180277.B08	PTS™-92-4000	1"	800 N·m (590 lbf·ft)	4000 N·m (2950 lbf·ft)	4.1 rev/min
180277.B12	PTS™-92-4000	1 ½"	800 N·m (590 lbf·ft)	4000 N·m (2950 lbf·ft)	4.1 rev/min
180279.B12	PTS™-119-7000	1 ½"	1400 N·m (1030 lbf·ft)	7000 N·m (5200 lbf·ft)	2.1 rev/min

Part Number	Model	Dimensions (mm)					Tool Weight Without Reaction (kg)
		L	W	ØD	H1	H2	
180271.B06	PTS™-52-500	284	70	Ø52	29	77.5	4.1
180272.B06	PTS™-52-800	284	70	Ø52	29	77.5	4.1
180273.B06	PTS™-72-1000	311	70	Ø72	29	77.5	6.14
180274.B08	PTS™-72-1350	311	70	Ø72	29	77.5	6.14
180275.B08	PTS™-72-2000	344	70	Ø72	29	77.5	6.5
180276.B08	PTS™-80-2700	311	70	Ø80	29	77.5	6.05
180277.B08	PTS™-92-4000	362	70	Ø92	29	77.5	8.85
180277.B12	PTS™-92-4000	362	70	Ø92	29	77.5	8.85
180279.B12	PTS™-119-7000	385	70	Ø119	29	77.5	12.42

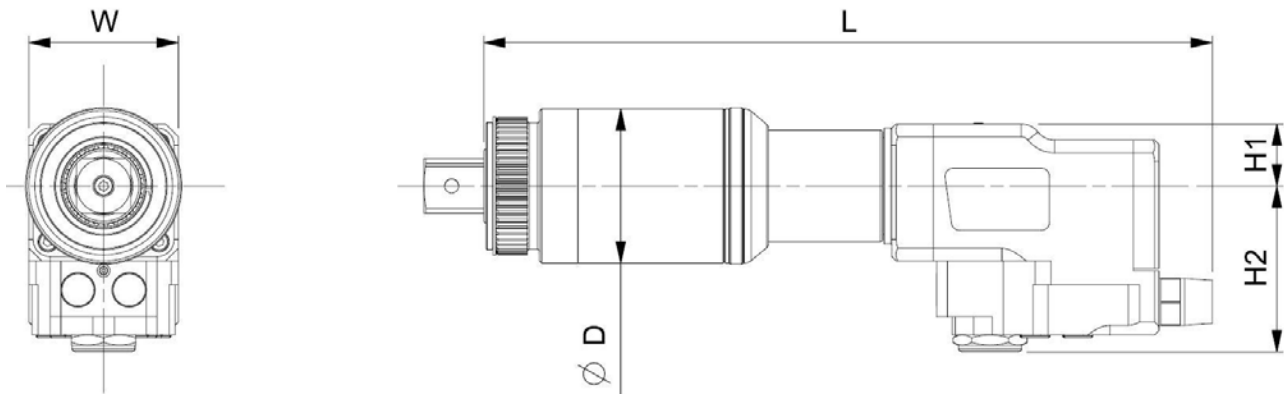

FIGURE 13 – Dimensions

Repeatability:	±3%
Accuracy:	Accuracy better than ±3% (see calibration certificate)
Operating Range:	20% to 100% of tool capacity
Air Consumption:	16.5 l/s (35 CFM)
Temperature Range:	0°C to +50°C (operating). -20°C to +60°C (storage).
Operating Humidity:	85% Relative Humidity @30°C maximum.
Handle Vibration:	< 2.5m/s ² measured in accordance with ISO 28927-2.
Sound Pressure Level:	The sound pressure level is 80.7* dB(A) uncertainty K = 3dB, measured in accordance with BS EN ISO 11148-6 <i>*Tool tested: PTS™-4000 at 75 PSI</i>
Environment:	Store and use in a clean & dry environment.

Due to continuous improvement all specifications are subject to change without prior notice.

NOTE: If equipment is used in a manner not specified by the manufacturer, the protection provided by the equipment could be impaired.



Norbar Torque Tools Ltd
 Wildmere Road | Banbury | Oxfordshire | OX16 3JU | UK
 T +44 (0)1295 270333 | F +44 (0)1295 753643
 E enquiry@norbar.com | www.norbar.com

QA57
 ISSUE 2
 24.1.97

EU Declaration of Incorporation (No 0017)

This declaration of conformity is issued under the sole responsibility of the manufacturer.

The object of the declaration:

PneuTorque® PTS™ Remote tools.

- Model Names (Part Numbers):
 PTS™.52-500 (180271.B06)
 PTS™.52-800 (180272.B06)
 PTS™.72-1000 (180273.B06)
 PTS™.72-1350 (180274.B08)
 PTS™.72-2000 (180275.B08)
 PTS™.80-2700 (180276.B08)
 PTS™.92-4000 (180277.B08)
 PTS™.92-4000 (180277.B12)
 PTS™.119-7000 (180279.B12)



The object of the declaration described above is in conformity with the relevant union harmonisation legislation:
 Directive 2006/42/EC on Machinery.

The object of the declaration described above has been designed to comply with the following standards:

BS EN ISO 12100:2010	Safety of machinery. General principles for design. Risk assessment and risk reduction.
----------------------	---

The basis on which conformity is being declared:

This declaration is issued under the sole responsibility of the manufacturer. The technical documentation required to demonstrate that the products meet the requirements of the above directives has been compiled by the signatory below and is available for inspection by the relevant enforcement authorities.

The machine must not be put into service until the machine into which it is to be incorporated has been deemed to conform to the applicable directives.

Signed for and on behalf of Norbar Torque Tools Ltd.

Signed: *T.M. Lester* Full Name: Trevor Mark Lester B.Eng.
 Date: 20th November 2017. Authority: Compliance Engineer.
 Place: Norbar Torque Tools Ltd., Wildmere Road, Banbury, Oxfordshire. OX16 3JU.

United Kingdom | Australia | United States of America
 Singapore | China | India



Registered in England No: 380480 | VAT No GB 119 1060 05

TROUBLE SHOOTING

The following is only a guide, for more complex faults please contact your local Norbar distributor or Norbar directly.

Problem	Likely Solutions
Tool output does not rotate when control system operated	<ul style="list-style-type: none"> Check air supply is functioning & connected Check air pressure setting (at least 1 bar) Check correct setting of control system Output drive square sheared, needs replacing Gear train or air motor is damaged
Drive square sheared	See maintenance section to replace
Tool does not stall	<ul style="list-style-type: none"> Tool has not achieved torque, increase air pressure Fastener sheared or thread stripped Gear train or air motor is damaged
Free running speed becomes impaired	Silencers are blocked / need replacing

GLOSSARY OF TERMS

Word or Term	Meaning
Air pressure setting	Graph and or table supplied with all stall tools to show the air pressure setting to produce required torque
Bi-directional	Tool capable of Clockwise and Counter-clockwise square rotation
Fastener	Bolt or stud to be tightened
Lubro Control Unit	Unit to provide filtering and lubrication along with pressure regulation. Not supplied with tool
Nose Extension	A reaction type used where tool access is restricted, typical examples on wheel nuts on heavy vehicles. Available as an accessory
PneuTorque®	Product name
PTS™	PneuTorque® Single-Motor
Reaction Bar	Item to counteract applied torque. Also called reaction plate
Stall Tool	Tool will stall due to air pressure set
TBC	To be confirmed
Twist coupling / Claw coupling	A type of air connector. Not recommended by Norbar

**NORBAR TORQUE TOOLS LTD**

Wildmere Road, Banbury,
Oxfordshire, OX16 3JU
UNITED KINGDOM
Tel + 44 (0)1295 270333
Email enquiry@norbar.com

**NORBAR TORQUE TOOLS PTE LTD**

194 Pandan Loop
#07-20 Pantech Business Hub
SINGAPORE 128383
Tel + 65 6841 1371
Email enquires@norbar.sg

**NORBAR TORQUE TOOLS**

45-47 Raglan Avenue, Edwardstown,
SA 5039
AUSTRALIA
Tel + 61 (0)8 8292 9777
Email enquiry@norbar.com.au

**NORBAR TORQUE TOOLS (SHANGHAI) LTD**

91 Building-7F, No.1122 North Qinzhou Rd,
Xuhui District, Shanghai
CHINA 201103
Tel + 86 21 6145 0368
Email sales@norbar.com.cn

**NORBAR TORQUE TOOLS INC**

36400 Biltmore Place, Willoughby,
Ohio, 44094
USA
Tel + 1 866 667 2279
Email inquiry@norbar.us

**NORBAR TORQUE TOOLS INDIA PVT. LTD**

Plot No A-168, Khairne Industrial Area,
Thane Belapur Road, Mahape,
Navi Mumbai – 400 709
INDIA
Tel + 91 22 2778 8480
Email enquiry@norbar.in

www.norbar.com