



Ultra Yassı Mekanik Tork Artırıcılar

Ultra Flat Type Mechanical Torque Multipliers



- » Aktarım oranı 5:1, torklama hassasiyeti $\pm\%4$.
- » İnce tasarım, küçük hacim, ergonomik tasarım.
- » Dayanıklı, uzun ömürlü, minimum bakım ihtiyacı.
- » Tek kademe şanzıman, sıkma ve sökmeye uygun.
- » 1.000, 1.300 ve 2.700 N.m kapasitede 3 farklı model.
- » Geri dönüş kilit mekanizması yoktur.
- » İki farklı destek ayağıyla çanta içinde sevk edilir.

- » 1.000, 1.300 and 2.700 N.m three different models
- » 5:1 Torque multiplication, accuracy guaranteed better than $\pm\%4$.
- » Supplied with two reaction bar styles for maximum versatility.
- » No anti wind up ratchet (AWUR) mechanism.
- » Robust construction means minimal maintenance and long life.
- » Supplied in a carrying case, ideal for inclusion in the heavy vehicle tool kit.

1.000 N.m



180260

1.300 N.m

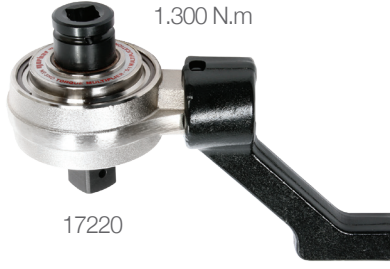

17220

2.700 N.m



17221

Parça Part	Tork Kapasitesi Torque Capacity		Aktarım Oranı Multiplication	Torkmetre Girişi Torque Square		Ağırlık Weight	D	H1	H2	L	R1	R2 min	R2 max	R3 max
No.	N.m	lbf.ft	#	inç	inç	kg	mm							
180260	100 - 1.000	74 - 740	5:1	1/2"	3/4"	2.7	65	63	21	273	55	83	143	240
17220	130 - 1.300	96 - 960	5:1	1/2"	3/4"	3.8	108	103	44	398	77	140	212	344
17221	270 - 2.700	200 - 2.000	5:1	3/4"	1"	3.8	108	100	36	398	85	140	212	344

Destek ayağı ağırlığı dahil değildir. / Weight without reaction arm.

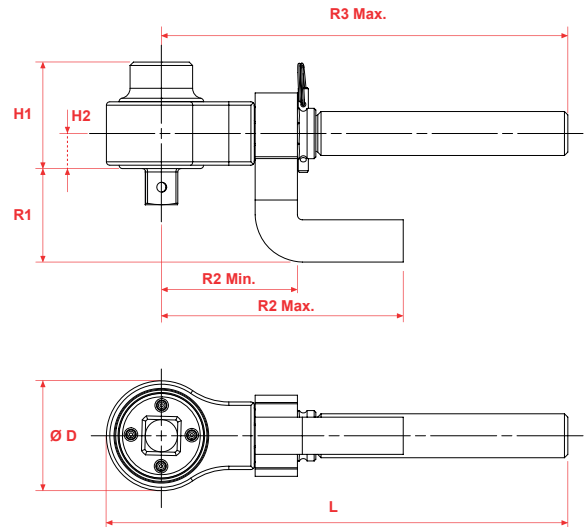
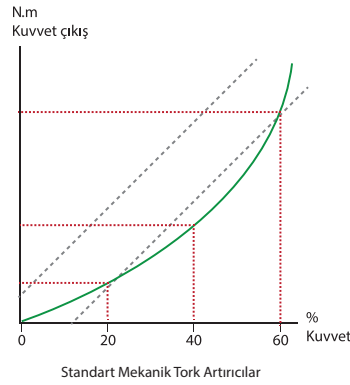
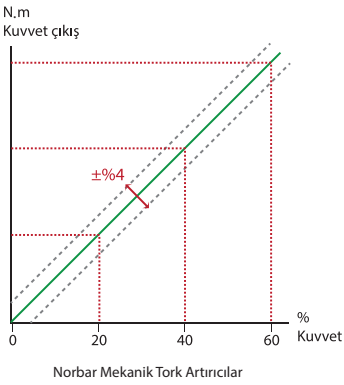

HT3 180260
HT3 17220
HT3 17221

1.000 N.m için kullanılması gereken tork anahtarı maksimum **200 N.m**
1.300 N.m için kullanılması gereken tork anahtarı maksimum **260 N.m**
2.700 N.m için kullanılması gereken tork anahtarı maksimum **540 N.m**