



SL0 Serisi Değişken Uçlu Tork Anahtarları

SL0 Series Torque Handles



Ø16 mm Spigot



9x12 mm Rectangular



- » ±%3 yüksek hassasiyetle torklama işlemi.
- » 4 ile 20 N.m arasında 3 farklı tork anahtarı.
- » Spigot ve dikdörtgen girişli değişken uç sistemi.
- » Yüzlerce çeşit açık ağız, yıldız ve çircir uç seçeneği.
- » N.m ve lbf.in. ikili hassas tip göstere paneli.
- » Ergonomik tutma kolu ile kolay kilitlenebilir mekanizma.
- » Tork erişimi kullanıcı tarafından rahatça hissedilir.

- » Accurate to ±%3 of reading which meets and exceeds ISO6789.
- » 3 different torque wrenches from 1 to 20 N.m.
- » Precision-adjusted display with dual scale.
- » 16 mm spigot and 9x12 mm female torque handles.
- » Prevents accidental adjustment of the set torque.
- » Unmistakable signal when set torque is reached.
- » Moulded grip aids correct hand location and operator comfort.

Parça Part	Tork Aralığı Torque Range		Hassasiyet Accuracy	Ölçek Increment		Uç Girişi Input Type	Ağırlık Weight	A	B	C	D	E
No.	N.m	lbf.in	%	N.m	lbf.in	#	kg	mm				
11036	1-20	10-180	± 3	1	10	Ø16 mm Spigot	0.4	206	199	143	16	-
11126	4-20	40-180	± 3	1	10	Ø16 mm Spigot	0.4	206	199	143	16	-
11122	4-20	40-180	± 3	1	10	9x12 mm	0.4	205	194	135	22	20

Ø16 mm Spigot Yuvarlak Girişli Uçlar / Ø16 mm Spigot End Fittings

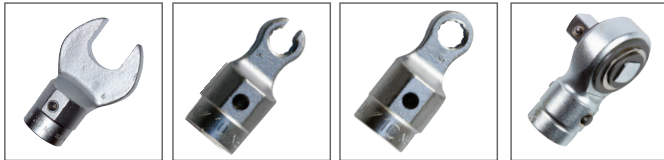

9x12 mm Dikdörtgen Girişli Uçlar / 9x12 mm Rectangular End Fittings

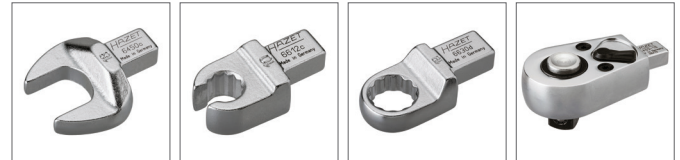

11036, 11126

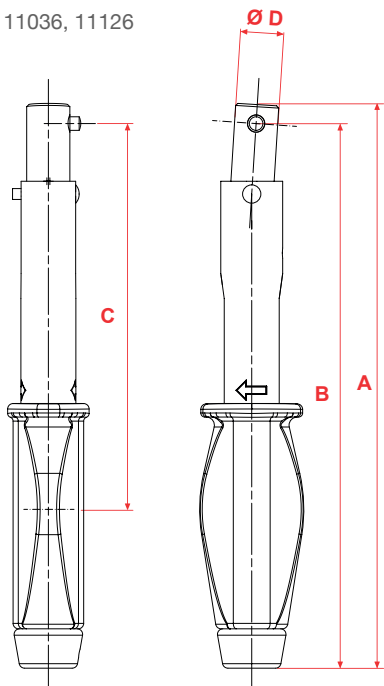

11122

