



Mini Tip Mekanik Çektirme Seti

Mini Type Mechanical Puller Kit



Genel Kullanım Talimatı:

- » Çektirmenin vidalı milini temiz tutunuz. Belli aralıklarla mili gresleyiniz.
- » Mil ucunu kasnağın merkezindeki deliğe kaymayacak şekilde oturtunuz.
- » Çektirme çenelerinin dengeli ve eşit olarak yerleştiriniz
- » Ana mili uygun anahtar ile çevirerek çektirme işlemini başlatınız
- » Mili çevirmek için havalı veya elektrikli alet kullanmayınız
- » Vidalı çektirme miline çekiçle asla vurmayınız.
- » Çektirme işlemi yaparken koruyucu ekipmanlarınızı kullanınız.

General Use Instructions:

- » Make sure the spindle is cleaned and greased before use.
- » Make sure the axle has a centre hole. If not use a point protector.
- » Make sure the jaws are evenly spread.
- » Apply pulling force by turning the spindle.
- » Never hit the spindle and not use power impact wrench.
- » Do not keep the spindle too sticking out from the puller's body.
- » Always wear suitable personal protective equipment.

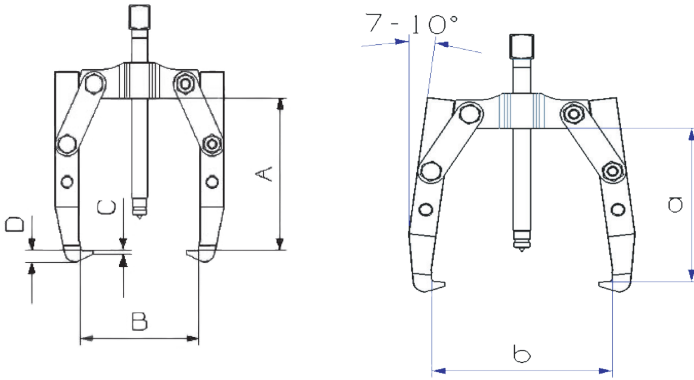

2 Kollu Kullanım 2 Jaws Application		A	B	a	b	C	D	Kapasite Capacity	Ağırlık Weight
#		mm	mm	mm	mm	mm	mm	Ton	kg
9300		60	40	40	54	1.5	4.5	0.5	0.2
9301		88	53	56	76	2.5	6	1	0.4



3 Kollu Kullanım 3 Jaws Application		A	B	a	b	C	D	Kapasite Capacity	Ağırlık Weight
#		mm	mm	mm	mm	mm	mm	Ton	kg
9300T		85	100	40	54	2.5	6	0.5	0.4
9301T		85	100	56	76	2.5	6	1	0.7



Çektirme seti yalnızca el anahtarı ile kullanılmalıdır. Çekiç ya da havalı-elektrikli sıkma-sökme tabancaları kullanılmamalıdır.
The puller kit should only be used with the hand wrench. Hammer or air-electric tools should not be used.

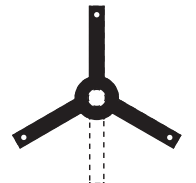
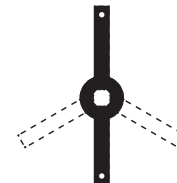
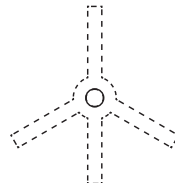
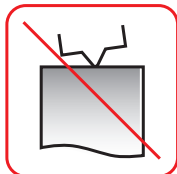

Taşyıcı Travers

2 Kollu Kullanım

3 Kollu Kullanım