



Mini Tip Mekanik Çektirme Seti

Mini Type Mechanical Puller Kit



Ürün Kodu: FMK100

- » 2 kollu kısa tip çekirtme
- » 2 kollu uzun tip çekirtme
- » 3 kollu kısa tip çekirtme
- » 3 kollu uzun tip çekirtme

Product Code: FMK100

- » 2 jaws short type puller
- » 2 jaws long type puller
- » 3 jaws short type puller
- » 3 jaws long type puller

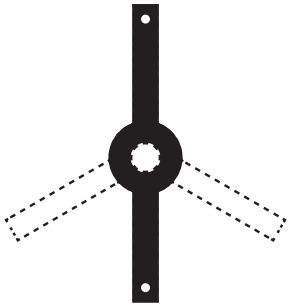

2 Kollu Kullanım

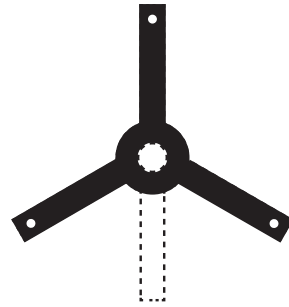

3 Kollu Kullanım

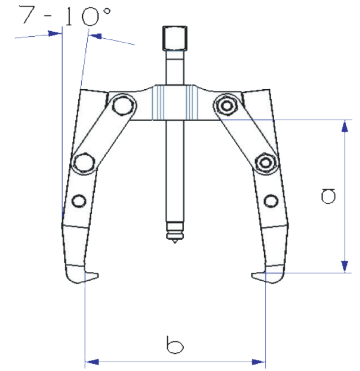
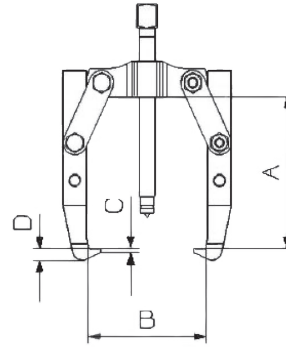

| 2 Kollu Kullanım 2 Jaws Application | A | B | a | b | C | D | Kapasite Capacity | Ağırlık Weight |
|--|----|----|----|----|-----|-----|----------------------|-------------------|
| # | mm | mm | mm | mm | mm | mm | Ton | kg |
| 9300 | 60 | 40 | 40 | 54 | 1.5 | 4.5 | 0.5 | 0.2 |
| 9301 | 88 | 53 | 56 | 76 | 2.5 | 6 | 1 | 0.4 |

| 3 Kollu Kullanım 3 Jaws Application | A | B | a | b | C | D | Kapasite Capacity | Ağırlık Weight |
|--|----|-----|----|----|-----|----|----------------------|-------------------|
| # | mm | mm | mm | mm | mm | mm | Ton | kg |
| 9300T | 85 | 100 | 40 | 54 | 2.5 | 6 | 0.5 | 0.4 |
| 9301T | 85 | 100 | 56 | 76 | 2.5 | 6 | 1 | 0.7 |

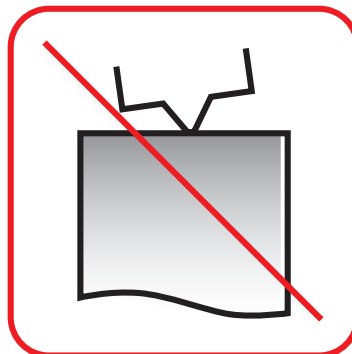



Mini Tip Mekanik Çektirme Seti

Mini Type Mechanical Puller Kit



Genel Kullanım Talimatı:

- » Çektirmenin vidalı milini temiz tutunuz. Belli aralıklarla mili gresleyiniz.
- » Mil ucunu kasnağın merkezindeki deliğe kaymayacak şekilde oturtunuz.
- » Çektirme çenelerinin dengeli ve eşit olarak yerleştiriniz
- » Ana mili uygun anahtar ile çevirerek çektirme işlemini başlatınız
- » Mili çevirmek için havalı veya elektrikli alet kullanmayınız
- » Vidalı çektirme miline çekiçle asla vurmayınız.
- » Çektirme işlemi yaparken koruyucu ekipmanlarınızı kullanınız.

General Use Instructions:

- » Make sure the spindle is cleaned and greased before use.
- » Make sure the axle has a centre hole. If not use a point protector.
- » Make sure the jaws are evenly spread.
- » Apply pulling force by turning the spindle.
- » Never hit the spindle and not use power impact wrench.
- » Do not keep the spindle too sticking out from the puller's body.
- » Always wear suitable personal protective equipment.

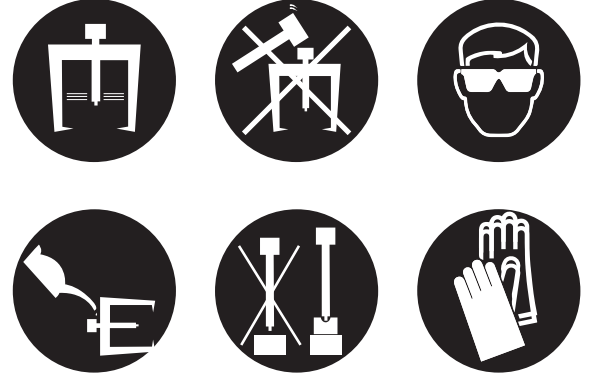
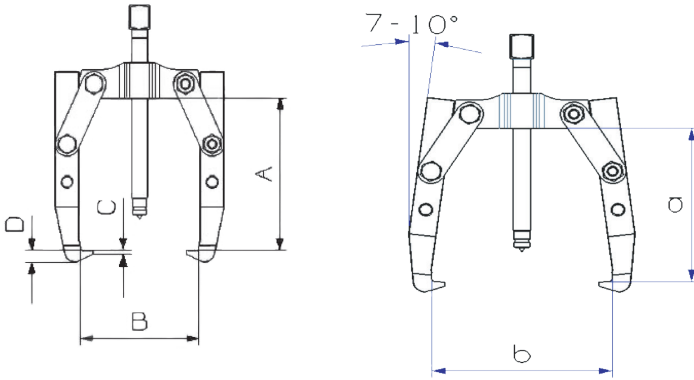

| 2 Kollu Kullanım 2 Jaws Application | | A | B | a | b | C | D | Kapasite Capacity | Ağırlık Weight |
|--|--|----|----|----|----|-----|-----|----------------------|-------------------|
| # | | mm | mm | mm | mm | mm | mm | Ton | kg |
| 9300 | | 60 | 40 | 40 | 54 | 1.5 | 4.5 | 0.5 | 0.2 |
| 9301 | | 88 | 53 | 56 | 76 | 2.5 | 6 | 1 | 0.4 |



| 3 Kollu Kullanım 3 Jaws Application | | A | B | a | b | C | D | Kapasite Capacity | Ağırlık Weight |
|--|--|----|-----|----|----|-----|----|----------------------|-------------------|
| # | | mm | mm | mm | mm | mm | mm | Ton | kg |
| 9300T | | 85 | 100 | 40 | 54 | 2.5 | 6 | 0.5 | 0.4 |
| 9301T | | 85 | 100 | 56 | 76 | 2.5 | 6 | 1 | 0.7 |



Çektirme seti yalnızca el anahtarı ile kullanılmalıdır. Çekiç ya da havalı-elektrikli sıkma-sökme tabancaları kullanılmamalıdır.
The puller kit should only be used with the hand wrench. Hammer or air-electric tools should not be used.

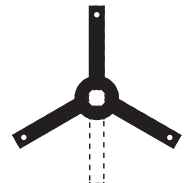
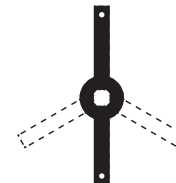
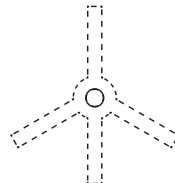
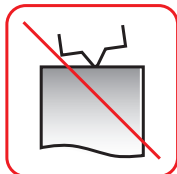

Taşyıcı Travers

2 Kollu Kullanım

3 Kollu Kullanım