



15 Ton Hidrolik Rüzgar Türbin Hizalama Ekipmanı

15 Ton Wind Turbine Tower Hydraulic Flange Alignment Tool



- » Türbin hizalama kapasitesi 15 Ton.
- » Flaş saplama deliklerinden kavrar ve hizalar.
- » Minimum 45 mm saplama deliğine uygundur.
- » Rüzgar türbin kule hizalaması için tasarlanmıştır.
- » Rüzgar türbin montajını hızlandırır.
- » 65 mm'ye kadar olan kaymaları düzeltir.
- » Dahili hidrolik el pompası ile kullanılır.
- » Siemens Wind Power tarafından onaylıdır.

- » Compact light-weight design.
- » 15T (150kN) flange alignment force.
- » Hydraulic pump included in the system.
- » Safe, cost effective, time-saving, simple operation.
- » Suitable for minimum 45 mm stud hole.
- » Aligning range up to 65 mm.
- » Approved by Siemens Wind Power.

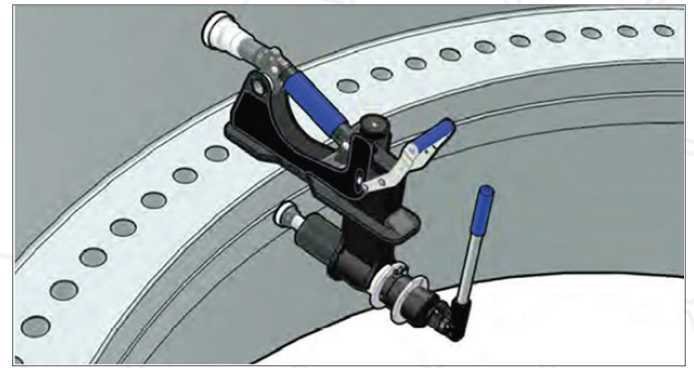
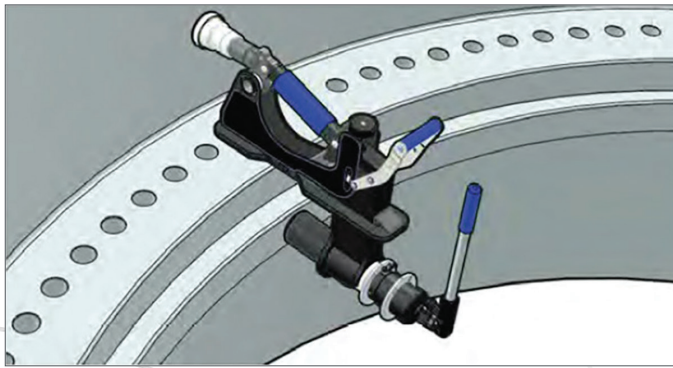
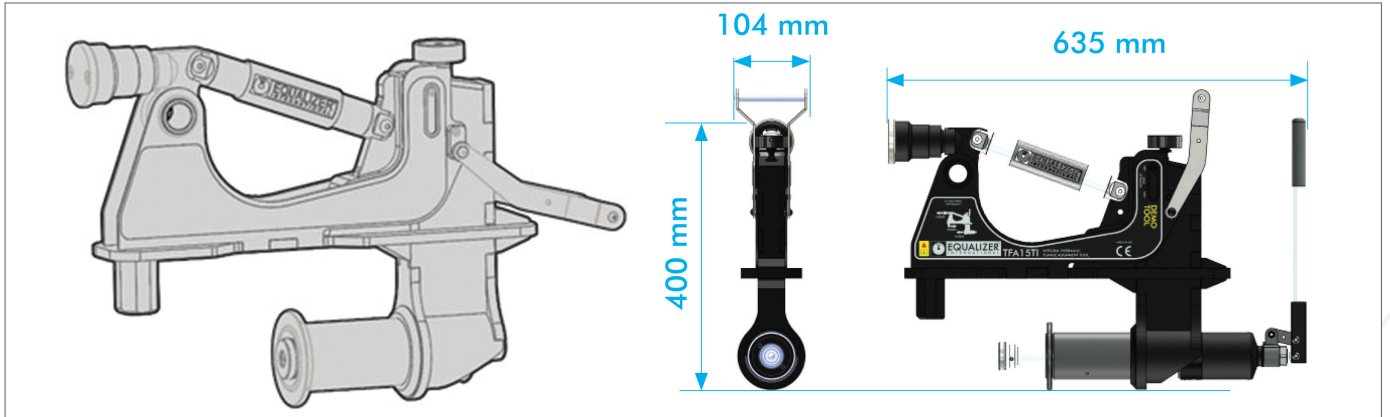

Sevkiyat İçeriği

Plastik çanta içinde
1 x TFA15TI flaş hizalayıcı
1 x Kullanma kılavuzu

Delivery Content

Plastic carry case
1 x TFA15TI flange alignment tool
1 x Instruction manual

Ağırlık ve Ölçüler

Cihaz ağırlığı : 21.5 Kg
Çantalı ağırlık : 30.5 Kg
Çanta ölçüsü : 585 x 900 x 170 mm

Sizes

Tool Weight : 21.5 Kg
With Box Weight : 30.5 Kg
Box Dimensions : 585 x 900 x 170 mm

