

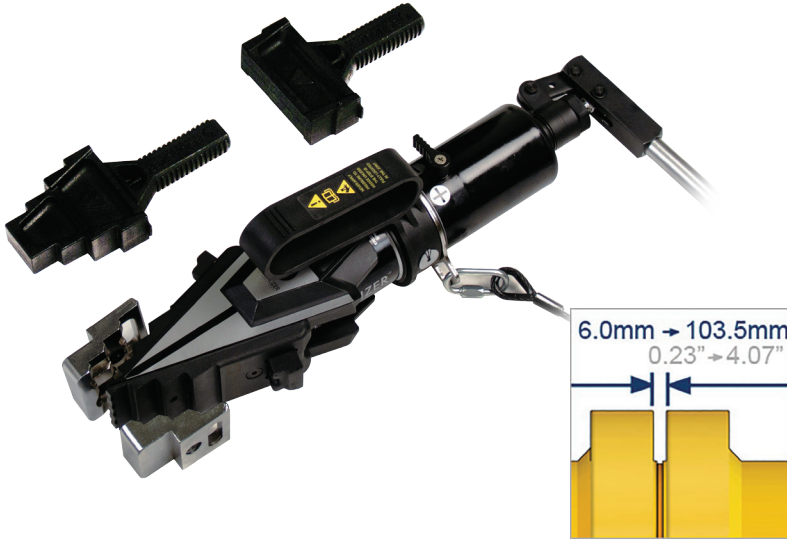

## 25 Ton Dahili Pompalı Hidrolik Flanş Ayırma Ekipmanı

### 25 Ton Hydraulic Flange Spreader with Integrated Pump



- » İlk basamakta flanş ayırma kapasitesi 20 ton.
- » 4. basamakta flanş ayırma kapasitesi 25 ton.
- » 6 mm boşluktan itibaren ayırma işlemini gerçekleştirir.
- » Maksimum 103.5 mm'ye kadar ayırma yapar.
- » 360° dönebilen ergonomik taşıma kolu.
- » Uygunsuz şartlarda sökülebilir seyyar kol.
- » Yatay ve dikey konumda çalışmaya uygun.
- » Tüm flanş çeşitlerine uygun tasarım ve yapı.

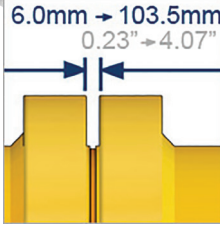

- » Revolving handle to aid horizontal or vertical spreading.
- » Offset handle is directly over the centre of mass.
- » Removable handle for improved access.
- » Revolving lanyard connection point.
- » No pinch-points, secure hold on each step.
- » Safety lanyard - 1.0m (39") length.
- » Forged key components for strength & reliability.

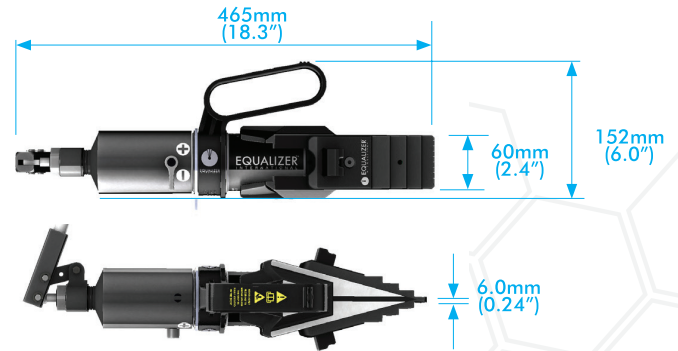
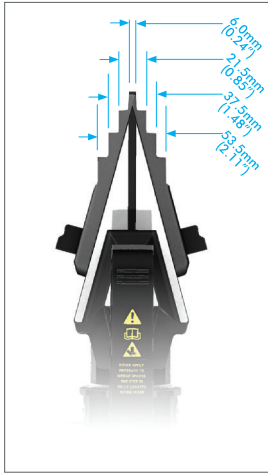

#### Sevkiyat İçeriği

- Plastik Çanta içinde
- 1 x SWi20/25TI flanş ayırıcı
- 1 x Dahili hidrolik pompa
- 2 x Güvenlik takozu
- 2 x İlerleme basamağı
- 1 x Güvenlik halatı
- 1 x Alyan anahtar
- 1 x Kullanma kılavuzu

#### Delivery Content

- Plastic carry case
- 1 x SWi20/25TI flange spreader
- 1 x 700 bar integral hydraulic pump
- 1 x Set of safety blocks
- 1 x Pair of stepped blocks
- 1 x Lanyard 1 x Hex key
- 1 x Carry-Strap
- 1 x Instruction manual

#### Ağırlık ve Ölçüler

- Cihaz ağırlığı : 6 Kg
- Çantalı ağırlık : 13.8 Kg
- Çanta ölçüsü : 580 x 330 x 165 mm

#### Sizes

- Tool Weight : 6 Kg
- With Box Weight : 13.8 Kg
- Box Dimensions : 580 x 330 x 165 mm

