

SPXFLOW Flanş Tip Hidrolik Somun Kesiciler

»Bolting Systems™ Hydraulic Nut Splitters with External Pump



- » Metrik ölçü: M20 - M90, somun anahtar ağız AF 30mm - 130mm.
- » İnç ölçü: , somun anahtar ağız AF 1¼" - 5. 3/8".
- » Kesici bıçaklar üç kenarlıdır, her kenar ayrı ayrı kullanılabilir.
- » Tek etkili yay geri dönüşlü veya çift etkili hidrolik sistem seçeneği.
- » Çift etkili hidrolik silindire su altı (subsea) işlemlerinde kullanılabilir.
- » ANSI, ASME B.16.5 tip flanşlara uygun olarak üretilmiştir.
- » API tip flanş bağlantıları için üretici firma ile temas kurulmalıdır.
- » Kesme derinliği sabittir ancak farklı somun ölçülerine ayarlanabilir.
- » Dahili emniyet valfi ile maksimum iş güvenliği sağlanır.
- » Garanti ve servis hizmetleri Surkon tarafından karşılanır.

- » Metric size bolt diameter: M20 - M90, Nut A/F : 30 mm - 130 mm.
- » Inch size bolt diameter: ¾" - 3½", Nut A/F : 1¼" - 5. 3/8".
- » Designed to fit AN E B.16.5 flanges.
- » Versatile, reliable and trouble-free operations.
- » Blade positioning scale to eliminate bolt damage.
- » Built-in safety relief valve to protect tool & operator.
- » Twin line hydraulic version available for subsea use.
- » Operates off a standard 10,000 psi (700 bar) pump unit.
- » Will work with some API flanges – contact factory for details.
- » Cutting depth fixed - Nut size adjustable via rotating cylinder!

Our hydraulic nut splitter offers a reliable and effective solution to the removal of seized and corroded nuts.

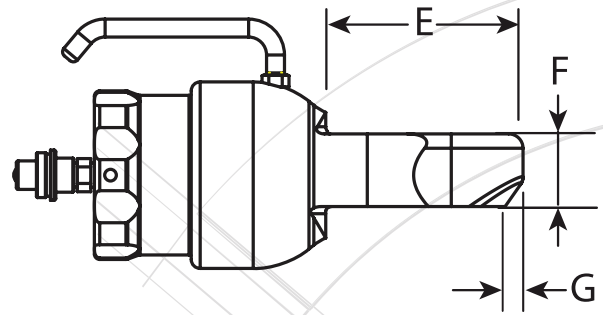
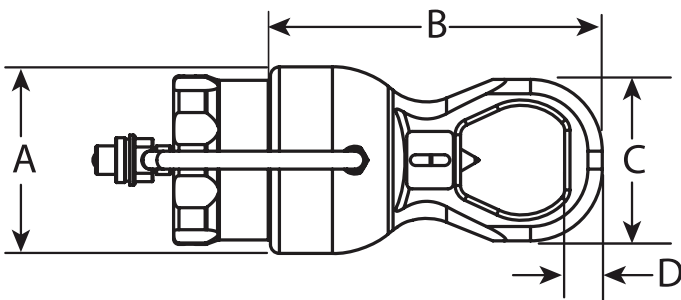

SPXFLOW Flanş Tip Hidrolik Somun Patlatma Ekipmanları

>Bolting Systems™ Hydraulic Nut Splitters

Standart	Su Altı Uyg.	Kesici Kafa	Somun Çapı Bolt Dia.		Anahtar Ağız Nut A/F		A	B	C	D	E	F	G	Ağırlık Weight
			Imperial	Metric	Inch	mm								
ENS1-C	ENS1-C-SS	ENS1-1H	3/4"	M20	1 1/4"	30	104	228	76	18	104	40.5	9	6.7
			7/8"	M22	1 7/16"	32								
			1"	M24	1 3/8"	36								
			-	M27	-	41								
		ENS1-2H	3/4"	M20	1 1/4"	30	104	239	90	21	110	40.5	10	6.9
			7/8"	M22	1 7/16"	32								
			1"	M24	1 3/8"	36								
			1 1/8"	M27	1 13/16"	41								
			1 1/4"	M30	2"	46								
			-	M33	-	50								
ENS2-C	ENS2-C-SS	ENS2-1H	1 1/8"	M30	1 13/16"	46	138	305	102	22	132	57.5	6	15.8
			1 1/4"	M33	2"	50								
			1 3/8"	M36	2 3/16"	55								
			1 1/2"	M39	2 3/8"	60								
		ENS2-2H	1 1/8"	M30	1 13/16"	46	138	314	114	23	141	57.5	6	16
			1 1/4"	M33	2"	50								
			1 3/8"	M36	2 3/16"	55								
			1 1/2"	M39	2 3/8"	60								
			1 5/8"	M42	2 9/16"	65								
			1 3/4"	M45	2 3/4"	70								
ENS3-C	ENS3-C-SS	ENS3-1H	1 3/4"	M45	2 3/4"	70	190	406	132	28	189	80.5	8	42
			1 7/8"	M48	2 15/16"	75								
			2"	M52	3 1/8"	80								
		ENS3-2H	1 3/4"	M45	2 3/4"	70	190	416	145	30	199	80.5	8	42.5
			1 7/8"	M48	2 15/16"	75								
			2"	M52	3 1/8"	80								
			2 1/4"	M56	3 1/2"	85								
		ENS3-3H	1 3/4"	M45	2 3/4"	70	190	426	160	31.5	200	80.5	7	43
			1 7/8"	M48	2 15/16"	75								
			2"	M52	3 1/8"	80								
			2 1/4"	M56	3 1/2"	85								
			2 1/2"	M60	3 7/8"	90								
		-	M64	-	95									
		ENS3-4H	1 3/4"	M45	2 3/4"	70	190	437	174	35	204	80.5	9	44
			1 7/8"	M48	2 15/16"	75								
			2"	M52	3 1/8"	80								
			2 1/4"	M56	3 1/2"	85								
			2 1/2"	M60	3 7/8"	90								
			2 3/4"	M64	4 1/4"	95								
			-	M68	-	100								
-	M72	-	105											
ENS4-C	ENS4-C-SS	ENS4-1H	2 3/4"	M76	4 1/4"	110	235	474	189	36.5	235	110.5	4	73
			3"	M80	4 5/8"	115								
		ENS4-2H	2 3/4"	M76	4 1/4"	110	235	495	219	41	240	110.5	3	75
			3"	M80	4 5/8"	115								
			3 1/4"	M85	5"	120								
			3 1/2"	M90	5 3/8"	130								