

NS12TE

NS15TE

NS20TE

NS36TE

EXTERNAL
HYDRAULIC
NUT SPLITTERS



CONTENTS

1. INTRODUCTION
2. TOOL SAFETY
 - 2.1 GENERAL SAFETY
 - 2.2 PERSONNEL COMPETENCY
 - 2.3 DISCLAIMER
 - 2.4 DEFINITION OF TERMS
 - 2.5 HAZARDS
3. TOOL OPERATION
 - 3.1 GENERAL GUIDANCE
 - 3.2 TOOL SELECTION
 - 3.3 HYDRAULIC TOOL OPERATION
 - 3.4 HANDLE
 - 3.5 SAFETY LANYARD
 - 3.6 POSITIONING THE TOOL
4. TOOL MAINTENANCE
 - 4.1 INSPECTION
 - 4.2 CLEANING
 - 4.3 CUTTING TIP REPLACEMENT
 - 4.4 MAINTENANCE
 - 4.5 STORAGE AND TRANSPORTATION
 - 4.6 OPERATING CONDITIONS
 - 4.7 SUB-SEA USAGE
5. TECHNICAL SPECIFICATIONS
 - 5.1 NS12TE KIT CONTENTS
 - 5.2 NS12TE TOOL DIMENSIONS
 - 5.3 NS15TE KIT CONTENTS
 - 5.4 NS15TE TOOL DIMENSIONS
 - 5.5 NS20TE KIT CONTENTS
 - 5.6 NS20TE TOOL DIMENSIONS
 - 5.7 NS36TE KIT CONTENTS
 - 5.8 NS36TE TOOL DIMENSIONS
6. TROUBLESHOOTING
 - 6.1 NS12TE/NS15TE/NS20TE/NS36TE TROUBLESHOOTING
7. REGULATORY INFORMATION
 - 7.1 REGISTERED HEAD OFFICE
8. PARTS LISTS & SERVICE KITS

06/10/2016

1.

INTRODUCTION

The Equalizer™ NS Range of tools has been developed to assist in the removal of corroded, seized or damaged nuts.

The NS tools have a shrouded cutting head to contain the split nut and have been developed to increase the access to tight flange joints. The tools have no exposed finger pinch points and are supplied with a swivel handle and a safety lanyard as standard.



It is essential that the users familiarise themselves with the contents of this manual prior to using the tool.

This manual contains information for the following tools:

- NS12TE External Hydraulic Nut Splitter
- NS15TE External Hydraulic Nut Splitter
- NS20TE External Hydraulic Nut Splitter
- NS36TE External Hydraulic Nut Splitter

2.

TOOL SAFETY

2.1

GENERAL SAFETY

These instructions cover the safe operation and maintenance of THE EQUALIZER **NS12TE, NS15TE, NS20TE** and **NS36TE** NUT SPLITTER tools. The use of these tools should be as part of a broader task-based risk assessment, which should be carried out by the operation supervisor or other competent person.

Failure to comply with the safety information contained within this manual could result in personal injury or equipment damage. Read all instructions, warnings and cautions carefully, and follow all safety precautions.

The safety of the operator, any assisting personnel and the general public is of paramount importance. Always work in accordance with applicable national, local, site & company-wide safety procedures.

2.2

PERSONNEL COMPETENCY

Only personnel deemed competent in the use of mechanical and hydraulic equipment should use these tools.

2.3

DISCLAIMER

Equalizer cannot be held responsible for injury or damage resulting from unsafe product use, lack of maintenance or incorrect product and/or system operation. If in doubt as to the safety precautions and applications, contact Equalizer using the contact details at the back of this manual.

2.4

DEFINITION OF TERMS

A **CAUTION** is used to indicate correct operating or maintenance procedures and practices to prevent damage to, or destruction of equipment or other property.

A **WARNING** indicates a potential danger that requires correct procedures or practices to avoid personal injury.

A **DANGER** is only used when your action or lack of action may cause serious injury or even death.



DO: an illustration showing how the tool should be used.



DON'T: an illustration showing an incorrect way to use a tool.

2.5

HAZARDS



WARNING: ensure all hydraulic components are rated to a safe working pressure of 700 bar (10 000 psi).



WARNING: Do not overload equipment. The risk of hydraulic overloading can be minimised by using the Equalizer Hand Pump, which has a factory-set safety valve preventing the safe working pressure being exceeded.

If alternative hydraulic pumps are used, ensure that there are adequate systems to limit the the working pressure to 700 bar (10 000 psi).



CAUTION: ensure components are protected from external sources of damage, such as excessive heat, flame, moving machine parts, sharp edges and corrosive chemicals.



CAUTION: Take care to avoid sharp bends and kinks in hydraulic hoses. Bends and kinks can cause severe back-up pressure and cause hose failure. Protect hoses from dropped objects; a sharp impact may cause internal damage to hose wire strands. Protect hoses from crush risks, such as heavy objects or vehicles; crush damage can cause hose failure.



WARNING: Applying pressure to a damaged hose may cause it to rupture.



WARNING: Immediately replace worn or damaged parts. Use only genuine Equalizer parts from approved distributors or service centres. Equalizer parts have been engineered and manufactured to be fit-for-purpose.



DANGER: To minimise risk of personal injury keep hands and feet away from the tool and workpiece during operation.



WARNING: Always wear suitable clothing and Personal Protective Equipment (PPE). Do not handle pressurised hoses; escaping oil under pressure can penetrate the skin, causing serious injury. Seek medical attention immediately if oil penetration is suspected.



WARNING: Only pressurize complete and fully connected hydraulic systems. Do not pressurize systems that contain unconnected couplers.



CAUTION: Do not lift hydraulic equipment by the hoses or couplers. Use only the designated carrying handles.



CAUTION: Lubricate tools as directed in this manual prior to operation. Use only approved lubricants of high quality, following the lubricant manufacturers instructions.



CAUTION: Only use the designated anchor point for fixing the safety lanyard. Do not attach the safety lanyard to the plastic handle.



DANGER: Care should be taken when using the safety lanyard to avoid entanglement with body parts.

3.

TOOL OPERATION

If the specification of the nut is unknown then a vernier calliper or measure tape should be used to determine the Across-Flats (A/F) size of the nut to be split and the correct tool.

3.1

GENERAL GUIDANCE

The Equalizer™ Nut Splitter Tools are suited to fit a range of nut sizes and grades and the right tool should be selected prior to commencing work by following the instructions in this section.

3.2

TOOL SELECTION



CAUTION: It is important that the correct tool is selected for each nut and the correct Cutting Tip is used for each tool. Each tool in the Nut Splitter range comes with the appropriate Cutting Tips for that tool. Please refer to the table below to choose the correct tool for your application.

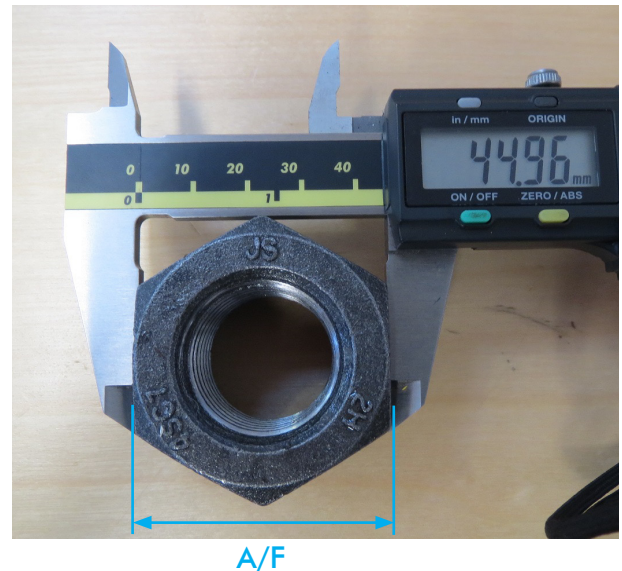

NUT SPLITTER	HEX NUT A/F	METRIC (COARSE)	UNC (STANDARD)	UNC (HEAVY)
NS12	17.5 mm - 30.0 mm (0.69" - 1.18")	M12 - M20	9/16" - 5/8"	1/2" - 5/8"
NS15	23.0 mm - 36.5 mm (0.91" - 1.44")	M16 - M22	5/8" - 7/8"	9/16" - 7/8"
NS20	32.0 mm - 51.0 mm (1.26" - 2.01")	M24 - M30	1" - 1 1/4"	7/8" - 1 1/8"
NS36	50.8 mm - 65.0 mm (2.00" - 2.56")	M33 - M42	1 3/8" - 1 5/8"	1 1/4" - 1 5/8"
NS50	65.0 mm - 80.0 mm (2.56" - 3.15")	M45 - M52	1 3/4" - 2"	1 5/8" - 2"
NS75	79.4 mm - 100.0 mm (3.13" - 3.94")	M56 - M68	2 1/4" - 2 1/2"	2" - 2 1/2"
NS100	98.4 mm - 115.0 mm (3.87" - 4.53")	M72 - M80	2 3/4" - 3"	2 1/2" - 3"

3.3 HYDRAULIC TOOL OPERATION

The NS12TE/NS15TE/NS20TE/NS36TE Nut Splitters require an external hydraulic pump to drive the cylinder and advance the Cutting Tip to split the nut.

Consult the manufacturer’s Instruction Manual for the hydraulic pump operation.

USING THE NS12TE/NS15TE/NS20TE/NS36TE

Position the tool as per Section 3.6.

When the pump is operated the piston and the Cutting Tip will advance. Ensure the tool is flat against the flange and the Cutting Tip perpendicular to the nut throughout the operation. Slowly actuate the Nut Splitter to advance the Cutting Tip against a flat of the nut and increase the pressure until the nut splits.

Releasing the pump will depressurise the cylinder and cause it to retract under the force of its internal spring.

It is likely that the nut will require a second split to fully remove the nut from the stud. Ideally a second split should be carried out at 180° to the first cut, splitting the nut in half to enable removal.

After the nut has been split, always check the Cutting Tip for damage and replace if required before positioning the tool on another nut.

 **CAUTION:** Split nuts often have sharp edges and should be handled with great care.

3.4 HANDLE

The handle can be swivelled around the central axis of the tool, to improve access to the nut and allow the tool to be easily held in the vertical or horizontal orientation.

3.5 SAFETY LANYARD

The NS tools are supplied with a secure anchor point and a safety lanyard. The safety lanyard should be used to minimise the risks associated with the tool dropping.

Attach one end of the safety lanyard to the tool using the supplied shackle. The other end of the safety lanyard should be fixed to a secure point close to the work-site using an appropriate shackle.

Avoid using the safety lanyard as a means for picking up or carrying the tool. Do not fix the safety lanyard to the handle.

The anchor point and safety lanyard have been engineered to safely sustain a drop over the full safety lanyard length. It is recommended that all parts are inspected following a drop incident, as damage may compromise the safety of the tool.



CAUTION: Only use the designated anchor point for fixing the safety lanyard. Do not attach the safety lanyard to the plastic handle.



DANGER: Care should be taken when using the safety lanyard to avoid entanglement with body parts.

3.6 POSITIONING THE TOOL

Prior to splitting the nut, an assesment should be carried out to determine the most appropriate positioning of the tool around the nut.

Please see next page for more information.

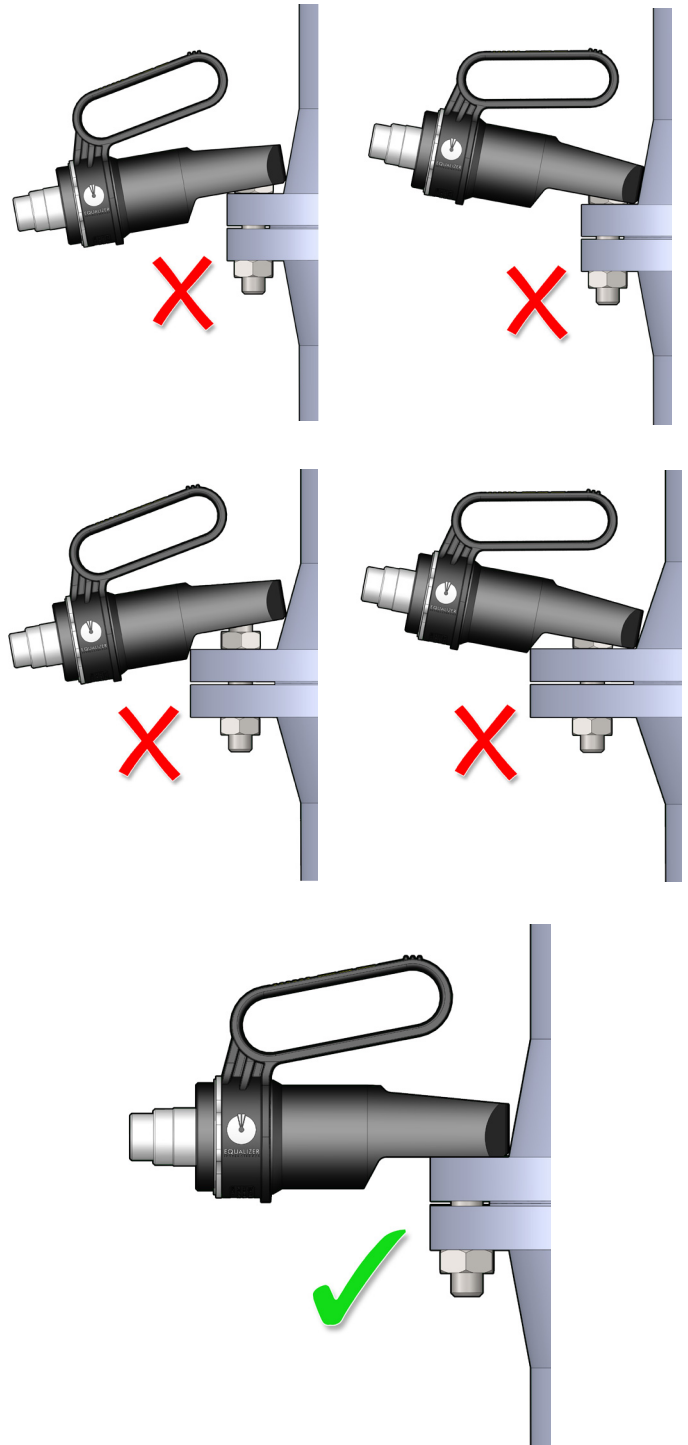
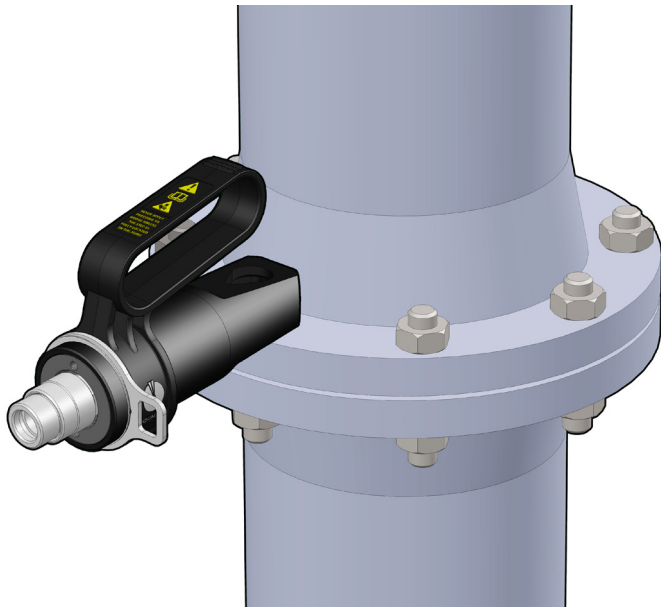

Place the tool on the nut with the flat surface of the cutting head flat against one of the nut flats and the Cutting Tip centered. Ensure the bottom face of the cutting head sits flat on the same surface that the nut is seated.

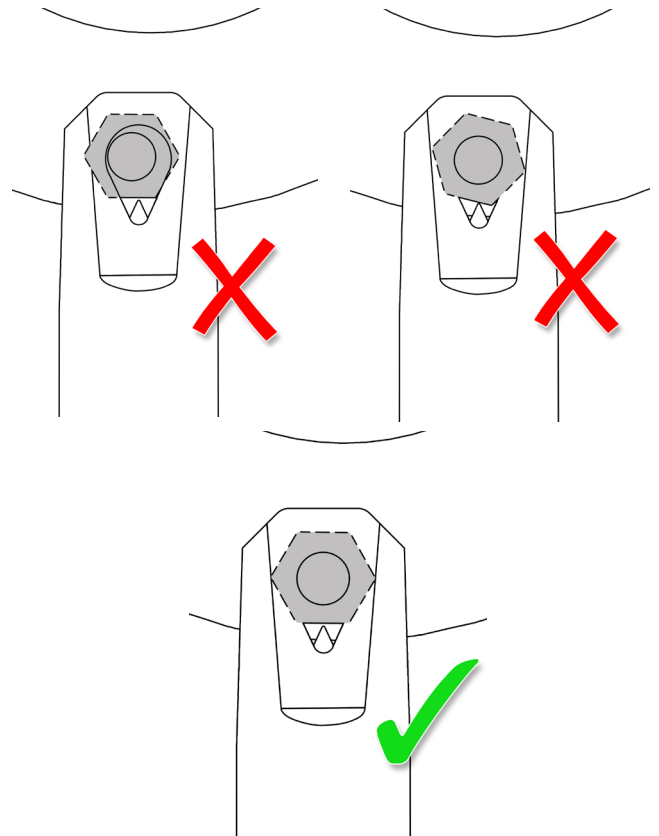
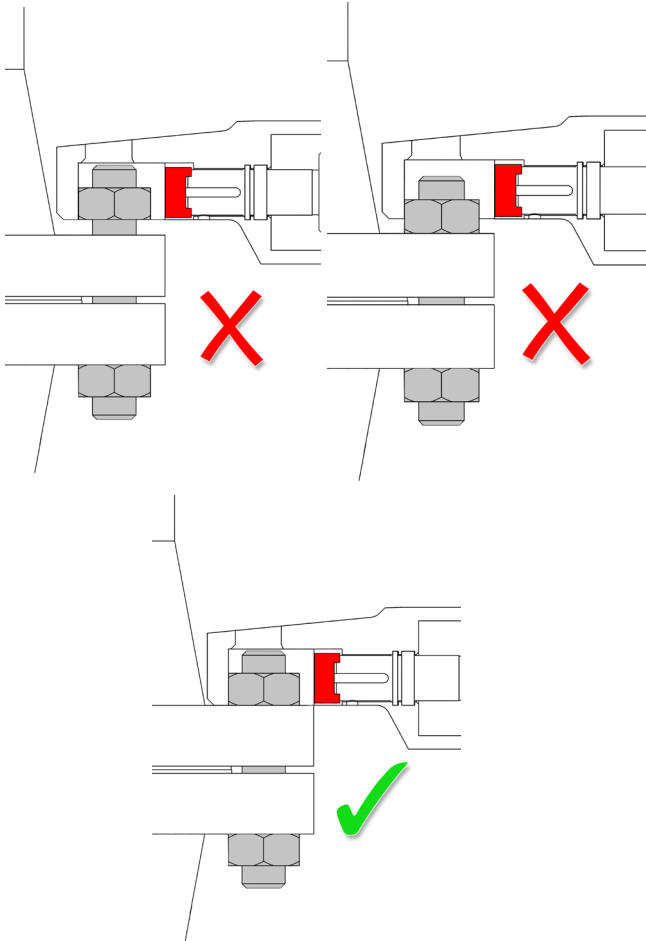

CAUTION: It is recommended that suitable hearing protection, i.e. ear defenders or ear plugs are worn.



CAUTION: It is recommended that a face shield or suitable eye protection, i.e. safety glasses or goggles are worn.

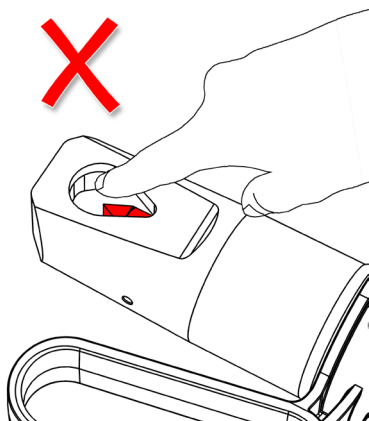

4.

TOOL MAINTENANCE

4.1 INSPECTION

A thorough inspection should be carried out prior to usage, storage or transportation to ensure the completeness and condition of the tool.

Inspection should include:

- visual inspection of the outer parts of the tool, checking for obvious damage, degradation or missing parts
- visual inspection of the Cutting-Tip (this may require tool actuation)

Cleaning and servicing should be undertaken as required prior to the tool being used, stored or transported.

4.2 CLEANING

To lightly clean the tool, wipe gently with a damp cloth.

If more thorough cleaning is required (for example following immersion in water) carry out the following cleaning procedure:

- strip the tool down, observing the schematics in section 8
- clean the components using detergent, following the manufacturer’s guidelines
- rinse the components to remove traces of detergent
- dry the components thoroughly

Inspect, service and lubricate the tool immediately after the cleaning process.

4.3 CUTTING TIP REPLACEMENT

Ensure the correct Cutting Tip is fitted to the tool and has been checked for damage. Some minor blunting is acceptable, but cracked or chipped Cutting Tips should be replaced.

The Cutting Tip is retained in the piston by the tip retention screw. Unscrew the tip retention screw with a hex-key and pull the Cutting Tip out to replace. Do not apply excessive force when inserting the Cutting Tip into the tool. If the Cutting Tip does not come out easily, slightly extend the piston to gain better access. When replacing the Cutting Tip, the tip retention screw and alignment screw should also be replaced every time.

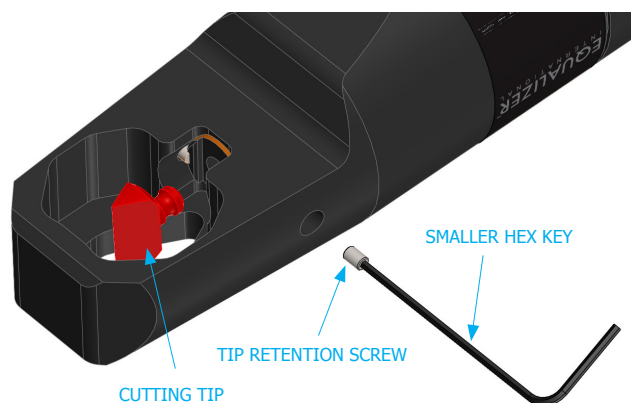

CAUTION: Ensure the tip retention screw is screwed tightly into in the piston and the hex key removed before actuating the tool.

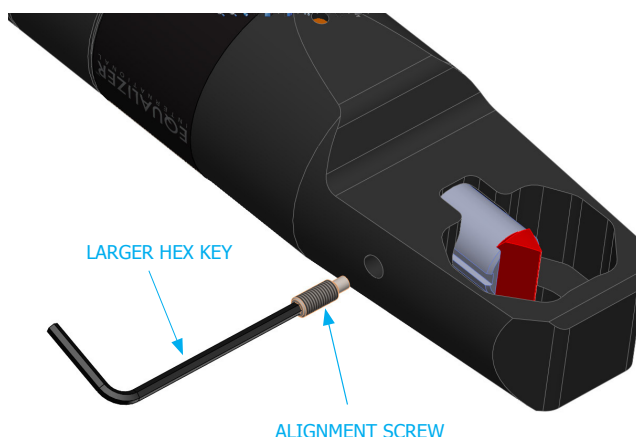

A thick grease should be applied to the Cutting Tip before every cut. This will ease the splitting operation, prolong the life of the Cutting Tip and limit the risk of sparking and debris projectiles.

4.4 MAINTENANCE

Replace missing, worn or damaged parts. Use only genuine Equalizer parts from approved distributors or service centres. Equalizer parts have been engineered and manufactured to be fit-for-purpose.

Do not apply excessive force when inserting the Cutting Tips into the tool. Always replace the tip retention screw and alignment screw when replacing the Cutting Tip.

The alignment screw in the side of the cutting head sits in the slot of the piston and keeps the Cutting Tip aligned. This screw should not be fully tightened; back off the alignment screw by 1/4 turn after insertion.



If topping up or replacing hydraulic oil as part of a service, use only premium quality hydraulic oil of the grade 15 cSt.

A thick grease should be applied to the Cutting Tip **before every cut**. This will ease the splitting operation, prolong the life of the Cutting Tip and limit the risk of sparking and debris projectiles.

4.5 STORAGE & TRANSPORTATION

Equalizer tools should be stored in a cool dry place. Tools should always be cleaned, serviced and lubricated prior to storage. Ensure that tools are stored in their designated packing cases.

4.6 OPERATING CONDITIONS

Minimum Cutting Tip Contact Temperature: -20 °C
 Maximum Cutting Tip Contact Temperature: 70 °C

4.7 SUB-SEA USAGE

The Equalizer range of HP hydraulic hand pumps are fitted with a sealed-bladder type reservoir system that allows for sub-sea operation.

Using Equalizer External Hydraulic Nut-Splitters

The NS12TE/NS15TE/NS20TE/NS36TE are actuated by means of single-acting spring-return hydraulic cylinder and can be used sub-sea providing the following actions are taken:

- The gauges and manifolds are removed from the hand-pump and the coupler is fitted directly to the pump outlet.
- The tool is connected to the pump whilst still top-side.
- The pump release valve is fully opened and remains open until the tool has descended to the working depth. This will allow the pressure to equalise.
- The tool is actuated via the hand pump by a diver.
- Upon completion of works the release valve is left in the fully-open position until the tool has ascended to the surface.
- The tool and pump are stripped-down, cleaned and lubricated immediately to minimise corrosion.



CAUTION: Please note that the NS12TE/NS15TE/NS20TE/NS36TE tools cannot be operated from top-side by use of a down-line. The return springs in the hydraulic cylinders do not have sufficient force to retract the piston if used with a down-line from a top-side pump, therefore the standard hydraulic tools will not function correctly and may jam in place if used in this configuration.

5.

TECHNICAL SPECIFICATIONS

5.1

NS12TE KIT CONTENTS

Product Code: NS12TEMIN

- 1 x NS12TE Nut Splitter
- 1 x Spare Cutting Tip
- 1 x Spare Tip Retention Screw
- 1 x Spare Alignment Screw
- 1 x Set of Hex Keys
- 1 x Safety Lanyard
- 1 x Instruction Manual
- 1 x Carry Case



580 mm x 350 mm x 180 mm (22.8" x 13.8" x 7.1")

Tool only Weight: 3.5 kg (7.7 lb)
Gross Kit Weight: 6.8 kg (15.0 lb)

5.2

NS12TE TOOL DIMENSIONS



5.3

NS15TE KIT CONTENTS

Product Code: NS15TEMIN

- 1 x NS15TE Nut Splitter
- 1 x Spare Cutting Tip
- 1 x Spare Tip Retention Screw
- 1 x Spare Alignment Screw
- 1 x Set of Hex Keys
- 1 x Safety Lanyard
- 1 x Instruction Manual
- 1 x Carry Case



580 mm x 350 mm x 180 mm (22.8" x 13.8" x 7.1")

Tool only Weight: 4.0 kg (8.8 lb)
Gross Kit Weight: 7.1 kg (16.7 lb)

5.4

NS15TE TOOL DIMENSIONS



5.5 NS20TE KIT CONTENTS

Product Code: NS20TEMIN

- 1 x NS20TE Nut Splitter
- 1 x Spare Cutting Tip
- 1 x Spare Tip Retention Screw
- 1 x Spare Alignment Screw
- 1 x Set of Hex Keys
- 1 x Safety Lanyard
- 1 x Instruction Manual
- 1 x Carry Case



580 mm x 350 mm x 180 mm (22.8" x 13.8" x 7.1")

Tool only Weight: 6.9 kg (15.2 lb)
Gross Kit Weight: 10.2 kg (22.5 lb)

5.7 NS36TE KIT CONTENTS

Product Code: NS36TEMIN

- 1 x NS36TE Nut Splitter
- 1 x Spare Cutting Tip
- 1 x Spare Tip Retention Screw
- 1 x Spare Alignment Screw
- 1 x Set of Hex Keys
- 1 x Safety Lanyard
- 1 x Instruction Manual
- 1 x Carry Case



580 mm x 350 mm x 180 mm (22.8" x 13.8" x 7.1")

Tool only Weight: 10.6 kg (23.4 lb)
Gross Kit Weight: 13.6 kg (30.0 lb)

5.6 NS20TE TOOL DIMENSIONS



5.8 NS36TE TOOL DIMENSIONS

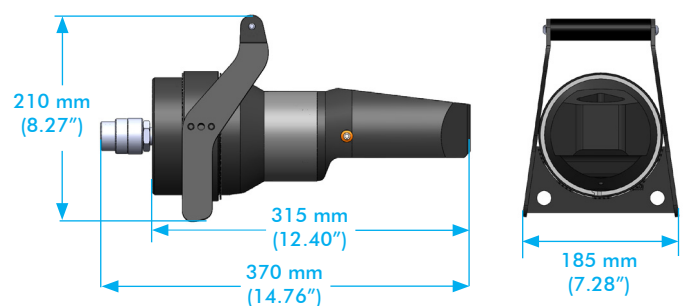

6.

TROUBLESHOOTING

6.1

NS12TE/NS15TE/NS20TE/NS36TE TROUBLESHOOTING

THE PISTON ADVANCES BUT THE TOOL DOES NOT SPLIT THE NUT

POSSIBLE CAUSE:

The Cutting Tip is damaged.

RECOMMENDED ACTION:

Remove pressure from the system then check for any damage to the Cutting Tip. If signs of damage are present replace the Cutting Tip. (See Section 4.3).

POSSIBLE CAUSE:

The Cutting Tip is not aligned.

RECOMMENDED ACTION:

Remove pressure from the system then check that the alignment screw is located in the alignment slot on the piston. If necessary, replace the alignment screw. (See Section 4.3).

THE PISTON IS ADVANCING BUT DOES NOT REACH FULL PRESSURE

POSSIBLE CAUSE:

There is air in the hydraulic system.

RECOMMENDED ACTION:

Follow the Airlock Relief instructions below.

THE CUTTING TIP DOES NOT LAST AS WELL AS EXPECTED

POSSIBLE CAUSE:

Using very hard nuts (such as 2H grade) will significantly shorten the life of a Cutting Tip.

RECOMMENDED ACTION:

Ensure grease is applied generously to the Cutting Tip before each cut. When cutting very hard nuts ensure an adequate stock of spare Cutting Tips are available.

THE TOOL IS NOT SPLITTING THE NUT, EVEN AT FULL PRESSURE

POSSIBLE CAUSE:

Sometimes multiple attempts are required to split larger or particularly high-grade (e.g. 2H) nuts.

RECOMMENDED ACTION:

Release the pressure and actuate the tool repeatedly until the nut is split.

RECOMMENDED ACTION:

Check the Cutting Tip is sharp and that grease has been applied generously.

AIR-LOCK RELIEF

If full pressure is not achieved an air-lock may be present in the hydraulic system. Please refer to the pump instruction manual to relieve any air locks.

7.

REGULATORY INFORMATION

7.1

REGISTERED HEAD OFFICE

EQUALIZER INTERNATIONAL LTD.
Equalizer House
Claymore Drive
Aberdeen
Scotland
AB23 8GD

8.

PARTS LISTS & SERVICE KITS

NS12TE PARTS LIST

1070000-01 REV.02

ITEM NO.	PART NO	DESCRIPTION	QTY
1	NOT AVAILABLE	CUTTING HEAD	1
2	1000300-01	PISTON	1
3	NOT AVAILABLE	NS12TE Body Sticker Wrap	1
4	300901-01	3/8" NPT COUPLER 10kPSI	1
5	1002600-01	Cylinder End Cap	1
6	KIT 1075100-01	NS12 CUTTING TIP	1
7		ALIGNMENT SCREW	1
8		M4 x 6mm Grub Screw	1
9	KIT 1001700-01	WIPER SEAL	1
10		O-RING	1
11		BACK-UP RING	1
12		WMU Plain Bushing	1
13		BEARING STRIP	1
14		COMPRESSION COIL SPRING	1
15		CYL VENT PLUG	1
16		PISTON LIP SEAL	1
17		SPRING SHIM	1
18	KIT 1001800-01	SPIRAL RETAINING RING	2
19		ANCHOR POINT	1
20		HANDLE	1
21		HANDLE STICKER	1

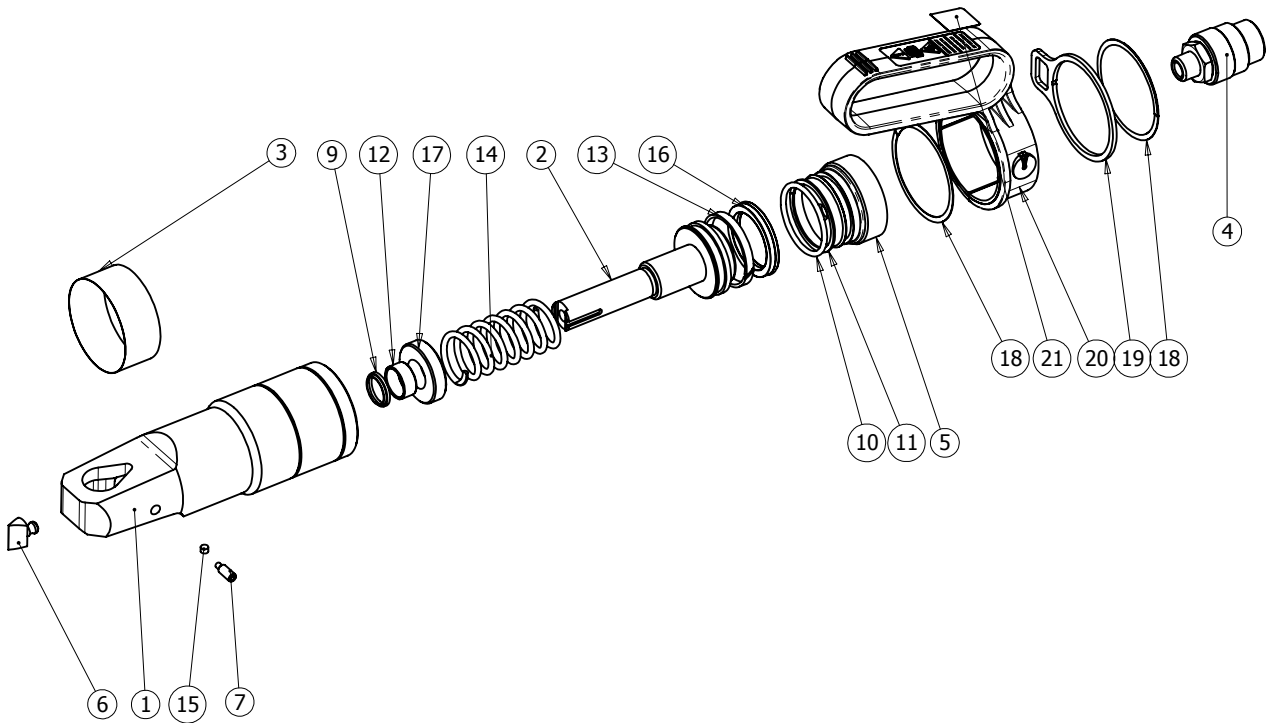

NS15TE PARTS LIST

1000000-01 REV.02

ITEM NO.	PART NO	DESCRIPTION	QTY
1	NOT AVAILABLE	CUTTING HEAD	1
2	1000300-01	PISTON	1
3	NOT AVAILABLE	NS15TE Body Sticker Wrap	1
4	771110-01	3/8" NPT COUPLER 10kPSI	1
5	1002600-01	Cylinder End Cap	1
6	KIT 1005100-01	CUTTING TIP	1
7		ALIGNMENT SCREW	1
8		M4 x 6mm Grub Screw	1
9	KIT 1001700-01	WIPER SEAL	1
10		O-RING	1
11		BACK-UP RING	1
12		WMU Plain Bushing	1
13		BEARING STRIP	1
14		COMPRESSION COIL SPRING	1
15		CYL VENT PLUG	1
16		PISTON LIP SEAL	1
17		SPRING SHIM	1
18	KIT 1001800-01	SPIRAL RETAINING RING	2
19		ANCHOR POINT	1
20		HANDLE	1
21		HANDLE STICKER	1

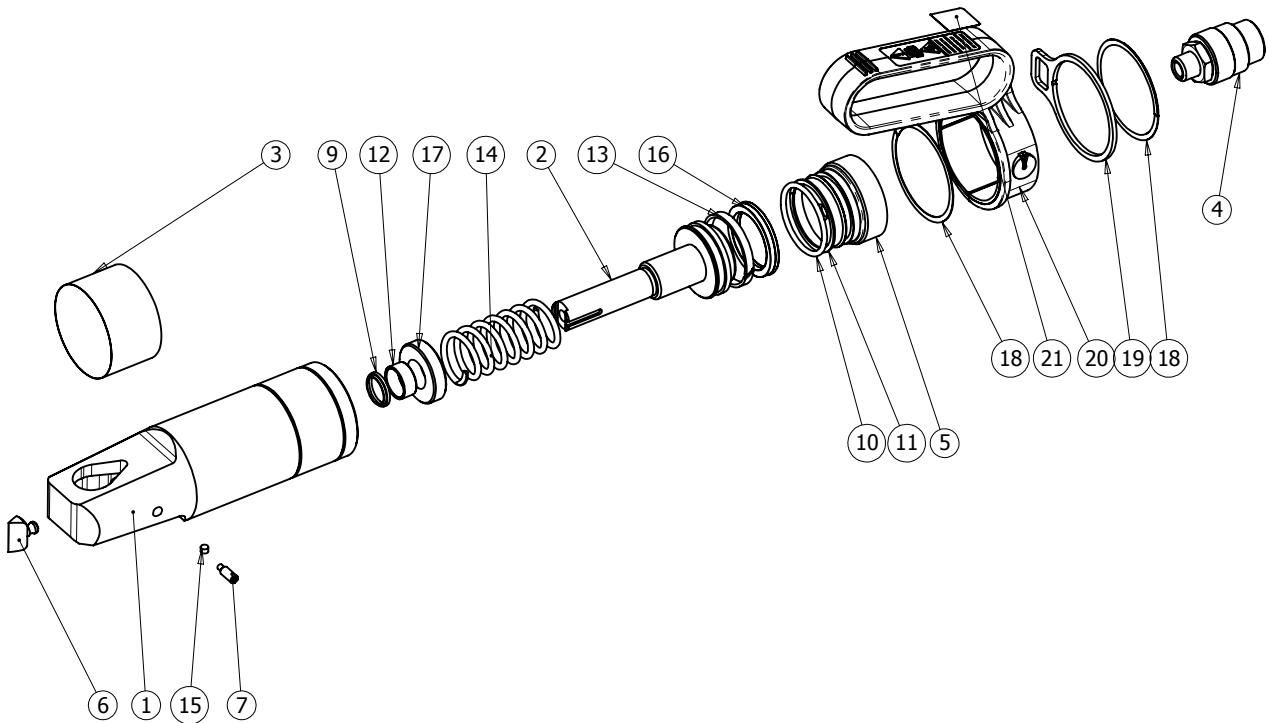

NS20TE PARTS LIST

1020000-01 REV.03

ITEM NO.	PART NO	DESCRIPTION	QTY
1	NOT AVAILABLE	CUTTING HEAD	1
2	1020300-01	PISTON	1
3	NOT AVAILABLE	NS20TE Body Sticker Wrap	1
4	1020900-01	CYLINDER END CAP	1
5	300901-01	3/8" NPT COUPLER 10kPSI	1
6	KIT 1025100-01	CUTTING TIP	1
7		ALIGNMENT SCREW	1
8		M5 SCKT SET SCREW	1
9	KIT 1021900-01	WIPER SEAL	1
10		O-RING BS-4518-0545-30	1
11		BACK-UP RING BS-4518-0545-30	1
12		WMU PLAIN BUSHING	1
13		PISTON BEARING STRIP	1
14		CYL VENT PLUG	1
15		COMPRESSION COIL SPRING	1
16		PISTON LIP SEAL	1
17		SPRING SHIM	1
18	KIT 1023000-01	ANCHOR POINT (PLATING)	1
19		Modular Handle Assembly	1
20		Spiral Ring	2

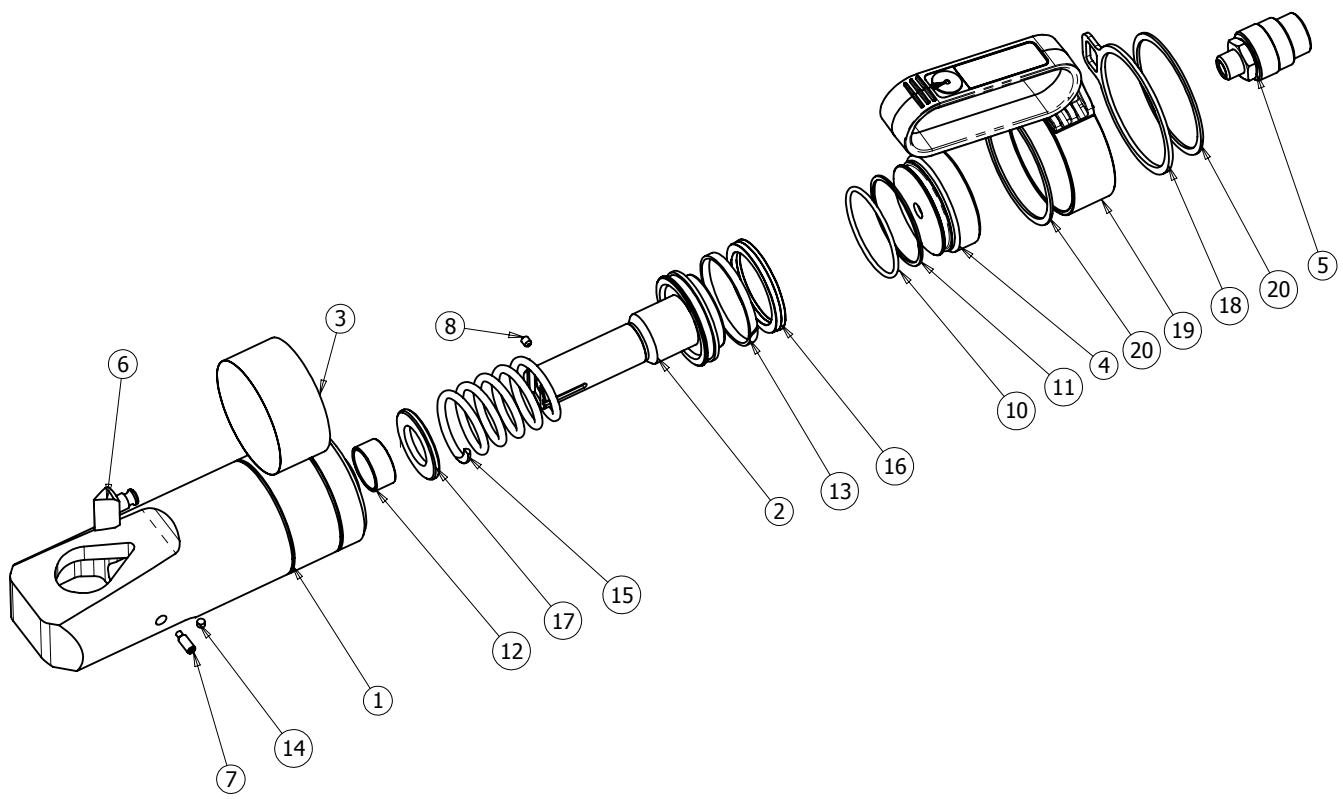

NS36TE PARTS LIST

1030000-01 DEV.01

ITEM NO.	PART NO	DESCRIPTION	QTY
1	NOT AVAILABLE	CUTTING HEAD - INSPECTION	1
2	1030300-01	PISTON	1
3	NOT AVAILABLE	NS36TE BODY STICKER WRAP	1
4	1030900-01	CYLINDER END CAP	1
5	KIT 1035100-01	CUTTING TIP - INSPECTION	1
6		ALIGNMENT SCREW	1
7		M8 x 10mm GRUB SCREW	1
8	KIT 1035500-01	CYL VENT PLUG	1
9		WIPER SEAL	1
10		WMU PLAIN BUSHING	1
11		BEARING & WIPER CARTRIDGE	1
12		COMPRESSION SPRING	1
13		PISTON BEARING RING	1
14		PISTON LIP SEAL	1
15		END CAP O-RING	1
16		BACK-UP RING	1
17	KIT 1035700-01	HANDLE ASSEMBLY	1
18		SPIRAL RETAINING RING	2
19	300901-01	3/8" NPT COUPLER 10ksi	1

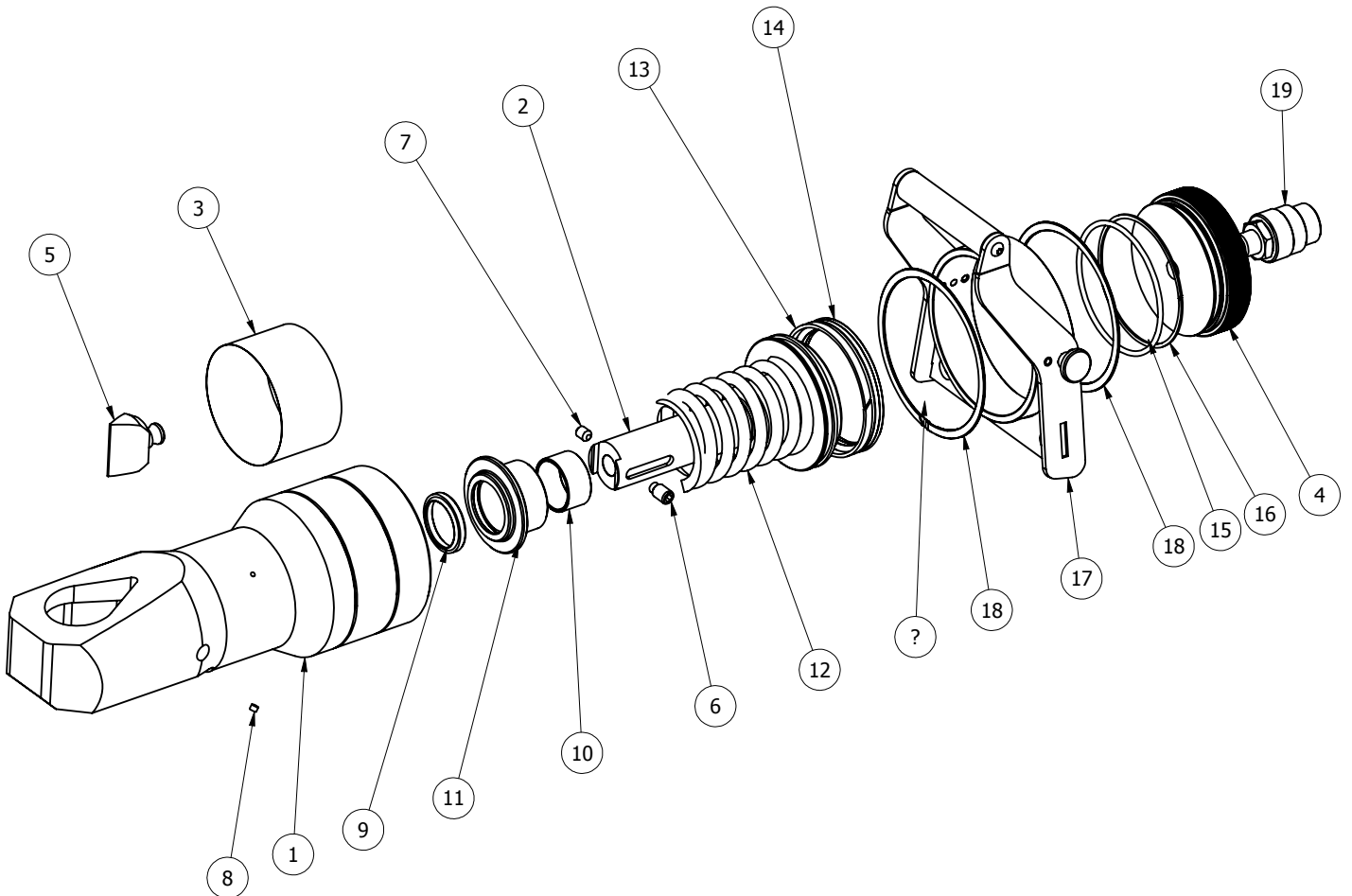

NS12 & NS15 CYLINDER REPAIR KIT

1001700-01 REV.02

ITEM NO.	DESCRIPTION	QTY
1	CYL VENT PLUG	1
2	WIPER SEAL	1
3	WMU Plain Bushing	1
4	COMPRESSION COIL SPRING	1
5	SPRING SHIM	1
6	BEARING STRIP	1
7	PISTON LIP SEAL	1
8	O-RING	1
9	BACK-UP RING	1

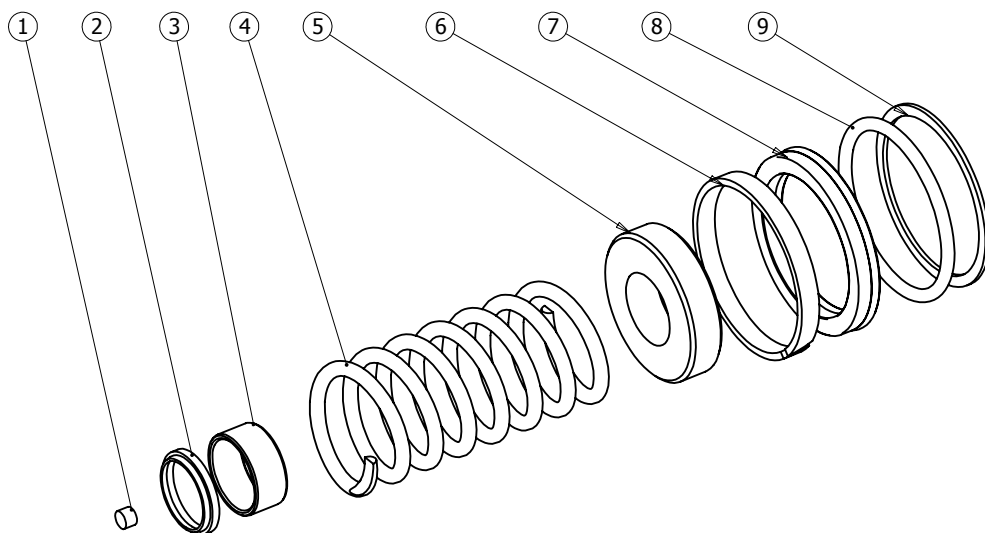

NS20TE CYLINDER SERVICE KIT

1021900-01 REV.03

ITEM NO.	DESCRIPTION	QTY
1	CYL VENT PLUG	1
2	WIPER SEAL	1
3	WMU PLAIN BUSHING	1
4	SPRING SHIM	1
5	COMPRESSION COIL SPRING	1
6	PISTON BEARING STRIP	1
7	PISTON LIP SEAL	1
8	O-RING	1
9	BACK-UP RING	1

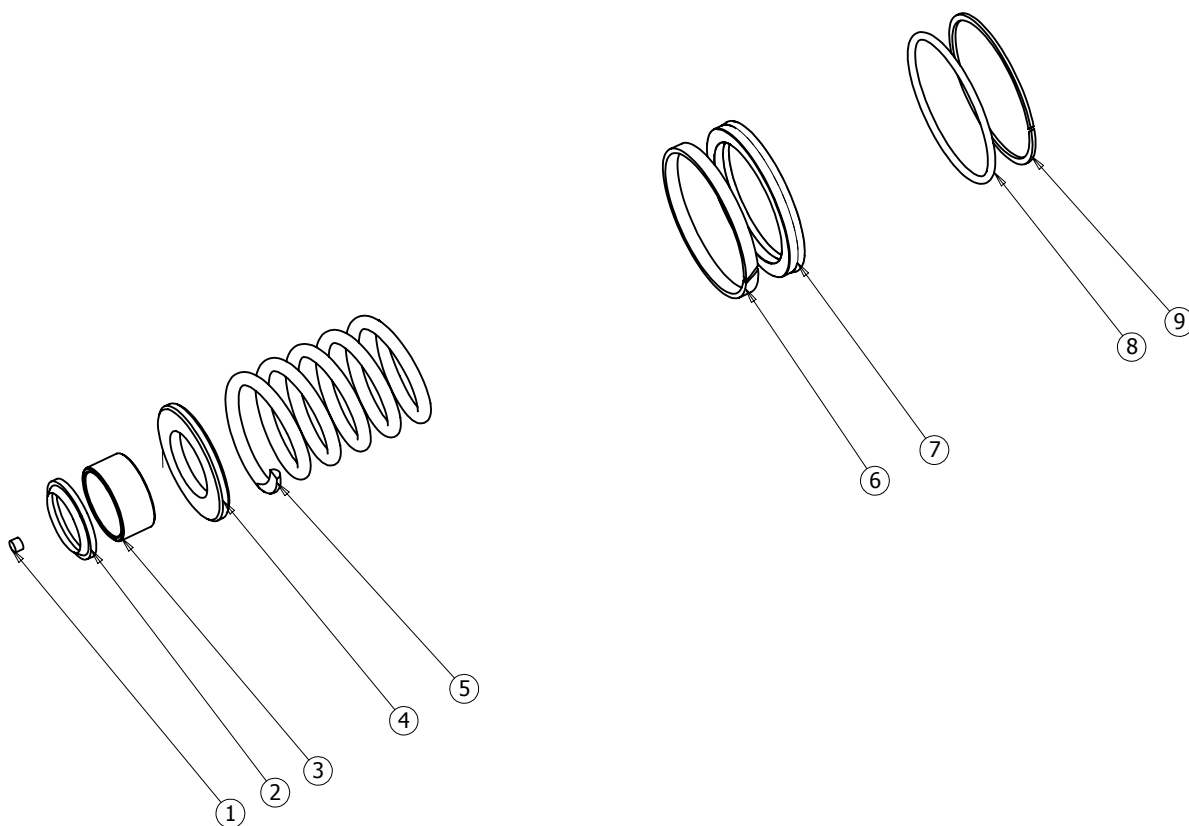

NS36TE CYLINDER SERVICE KIT

1035500-01 FIRST ISSUE

ITEM NO.	PART NO.	DESCRIPTION	QTY.
1	830310-01	CYL VENT PLUG	1
2	1030400-01	WIPER SEAL	1
3	1032500-01	WMU PLAIN BUSHING	1
4	1032900-01	BEARING & WIPER CARTRIDGE	1
5	1033600-01	COMPRESSION SPRING	1
6	1031700-01	PISTON BEARING RING	1
7	1030600-01	PISTON LIP SEAL	1
8	1031000-01	END CAP O-RING	1
9	1031100-01	BACK-UP RING	1

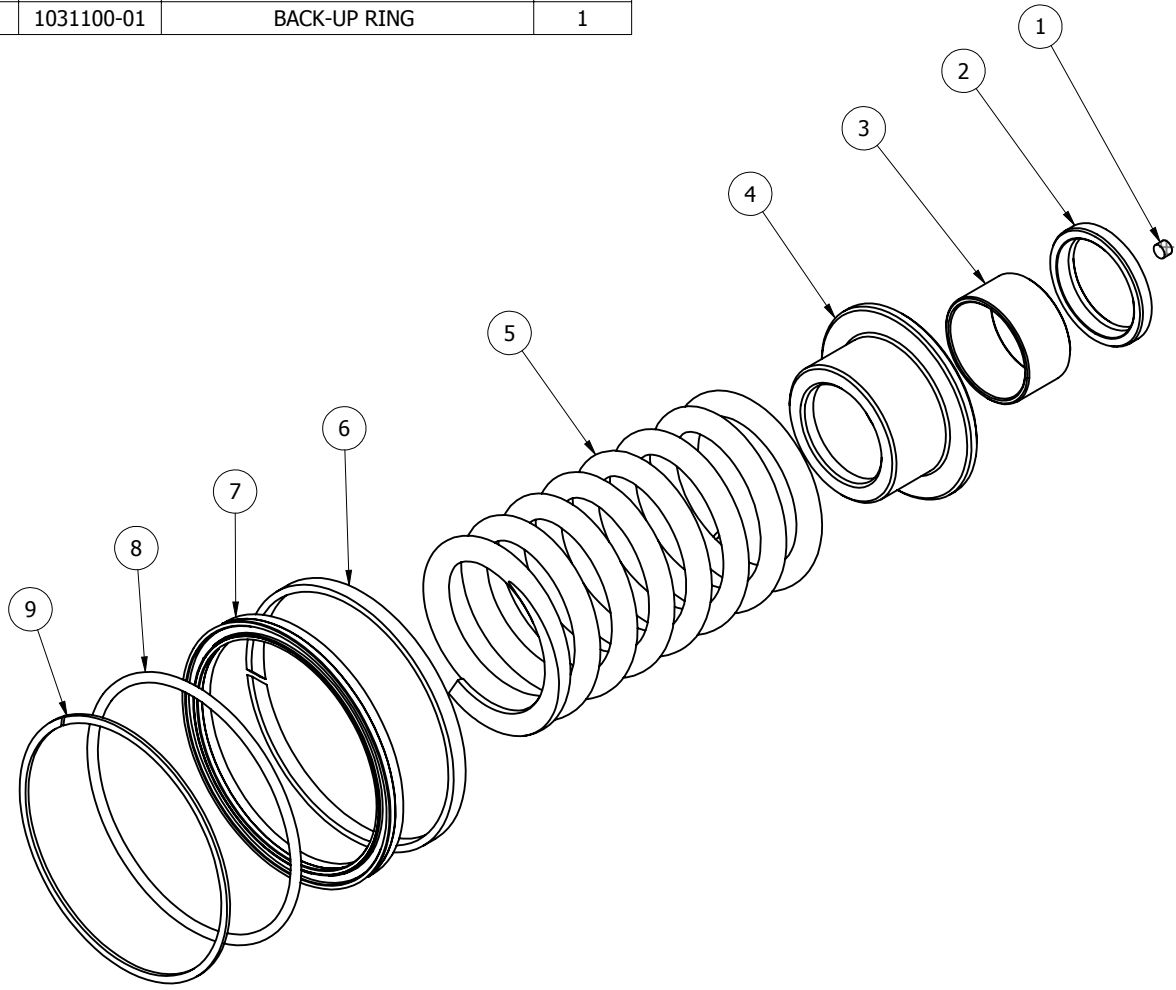

NS12 / NS15 HANDLE SERVICE KIT

1001800-01 REV.02

ITEM NO.	DESCRIPTION	QTY
1	SPIRAL RETAINING RING	2
2	ANCHOR POINT	1
3	HANDLE	1
4	HANDLE STICKER	1

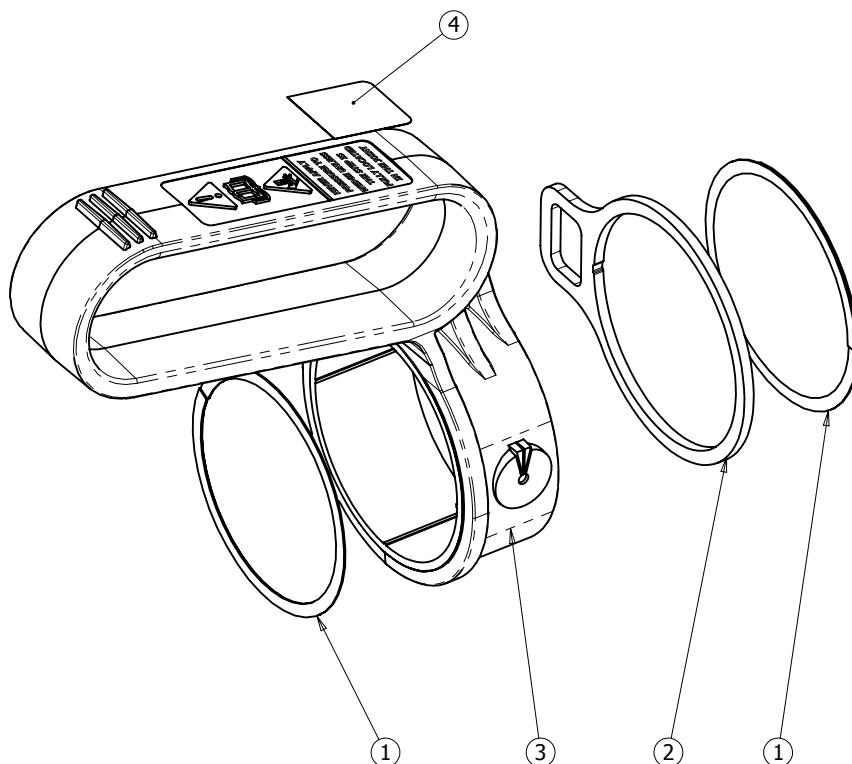

NS20 HANDLE SERVICE KIT

1023000-01 REV.03

ITEM NO.	DESCRIPTION	QTY
1	ANCHOR POINT	1
2	Modular Handle Assembly	1
3	Spiral Ring	2

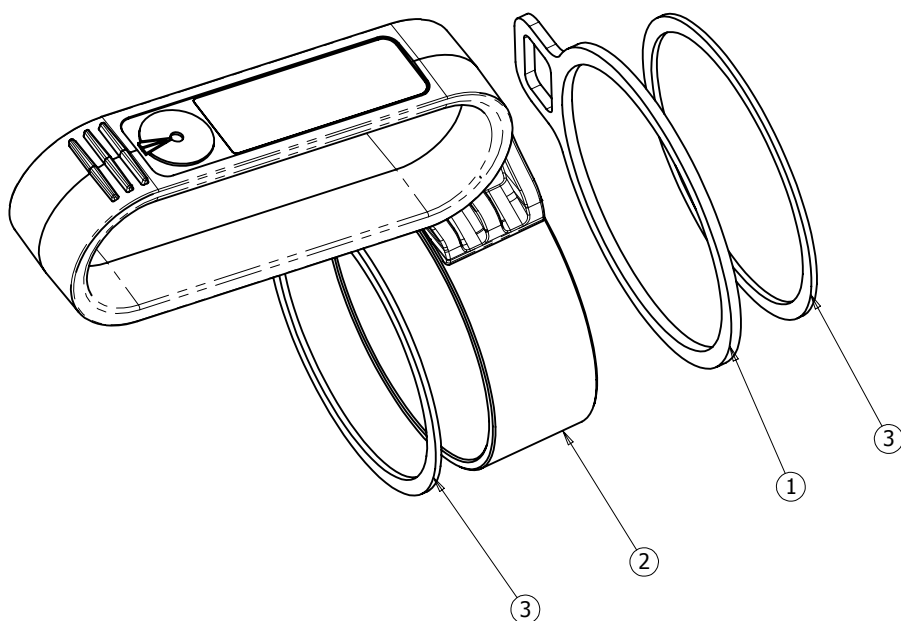

NS36TE HANDLE SERVICE KIT

1035700-01 FIRST ISSUE

ITEM NO.	PART NO.	DESCRIPTION	QTY.
1	1032100-01	HANDLE ASSEMBLY	1
2	1030200-01	SPIRAL RETAINING RING	2

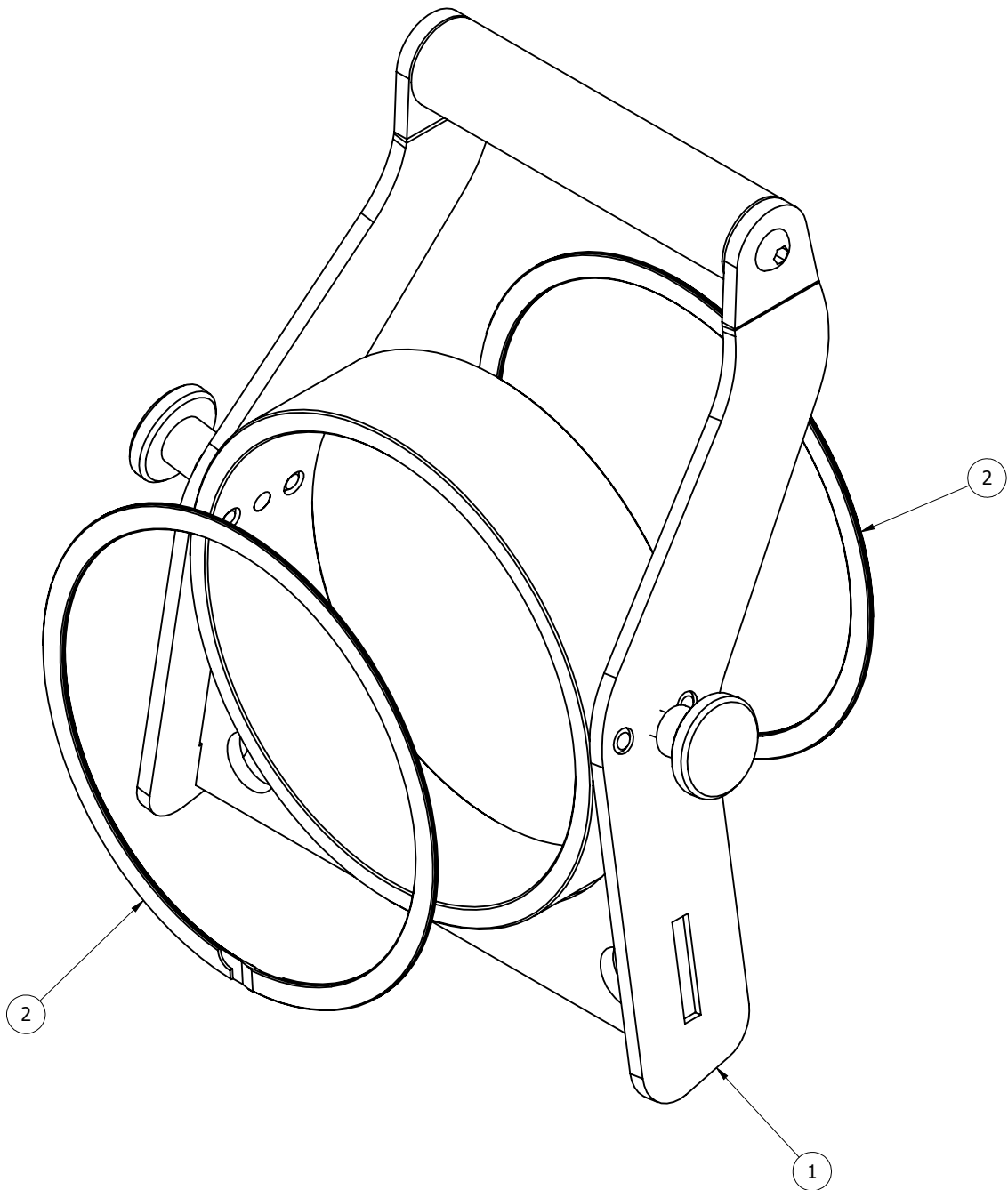

NS12 CUTTING TIP SERVICE KIT (1x)

1075100-01-01 REV.02

ITEM NO.	DESCRIPTION	QTY
1	NS12 CUTTING TIP	1
2	M4 x 6mm Grub Screw	1
3	ALIGNMENT SCREW	1

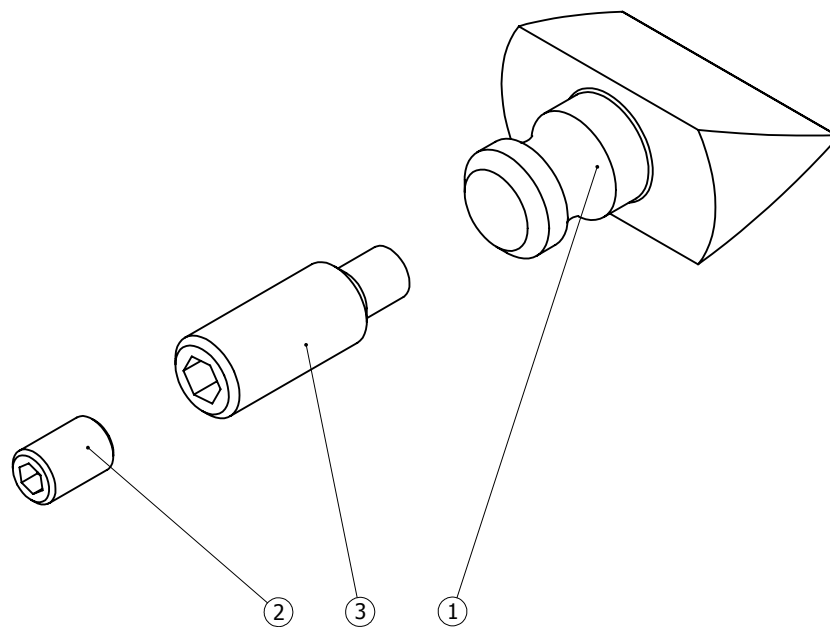

NS12 CUTTING TIP SERVICE KIT (3x)

1075300-01-01 REV.02

ITEM NO.	DESCRIPTION	QTY
1	NS12 CUTTING TIP	3
2	M4 x 6mm Grub Screw	3
3	ALIGNMENT SCREW	3

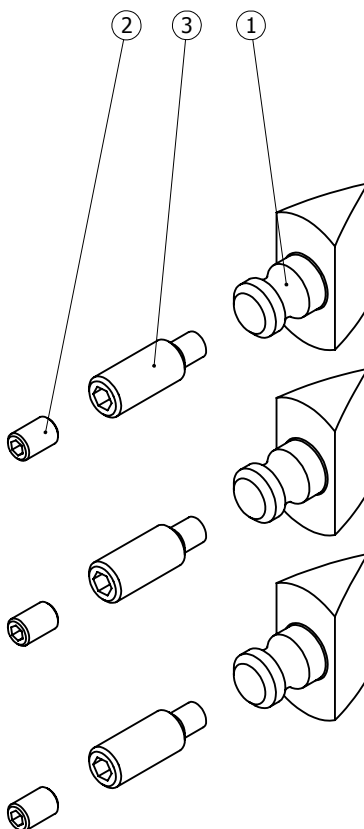

NS15 CUTTING TIP SERVICE KIT (1x)

1005100-01-01 REV.02

ITEM NO.	DESCRIPTION	QTY
1	CUTTING TIP	1
2	M4 x 6mm Grub Screw	1
3	ALIGNMENT SCREW	1

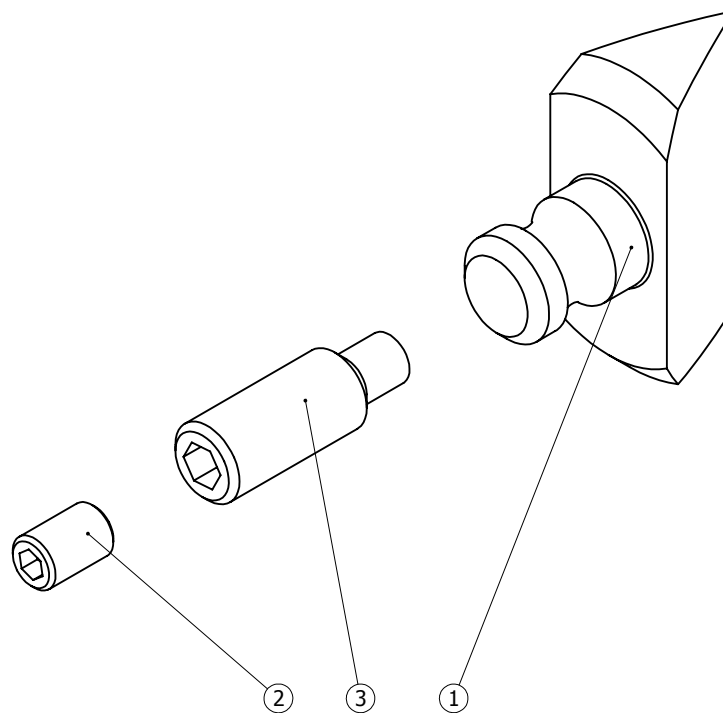

NS15 CUTTING TIP SERVICE KIT (3x)

1005300-01-01 REV.02

ITEM NO.	DESCRIPTION	QTY
1	CUTTING TIP	3
2	M4 x 6mm Grub Screw	3
3	ALIGNMENT SCREW	3

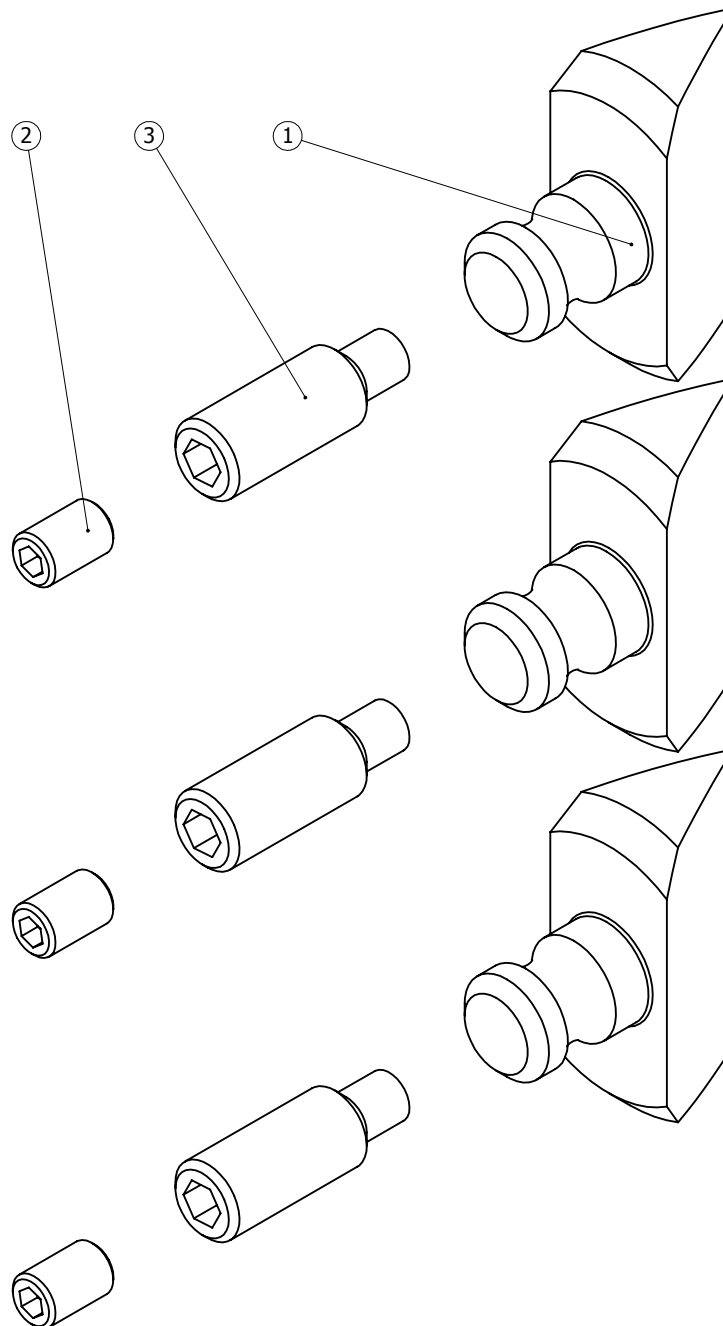

NS20 CUTTING TIP SERVICE KIT (1x)

1025100-01-01 REV.02

ITEM NO.	DESCRIPTION	QTY
1	CUTTING TIP - COATING	1
2	M5 SCKT SET SCREW	1
3	ALIGNMENT SCREW	1

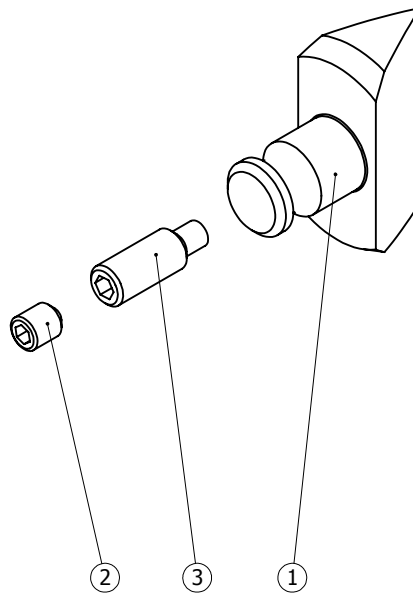

NS20 CUTTING TIP SERVICE KIT (3x)

1025300-01-01 REV.02

ITEM NO.	DESCRIPTION	QTY
1	CUTTING TIP - COATING	3
2	M5 SCKT SET SCREW	3
3	ALIGNMENT SCREW	3

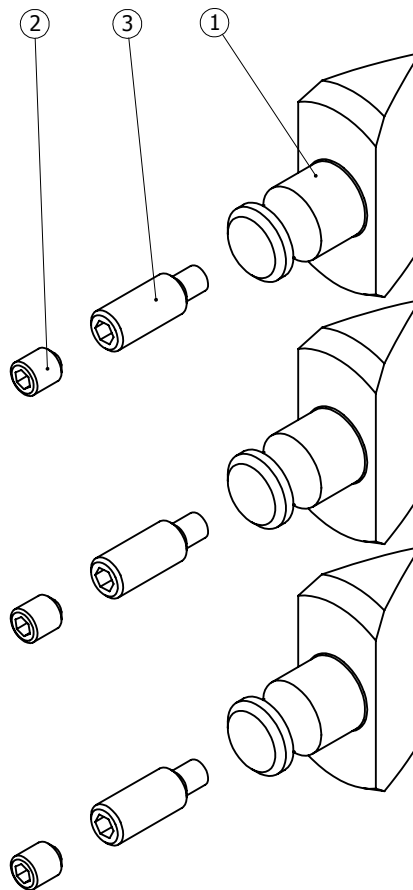

NS36TE TIP SERVICE KIT (QTY 1)

1035100-01 FIRST ISSUE

ITEM NO.	PART NO.	DESCRIPTION	QTY.
1	1032000-01	CUTTING TIP - INSPECTION	1
2	1032700-01	ALIGNMENT SCREW	1
3	1033700-01	M8 x 10mm GRUB SCREW	1

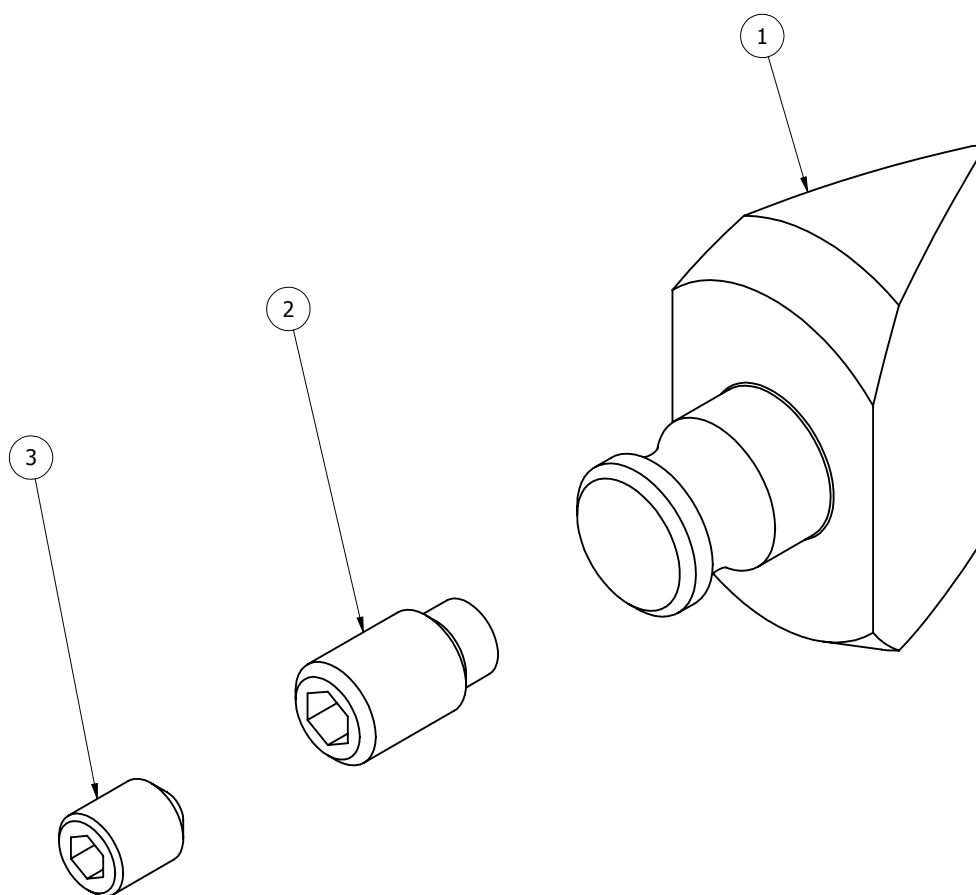

NS36TE TIP SERVICE KIT (QTY 3)

1035300-01 FIRST ISSUE

ITEM NO.	PART NO.	DESCRIPTION	QTY.
1	1032000-01	CUTTING TIP - INSPECTION	3
2	1032700-01	ALIGNMENT SCREW	3
3	1033700-01	M8 x 10mm GRUB SCREW	3

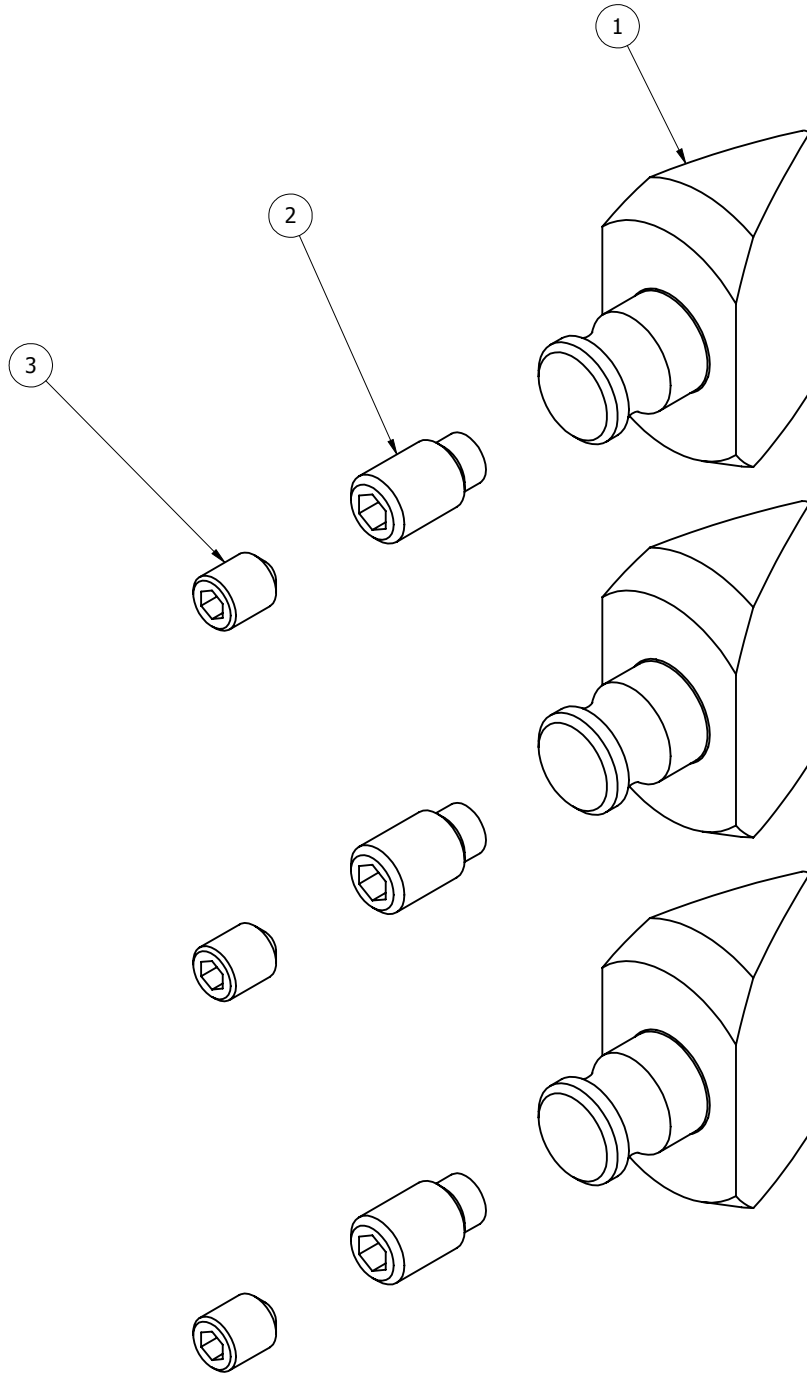

SAFETY BOND
830080-01 REV.01

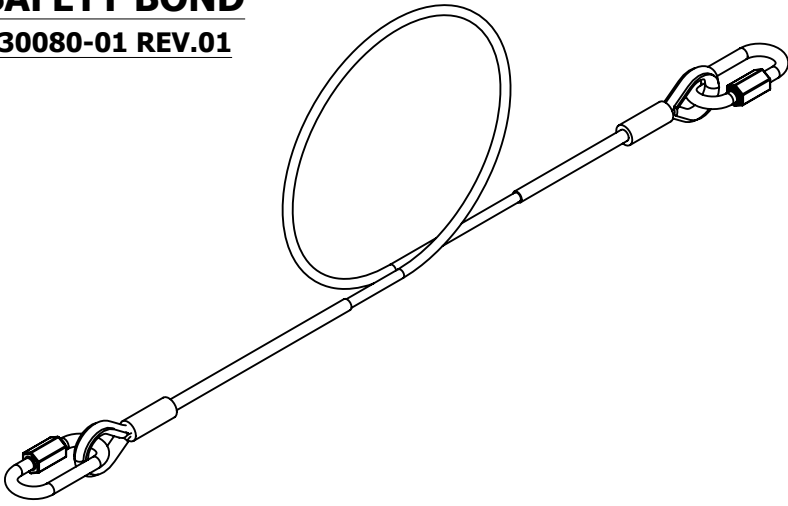



EQUALIZER INTERNATIONAL LTD.

**Head Office
Equalizer House
Claymore Drive
Aberdeen
Scotland
UK**

**AB23 8GD
t: +44 (0) 1224 701970
f: +44 (0) 1224 823791**

**Houston Office
1330 Yale Street
Houston TX 77008
USA**

t: +1 (713) 927-1840

www.equalizerinternational.com