



# Health & Safety, Operating and Maintenance Instruction Manual



## Multi-Stage Tensioner TTM-M030-21-00



**Job Number:** Q6936

**Date:** June 2012



# **BOLTIGHT<sup>®</sup>**

**HYDRAULIC BOLT TENSIONING**



## **Copyright Statement & Disclaimer**

This Health & Safety, Operating and Maintenance Manual has been prepared by the company, Boltight Limited. All of the material in this manual is the property of the company and is subject to copyright. No part of this manual may be copied or reproduced without the prior written consent of the company.

Please note that the scope of this document covers the safety, operation and maintenance instructions concerned with the equipment supplied ONLY. Safe handling, usage and storage of this equipment on customer applications and installations is the responsibility of the customer. This document should only be considered a part of the customer's wider procedure for installation of plant and therefore Boltight cannot accept any responsibility for any actions arising as a result of misuse of this equipment.

The contents of this manual may periodically be subject to alteration. Boltight Ltd reserves the right to alter or modify this manual without prior notification.

Further copies of this manual may be purchased from Boltight.

Boltight Limited,  
Unit 2, Junction 10 Business Park,  
Bentley Mill Way,  
Walsall WS2 0LE,  
West Midlands  
UK

Tel +44 (0)845 500 5556  
Fax +44 (0)845 500 5557  
Email [sales@boltight.com](mailto:sales@boltight.com)  
Web [www.boltight.com](http://www.boltight.com)

## **Foreword**

Thank you for purchasing or renting Boltight Bolt Tensioning Equipment.

Before using the bolt tensioning equipment you are advised to study this operating manual carefully.

Boltight Limited is an ISO9001 company and the bolt tensioning equipment has been designed to comply with the European Pressure Equipment Directive and is CE marked. However the pressures and forces involved with the use of this equipment are high and it is imperative that use users of the equipment read and understand the operating manual, paying particular attention to the safety information in Section 2.0.



## **Contents**

### **Technical Information**

*European Pressure Equipment Directive*

*General Description*

### **Health & Safety**

*Important Notice*

*Quick Connectors*

*Bolt Tensioning Tools*

### **Operating Instructions**

*Introduction*

*Tool Description*

*Stroke Indicator*

*Tightening a Bolt*

*Loosening a Bolt*

### **Maintenance & Storage**

*General Information*

*Storage*

*Maintenance*

### **Specification**

*Oil Pressure vs Theoretical Tensioning Force Graph*

*Tool Specification*

*General Arrangement Drawing*

*Important Information*

### **Section 1**

*Page 01*

*Page 01*

### **Section 2**

*Page 01*

*Page 02*

*Page 02*

### **Section 3**

*Page 01*

*Page 02*

*Page 02*

*Page 04*

*Page 18*

### **Section 4**

*Page 01*

*Page 01*

*Page 01*

### **Section 5**

*Page 01*

*Page 02*

*Page 03*

*Page 04*



# **Section 1**

## **Technical Information**





## European Pressure Equipment Directive

The BOLTIGHT typhoon range of hydraulic bolt tensioning tools have been designed to operate at pressures up to 1500 bar with Group 2 liquid (hydraulic oil ISO10) and volume less than 10 litres.

This equipment falls into category 1 of the specified pressure volume thresholds. Under the regulations the equipment must therefore:-

- a) be safe
- b) meet the essential safety requirements covering design, manufacture and testing
- c) satisfy the appropriate conformity assessment procedure
- d) be accompanied by adequate instructions for use
- e) be marked to identify the manufacturer and CE marked

The hydraulic cylinder has been pressure tested at 10% above its maximum operating pressure and a test certificate has been issued.

## General Description

The pressure equipment covered by this operating manual is a multi-stage hydraulic bolt tensioning tool. The tensioner comprises two axially-stacked interlocking load cells (each comprising a body, piston, inner/outer seal and reaction nut), a common central puller bar with ½" drive socket, a spring retraction mechanism and interconnecting bridge. The bridge incorporates a spring-loaded gear-driven nut rundown mechanism for convenience, also incorporating a ½" drive socket.

The load cells are pressurised via a radial manifold block, using a CEJN 116 high pressure nipple. Each load cell is fitted with hybrid composite plastic and rubber hydraulic seals. The user must ensure that the hoses and pumps utilised to pressurise the tool are suitable for compatibility with the bolt tensioners supplied, and also rated for safe usage at or above the tools maximum operating pressure. Where in doubt the operator must contact Boltight for further information.

Within the tensioner, the upper and lower Hydraulic Load Cells are interlocked for simultaneous pressurisation and are supported by the Bridge. Both load cells engage a common puller bar, whose design has been configured in conjunction with the Bridge design to provide optimum engagement with the customer's application. Tensioning applications can be used with standard hex nuts, large width hex nuts, round nuts or special nuts. The correct tool must be selected in accordance with the application. The gear driven socket within the bridge has been designed to interface snugly with the across flats dimensions of hex nuts as supplied by the customer, and nut rundown following pressurisation is achieved by rotating the gear driven socket. This is performed via the ½" square drive socket located at the top of the gearbox. This gearbox and geared socket mechanism can also be utilised to unwind nuts during de-tensioning procedures.

Before handling check the unit weight in section 5. If it is less than 20kg then it can be handled manually. Larger tools should not be lifted by hand.

The different sizes of Multi Stage tools have different maximum strokes. Refer to the information in section 5 to confirm the maximum stroke of the model supplied. A visual indicator ring mounted near the top of the puller allows the operator to determine when this maximum stroke has been reached. Although the tensioner has been designed with a positive stop to prevent over-stroking, the tool should never be over-stroked beyond its maximum working pressure. Whenever the visual indicator ring can be seen protruding through the top of the tool, the operator should immediately shut-off the pump and reset the tool to zero stroke before tensioning/detensioning is resumed (see Section 3 for full instructions).

The tool features a spring-actuated piston return facility. The spring retraction system comprises heavy duty springs, which are contained within the spring cap. The spring system should not require attention during the working life of the tool. When the pressure within the tool is returned to zero the spring force will retract the pistons fully back into the outer bodies. As mentioned above, care should be taken not to stroke the tool beyond its maximum stroke.

The tool also features a safe failure mechanism. In the event that the fatigue life of the tool expires, it has been engineered to fail safely and remain in-situ upon the bolt, posing no threat to adjacent personnel or equipment.

The maximum tool pressure cycles is indicated with the tool technical data. A record of pressure cycles should be kept and the tool returned for puller replacement before reaching this limit. A cycle counter can be fitted to the tensioner, to assist with quantifying the number of cycles the tool has experienced.

The tensioner must not be modified by any type of machining and no attachment can be made to the tools by any form of welding or brazing.

The tensioner has been subjected to a one-off pressure test prior to despatch, and a test certificate has been issued to certify this. Please note that this is not the maximum operating pressure and it is strongly advised that the tool is NEVER operated above its maximum operating pressure. The tool does not require re-testing during its working life, even after fitting new sealing elements. If the user wishes to conduct a pressure test, the tensioner should be returned to the manufacturer's works for recertification.

# **Section 2**

## **Health & Safety**

**Persons using hydraulic bolt tensioning tools must read and understand this section before starting to use the equipment. Your attention is particularly drawn to the instructions in RED on Page 2 and Page 5**



## Important Notice



THINK SAFETY

Thank you for purchasing or renting your hydraulic bolt tensioning equipment from **Boltight**. Bolt tensioning tools are very powerful and capable of inducing very high bolt stresses. This equipment has been designed to give many years of safe tightening of bolted connections when used in accordance with these instructions.

Persons using hydraulic bolt tensioning tools must be properly trained in the correct use of the equipment and must also take adequate steps to ensure their own safety, and the Health and Safety of others working in the area where bolt tensioning operations are being performed. **Boltight** will be pleased to quote for the provision of training courses either at its UK base or on site anywhere in the world.

Operators must read all of this instruction and maintenance manual before attempting to use the equipment. Do not use the equipment if you are not already an experienced user of hydraulic bolt tensioning tools or if you have not already received proper training. Your attention is particularly drawn to the notes in **RED**.

**When tightening/loosening bolts using tensioners, extremely high loads are induced. If the bolt material is incorrectly specified or the bolt has been subjected to any damage, it is possible that the bolt may shear. This could also occur if the tool is incorrectly installed (i.e. if there is insufficient thread engagement between the tensioner and the bolt). In these scenarios the tool could be launched at high speed along the axis of the bolt. This is an extremely rare occurrence provided that procedures are followed correctly, however in the event of failure anyone standing in line with the axis of the bolt during the tensioning operation will suffer critical injury or even be killed. It is therefore essential that anyone operating this equipment is properly trained in its safe use and takes every precaution to ensure that nobody is allowed to stand, work or stray near to or into line with the axis of any bolt tensioning tool during the bolt tensioning operation.**

Bolt tensioning tools are powerful and when using high pressure hydraulics it is essential that you are trained in the correct use of the equipment and adhere fully with the Health and Safety Instructions.

## Quick Connectors



**DO NOT** pressurise the connectors when they are disconnected.

Check there is no pressure in the system before attempting to connect or disconnect the couplings.

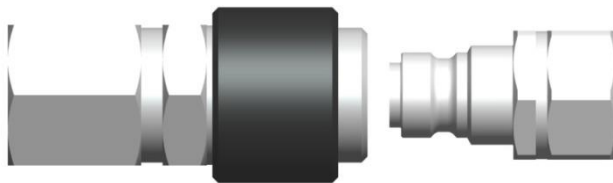
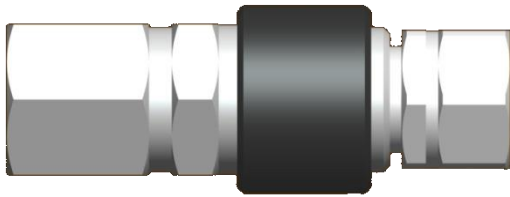

## Bolt Tensioning Tools



**DO NOT** exceed the tools Maximum Working Pressure. (This information can be found in section 5)

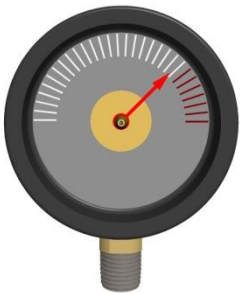

**$\leq$  Maximum**

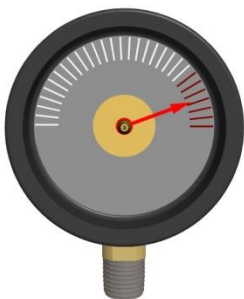

**$>$  Maximum**





DO NOT pressurise the bolt tensioning tool unless it is attached to a fully engaged bolt.

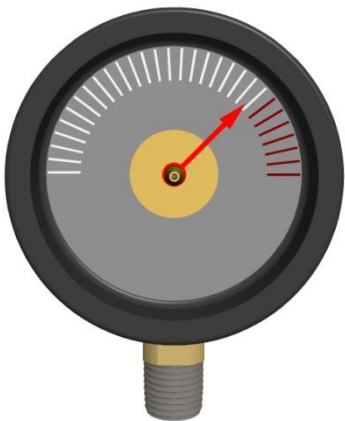
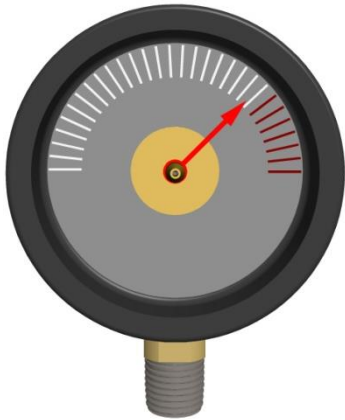



Bolt tensioning tools **MUST** always be used with a hydraulic pump which has a pressure limiting device. Always check that the pump stall pressure is set at or below the maximum working pressure for the tool being used.



Clear all personnel from the area where the bolt tensioning operation is to be performed. Position the pump a safe distance away from the bolt tensioning tools. Set up barriers and warning signs, or make other adequate arrangements to prevent unauthorised personnel from accidentally straying into the bolt tensioning area.



**Ensure that nobody is allowed to stand near to a bolt tensioning tool during pressurisation. At no time should anyone allow any part of their body to be positioned over the bolt axis of a bolt tensioner whilst the pressure is rising or when it is pressurised.**



**Do not approach a bolt tensioning tool whilst it is being pressurised. Remember that a damaged bolt or tool is most likely to fail at this critical time. When the operating pressure has been reached, approach a pressurised bolt tensioning tool only for as long as is necessary to rotate the ring nut. Ensure that when rotating the nut you are well outside of the tensioners vertical axis.**



Never leave a pressurised bolt tensioning tool unattended. Keep the bolt tensioning tools under pressure for the minimum time necessary to complete the bolt tightening operation.



Always ensure adequate PPE (Personal Protective Equipment) is worn by all personnel using bolt tensioning tools. **SAFETY GLASSES** and **GLOVES** are essential. **OVERALLS** and a **HARD HAT** are recommended.



The equipment supplied should only be used as intended (i.e. as a bolt tensioning tool). **DO NOT** use the tools as hydraulic jacks or for any other purpose.



Do not pick up or carry bolt tensioning tools using flexible hydraulic hoses as a handle.



Do not try to tighten a leaking hydraulic connection when it is under pressure. First release the pressure, then repair the leak.



**NEVER** touch a hydraulic hose under pressure or allow it to rest across any part of the body. Do not pressurise a hydraulic hose if any person is or is likely to come into contact with it during pressurisation. If it requires moving or repositioning, **ALWAYS** release the pressure beforehand.



# **Section 3**

## **Operating Instructions**



## Introduction

A hydraulic bolt tensioning tool provides a quick and easy method for tightening large diameter bolts to high and accurate pre-loads. Unlike conventional methods, it does not use torque and does not require any forceful turning of the nut or bolt (as is the case using impact wrenches, flogging spanners or hydraulic torque wrenches). All of these methods have one common drawback: FRICTION. Overcoming thread friction and friction between the nut and the washer uses up over 80% of the torque energy applied to the nut or bolt, leaving less than 20% of the energy to produce useful tension in the shank of the bolt. Variations in this friction loss from bolt to bolt causes non-uniform tension in bolts that have been tightened to the same torque or impact wrench setting.

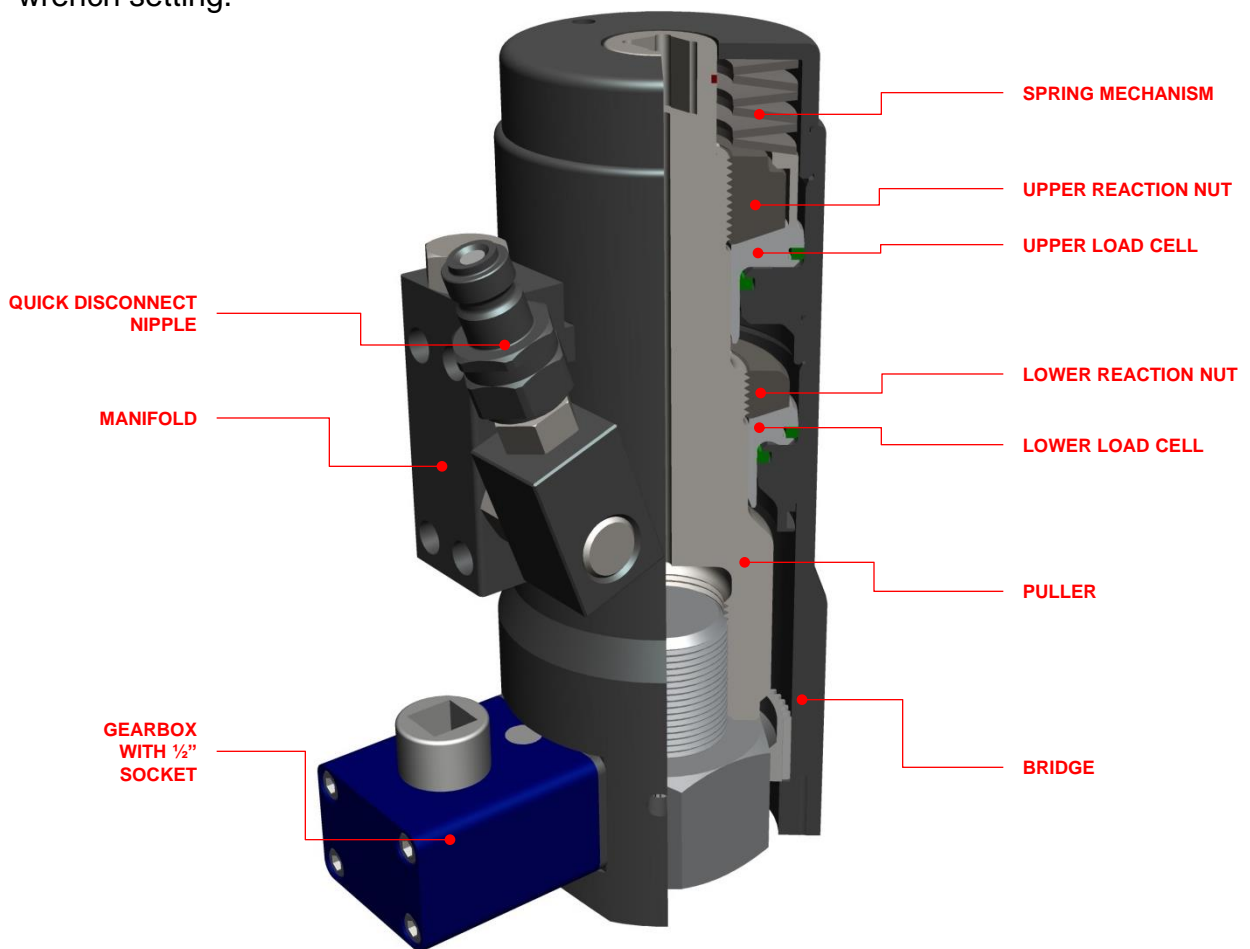

A hydraulic bolt tensioner is an annular jack which fits over the bolt and nut to be tightened. The jack pushes against the bolted joint and pulls on the end of the bolt, which typically needs to be at least one diameter longer to accommodate the bolt tensioning tool (although this varies according to the load and bolt material specified). Because the tensioner force produced is applied directly to the end of the bolt, a tension equal to the load generated by the tensioner is developed in the shank of the bolt. With the tool applying this tension, it is possible to turn the nut with zero torque until it is tight. The load applied by the tensioner is then relaxed and a known percentage (depending on the length of the bolt and its diameter) is retained within the bolt. This proportion of load retained is usually very high; thusly tensioning method offers significantly better efficiency as well as accuracy compared to other bolt tightening methods.

Bolt tensioning tools can be grouped to enable multiple bolts to be tightened simultaneously, to the same high and accurate pre-load. This is particularly useful when compressing gaskets in pipeline or pressure vessel flanged connections. The high load developed by the multiple bolt tensioning tools is evenly distributed around the joint causing the gasket to flow into the surface irregularities of the flange, resulting in a much better seal.

Flexible hoses with self sealing quick disconnect couplings are used to connect the bolt tensioning tools together to form a hydraulic ring main. The ring main and tensioning tools are usually pressurised using an air driven pump working from a compressed air supply, although hand pumps are also permissible.

## **Tool Description**

The Typhoon Multi-Stage Range has been engineered to provide maximum load capacity under minimal radial envelope conditions.

A multi-stage bolt tensioning tool comprises two axially-stacked interlocking load cells (each comprising a body, piston, inner/outer seal and reaction nut), a common central puller bar with ½” drive socket, a spring retraction mechanism and interconnecting bridge. The bridge incorporates a gear-driven nut rundown mechanism for convenience, also incorporating a ½” drive socket. The tensioner incorporates a mechanical anti-overstroke protection facility, and also features a maximum stroke indicator. The load cells are pressurised simultaneously via a radially mounted manifold block of vertical CEJN 116 nipple configuration.

The maximum operating pressure, maximum force and maximum stroke for the equipment are all listed in the Specification section (section 5).

## **Stroke Indicator**

The diagram on the next page shows the stroke indicator. The operator is alerted that maximum stroke has been achieved by the indicator ring which is mounted in the shaft of the puller .

When the tool reaches maximum stroke; i.e. when this indicator is visible to the operator, the operator should stop the pump and tighten the nut. No further benefit is gained by increasing the pressure at maximum stroke as the bolt cannot be stretched any further.

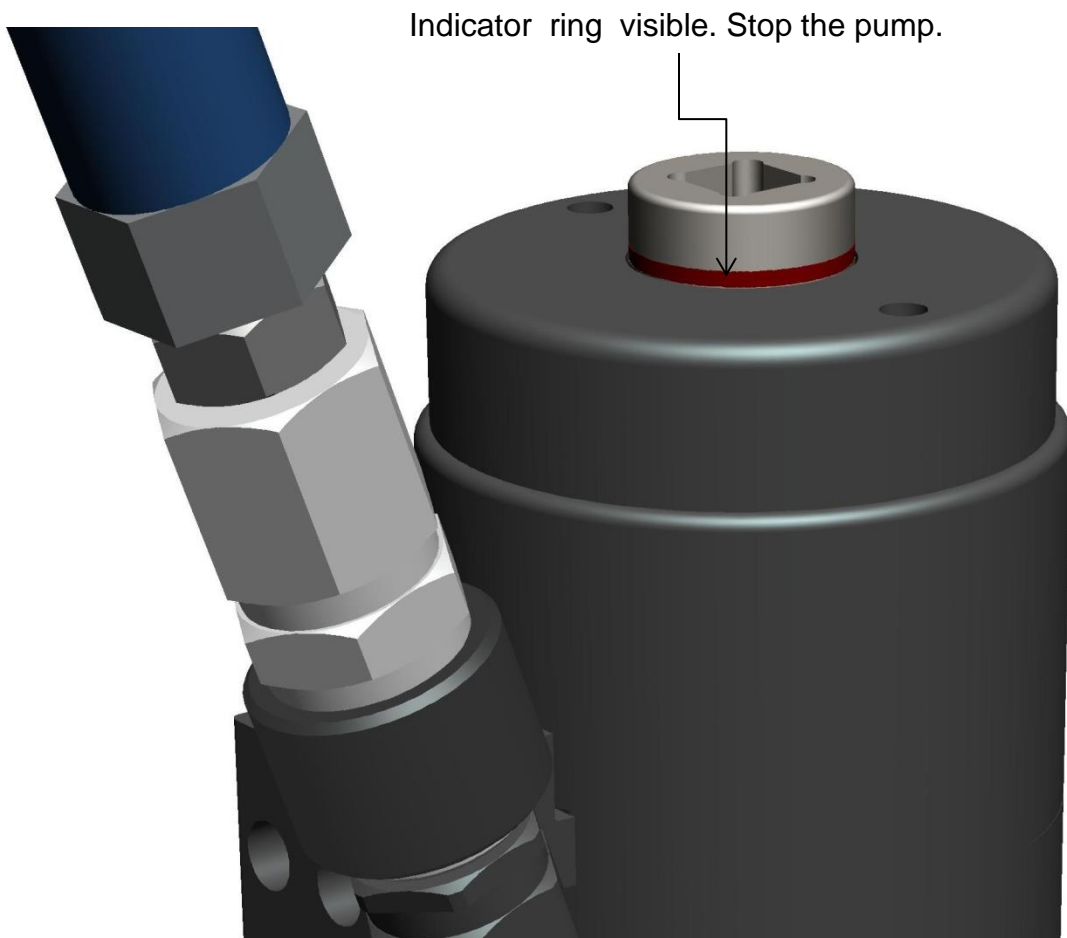
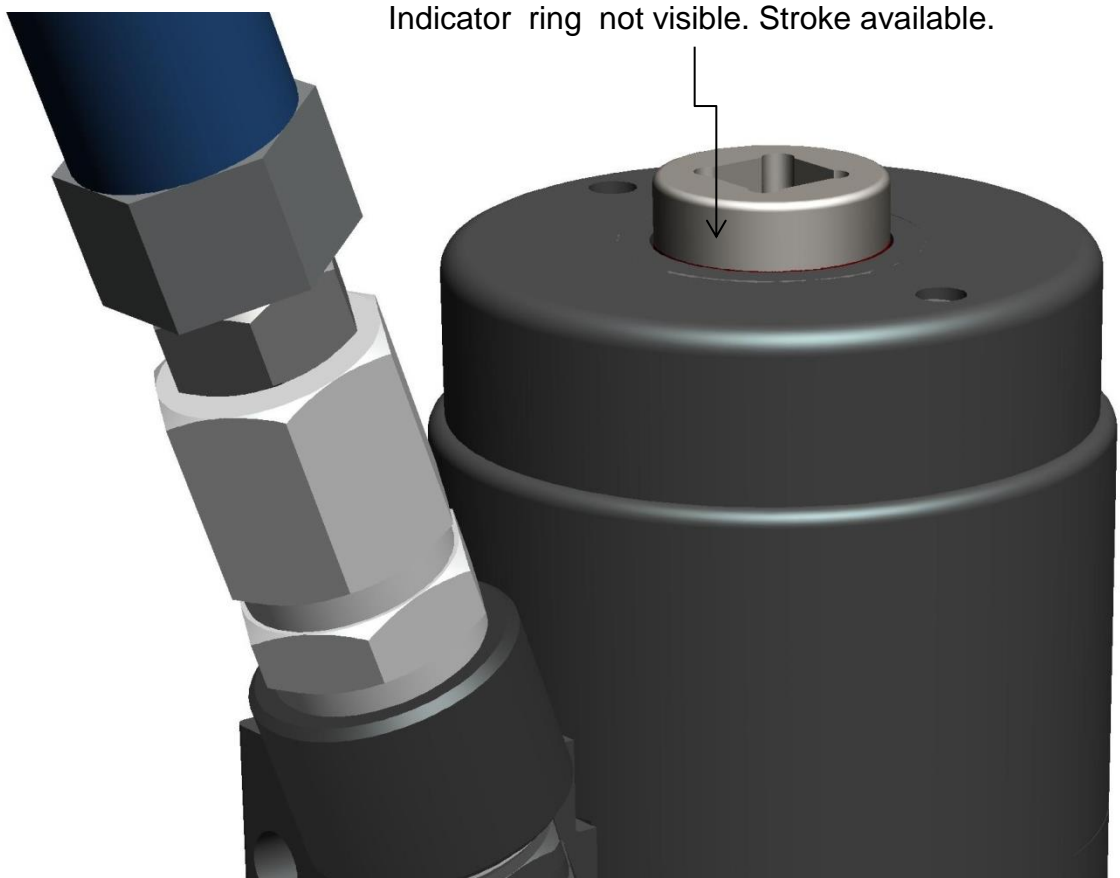

## Step 1 – Tightening a Bolt

Before commencing the bolt tensioning operation read and comply with all of the Health & Safety Instructions in Section 2. Operators should also be familiar with the 'Important Information' literature in Sections 1 and 5.

## Step 2 – Tightening a Bolt

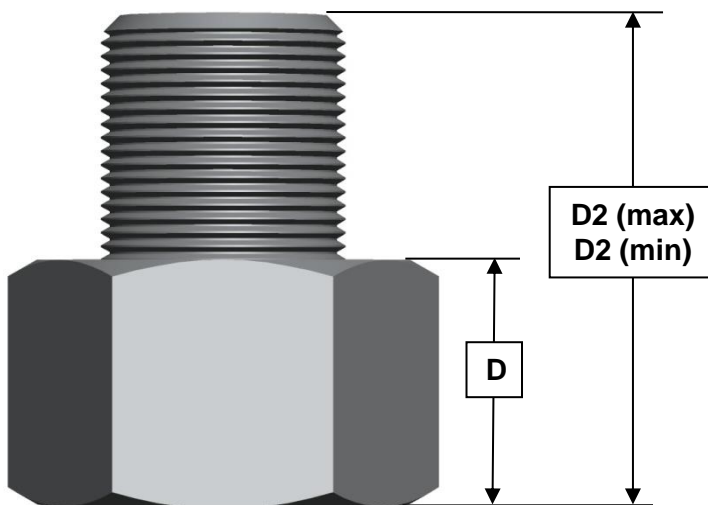

Ensure that at least D2 (min) of the bolt is protruding. The nut and washer protrusions, "D", must also be in accordance with the information in section 5.



Either the stud protrusion is too short or the nut is too high up the bolt. Engagement with the Tensioner is insufficient – the bolt threads may strip and cause injury.

### Step 3 – Tightening a Bolt

Position the Tensioner over the bolt to be tightened.

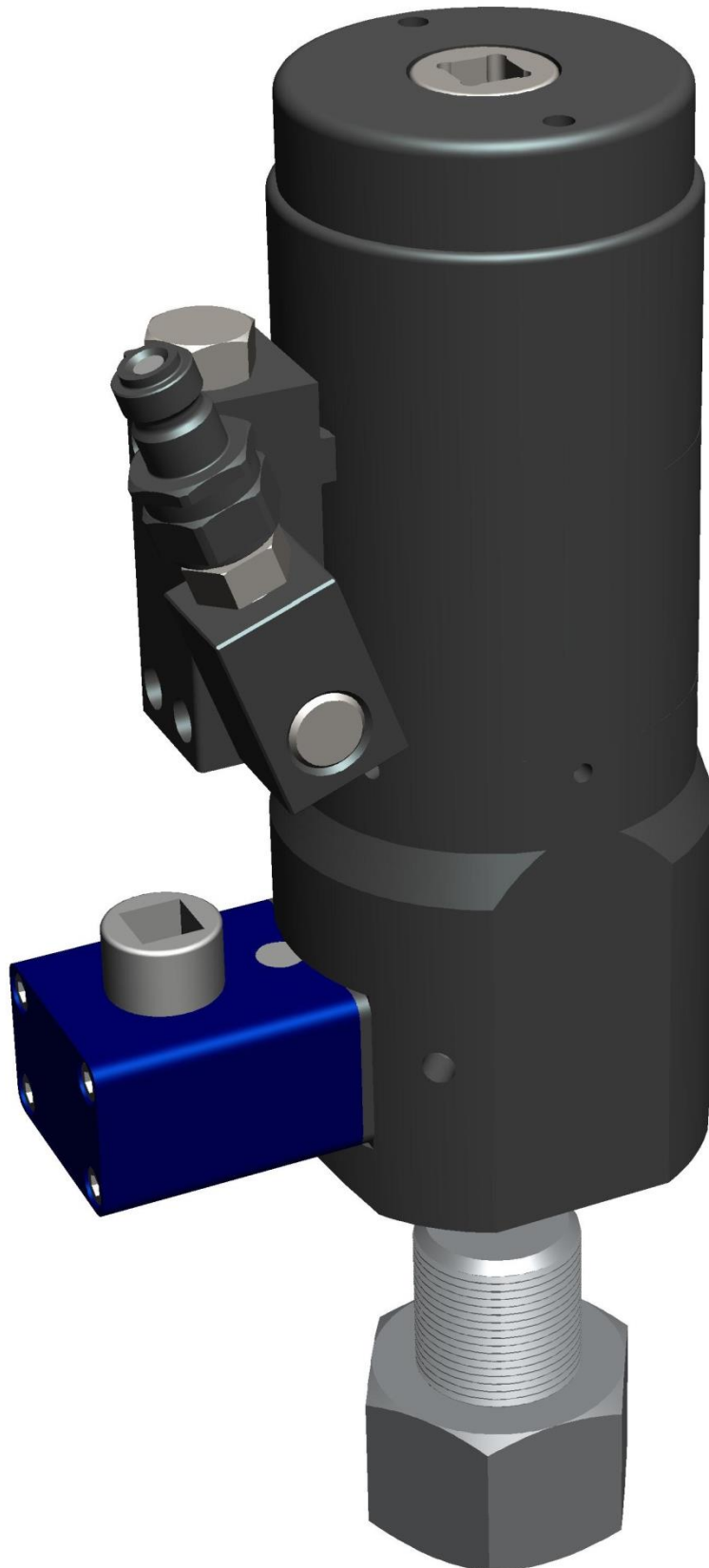

## Step 4 – Tightening a Bolt

Engage the Puller with the bolt. A 1/2in Square Socket is provided in the top of the Puller Bar so that the Tensioner orientation can be maintained whilst the Puller engages the bolt.

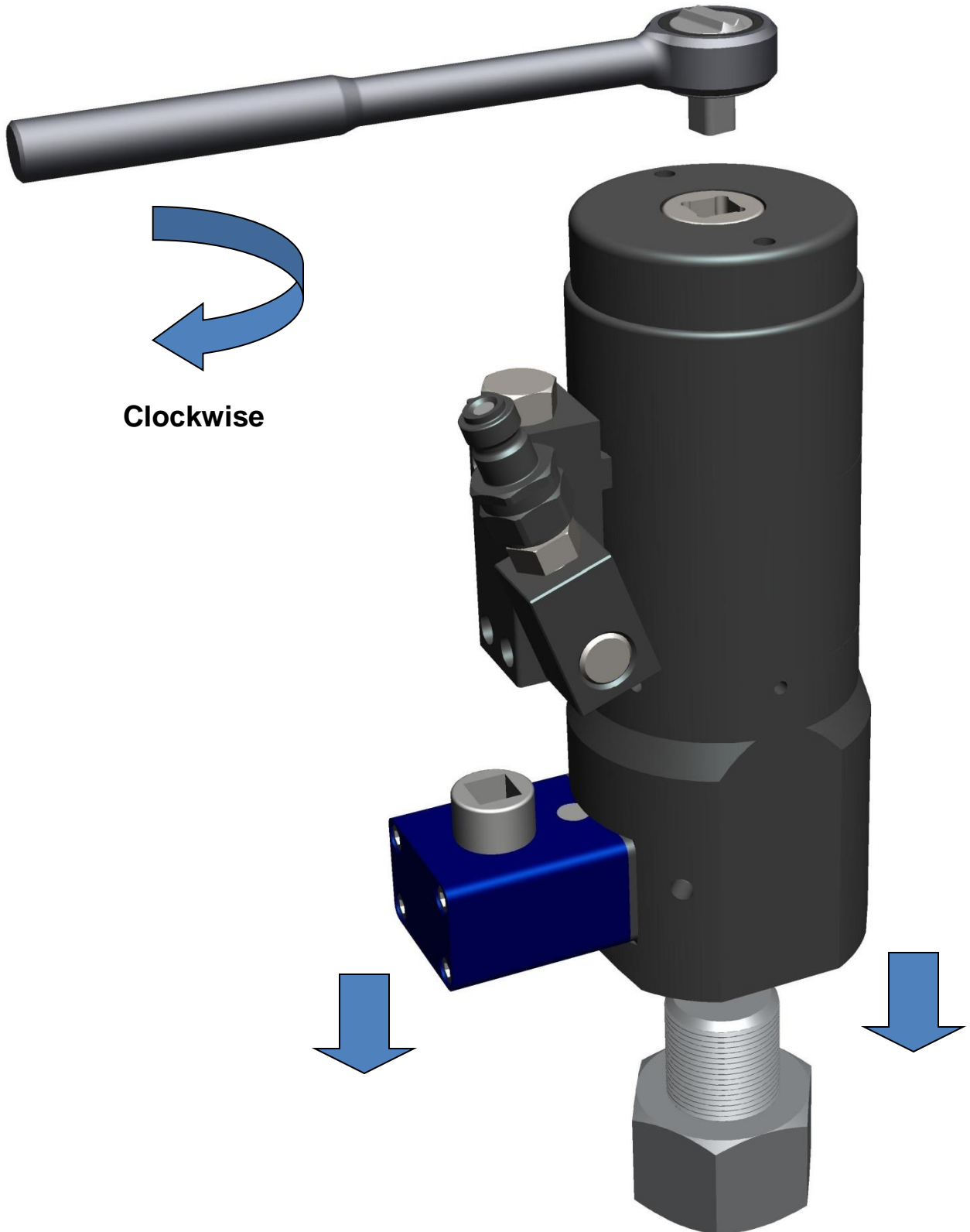



Continue rotating the Puller, increasing its engagement with the bolt until the bridge is flush with the washer. To ensure the tool is fully flush, it may be necessary to rotate the gearbox slightly whilst lowering to fully engage the gear driven socket with the nut.

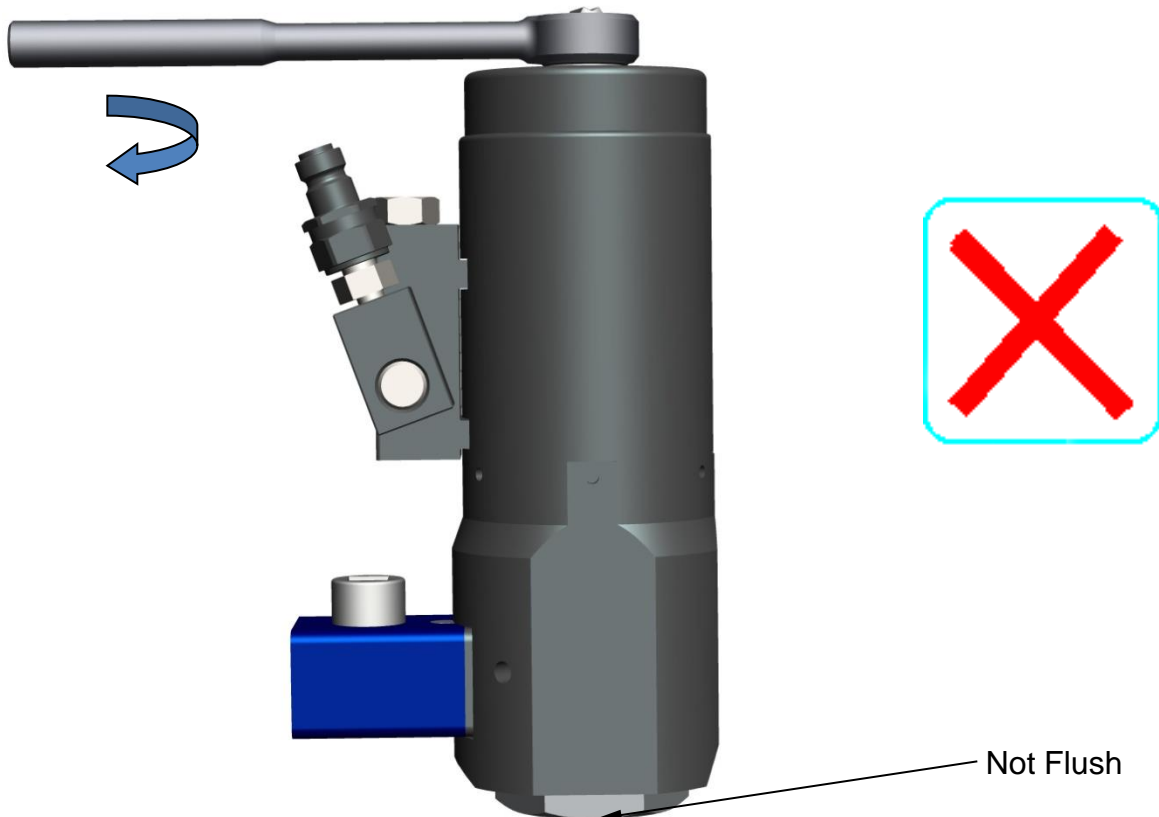
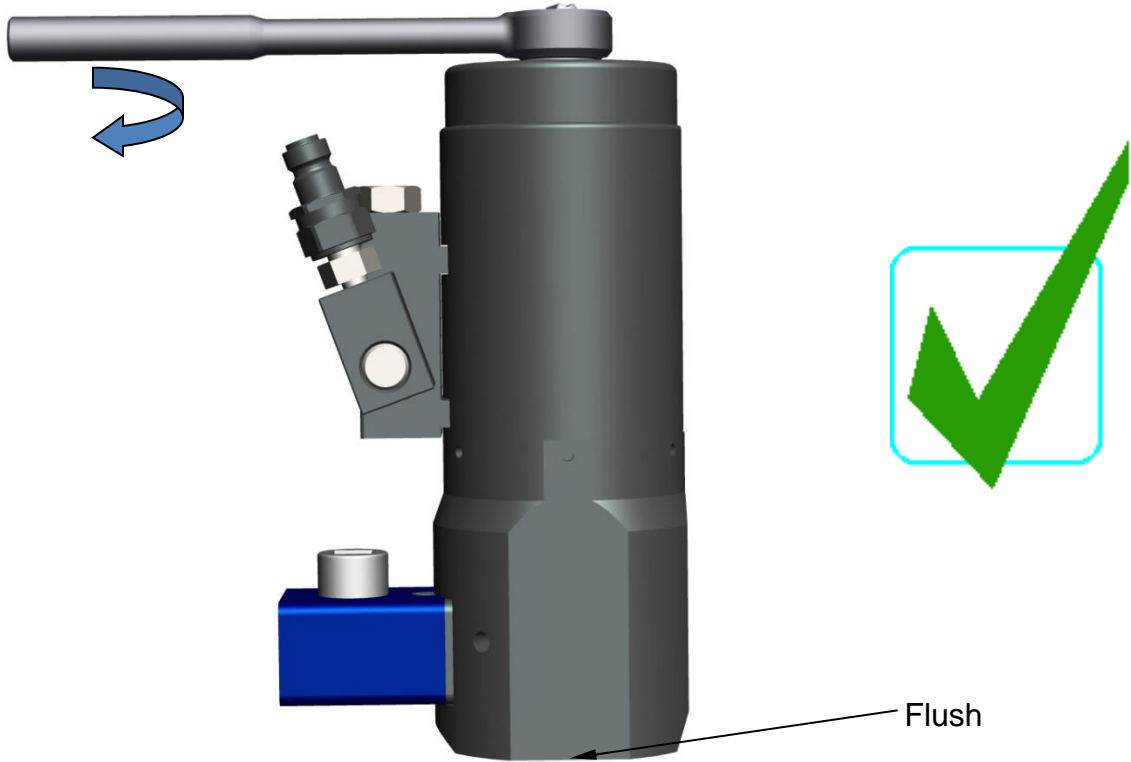

Once the Tensioner is in situ, it should still be possible to rotate the bridge to a suitable angle to access the bolt if required.

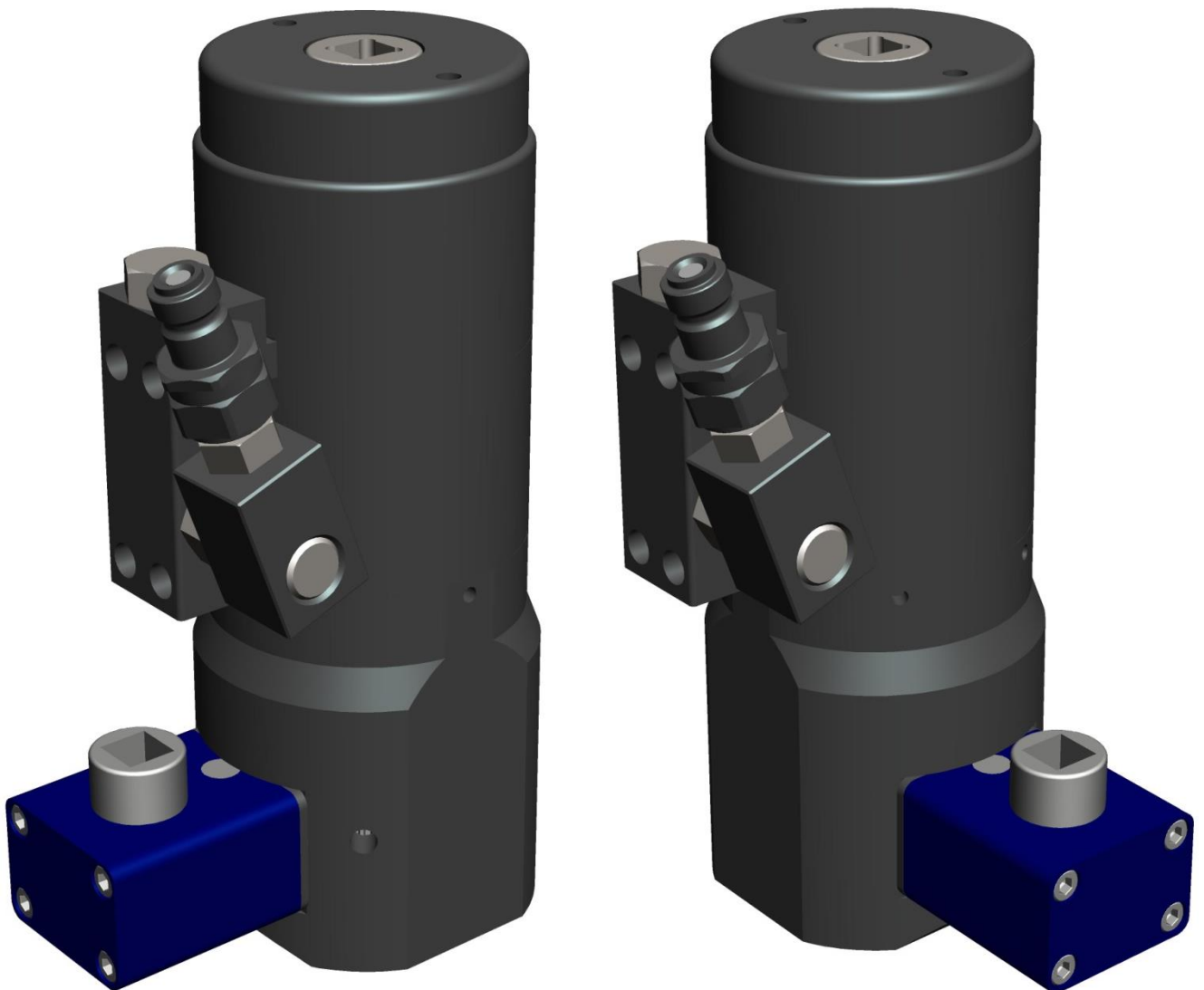

## Using Quick Connectors

Before using Quick Connectors the operator should ensure that they have read and understood the Quick Connectors Health and Safety instructions in section 1. To connect the Quick Connect Coupling and Nipple, first check there is no pressure in the system. Then pull back the shroud by hand and push the coupling onto the nipple. When together, release the shroud which will spring back to lock the Coupling and Nipple together. To disconnect, first check there is no pressure in the system. Pull back the shroud, by hand, and pull the coupling and nipple apart. Release the shroud when apart.

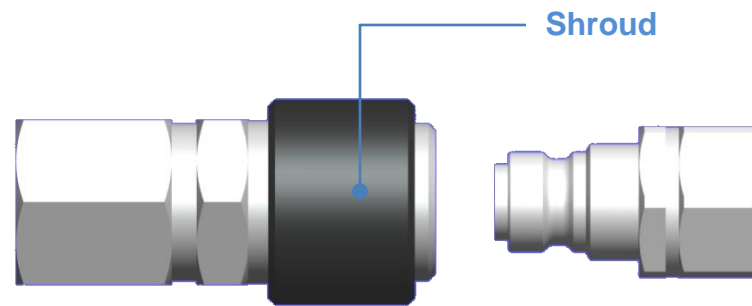

Pull the shroud back to retract.

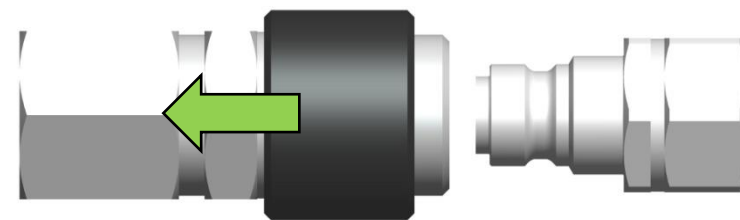

Coupling and nipple with the shroud retracted.

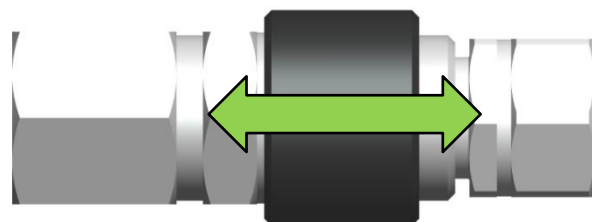

Coupling and nipple pushed together with the shroud retracted.

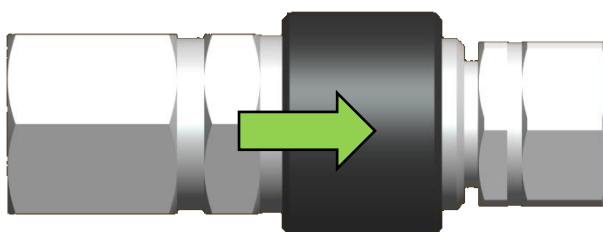

Shroud released, coupling and nipple are now locked together and safe to use.

## Step 5 – Tightening a Bolt

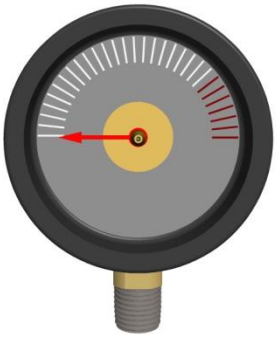

Connect a suitable high pressure hydraulic hose.

Make sure the quick connect coupling is fully engaged.

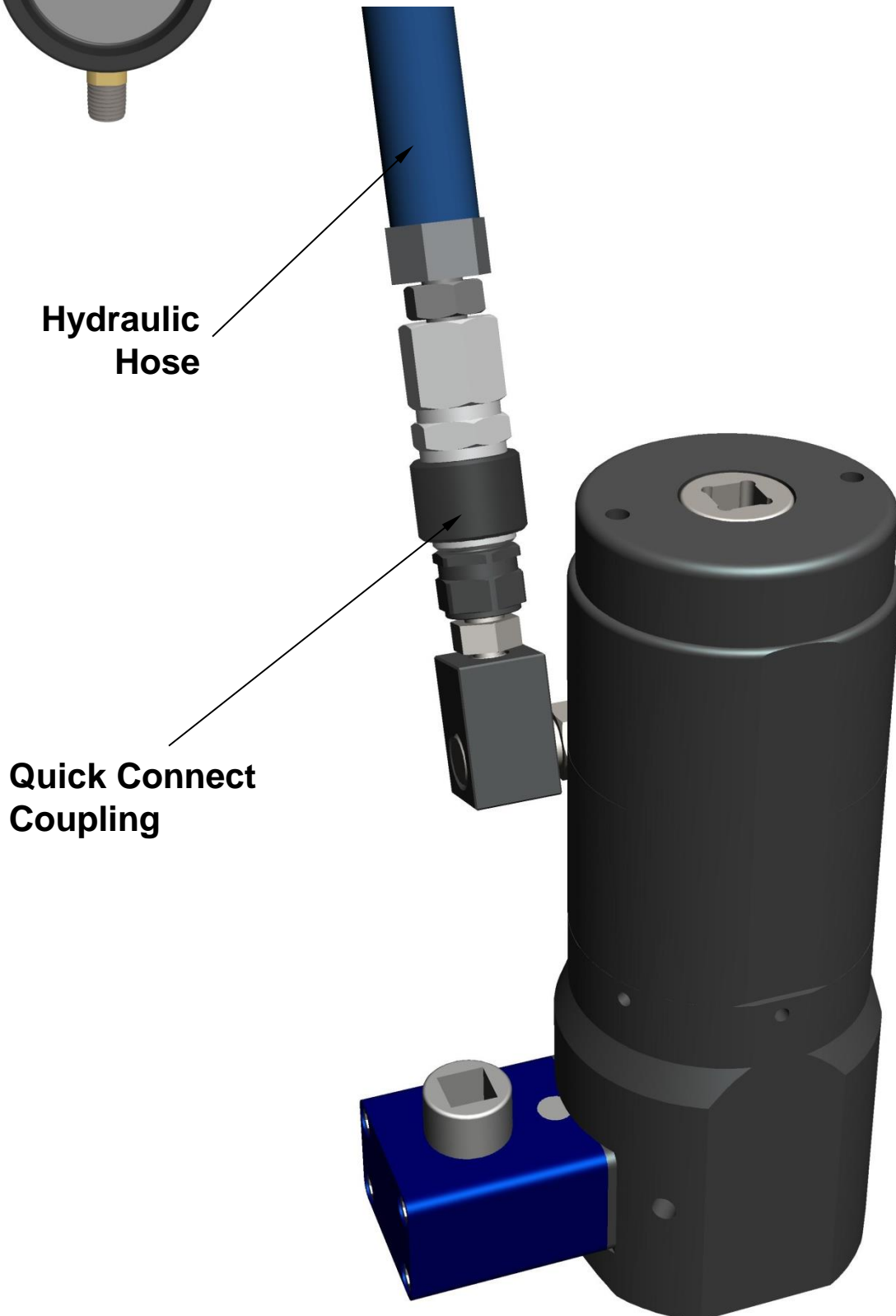

## Health & Safety



THINK SAFETY

The Tensioner is now ready to be pressurised. Before proceeding, operators must familiarise themselves with the Health & Safety Instructions given in this manual, and proceed as follows:-

**Clear all personnel from the area where the bolt tensioning operation is to be performed. Position the pump a safe distance away from the bolt tensioners. Set up barriers and warning signs, or make other adequate arrangements to prevent unauthorised personnel from accidentally straying into the bolt tensioning area.**

**Ensure that nobody is allowed to stand near to a bolt tensioning tool during pressurisation. At no time should anyone allow any part of their body to be positioned over the bolt axis of a bolt tensioner whilst the pressure is rising or when it is pressurised. Do not allow anyone to stand anywhere in or near the axis of a bolt during the tensioning operation.**

**Do not approach a bolt tensioning tool whilst it is being pressurised. Remember that a damaged bolt or tool is most likely to fail at this critical time. When the operating pressure has been reached, approach a pressurised bolt tensioning tool only for as long as is necessary to rotate the ring nut. Ensure that when rotating the nut you are well outside of the tensioner's vertical axis.**

**PPE (Personal Protective Equipment) must be worn by all personnel using bolt tensioning tools. SAFETY GLASSES and GLOVES are essential. OVERALLS and a HARD HAT are recommended.**

**Never leave a pressurised bolt tensioning tool unattended.**

**Release the oil pressure immediately if any unauthorised person moves into the bolt tensioning area and especially if anyone stands in the axis of a bolt being tensioned.**

**Determine the correct working pressure for the bolts to be tightened.**

**Proceed with the following operations keeping the bolt tensioning tools under pressure for the minimum time necessary to complete the bolt tightening operation.**

## Step 6 - Tightening a Bolt



Apply the correct hydraulic pressure. The tool will begin to stroke and the operator should observe the top of the Puller ascending through the top of the tool.



DO NOT exceed the maximum stroke. This is indicated by stroke indicators around the top of the Puller.



DO NOT exceed the maximum operating pressure of the tool.

If the stroke indicators show the tensioner has reached maximum stroke before the correct hydraulic pressure has been achieved, proceed as follows :-

- Go to Step 7 - Tighten the Nut
- Go to Step 8 - Release the Pressure
- Go to Step 9 - Retracting the Tensioner
- Go to Step 10 - Reengage the tool
- Go to Step 6 - Apply the correct Pressure

If necessary repeat this sequence until the bolt tensioning tool reaches the correct oil pressure without reaching the maximum piston stroke.

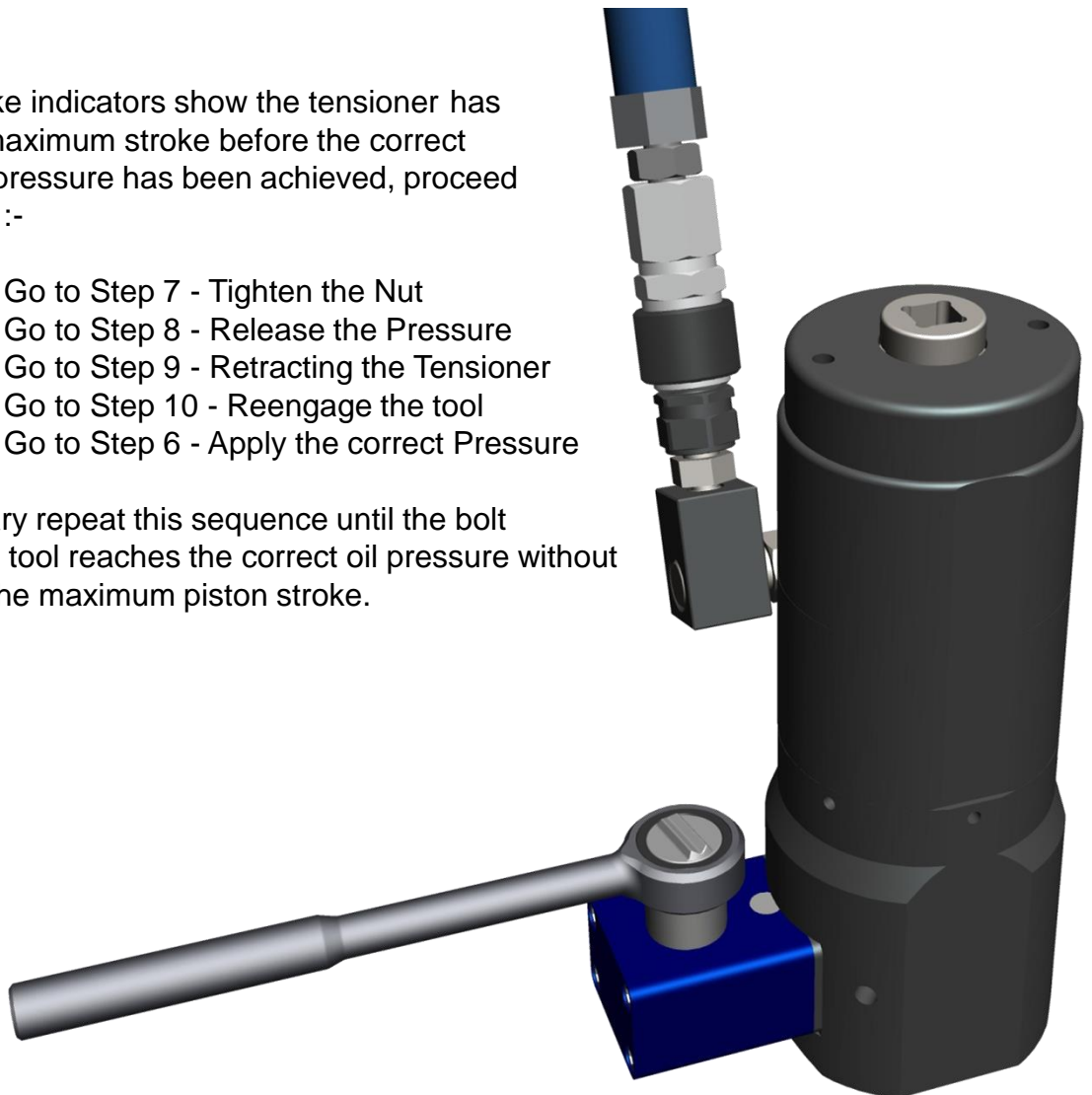

Do not continue increasing the oil pressure when the bolt tensioning tool has reached maximum stroke. Increasing the pressure achieves no increase in bolt tension because no further elongation can be achieved.

## Step 7 – Tightening a Bolt



Use a ½" Drive.

Insert the Drive into Drive Socket on the top of the Gearbox.

Rotate the Socket until the Nut is tight.

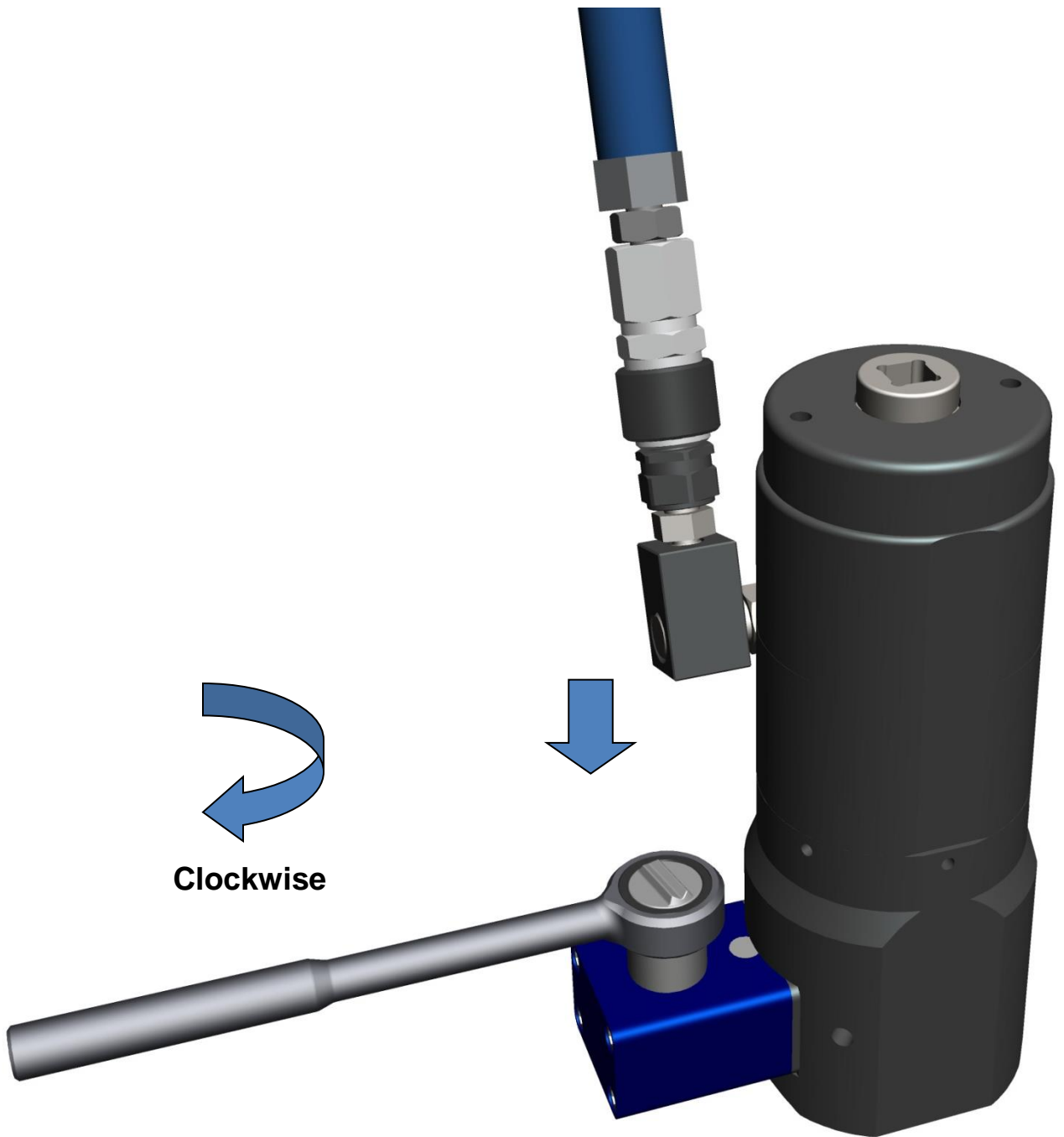

## Step 8 – Tightening a Bolt



Slowly release the hydraulic pressure

## Step 9 – Tightening a Bolt



The spring retract system will now fully retract the tensioning tool.

OPTIONAL - If available, connect a Low Pressure Oil Return Hose. The hose is connected between the tool and the top of the oil reservoir on the air driven pump. This will allow the tool to retract more quickly than if the hydraulic hoses are used.

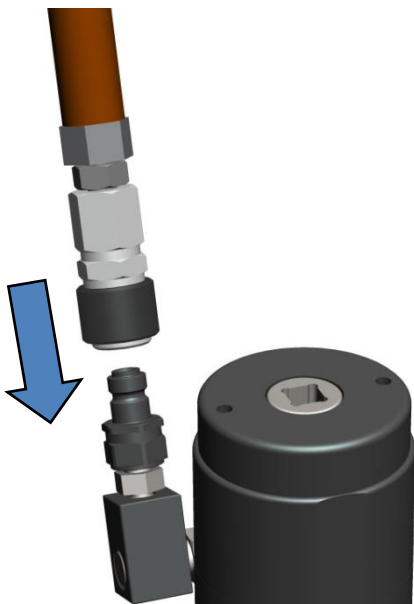
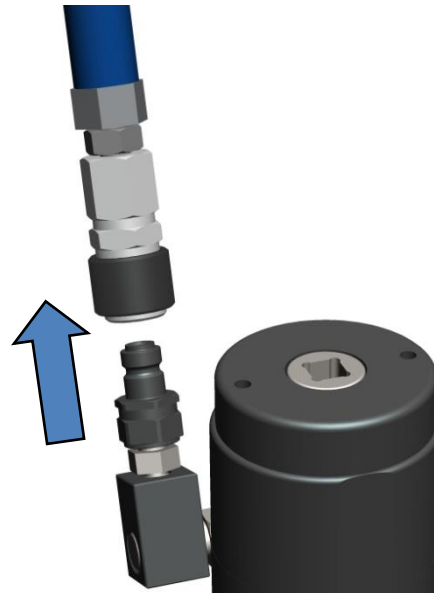



## Step 10 – Tightening a Bolt

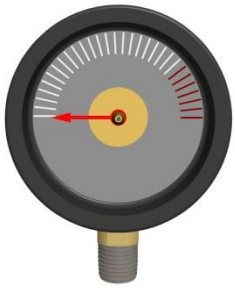

The Tensioner will have retracted upwards since the bolt will have elongated. The tool will need reengaging onto the flange.

Using the 1/2in Square Drive Socket, reengage the puller onto the stud until the tool is flush with the flange. After the tensioner is flush, continue to turn the puller **ONE HALF TURN FURTHER** to fully reset the tool.

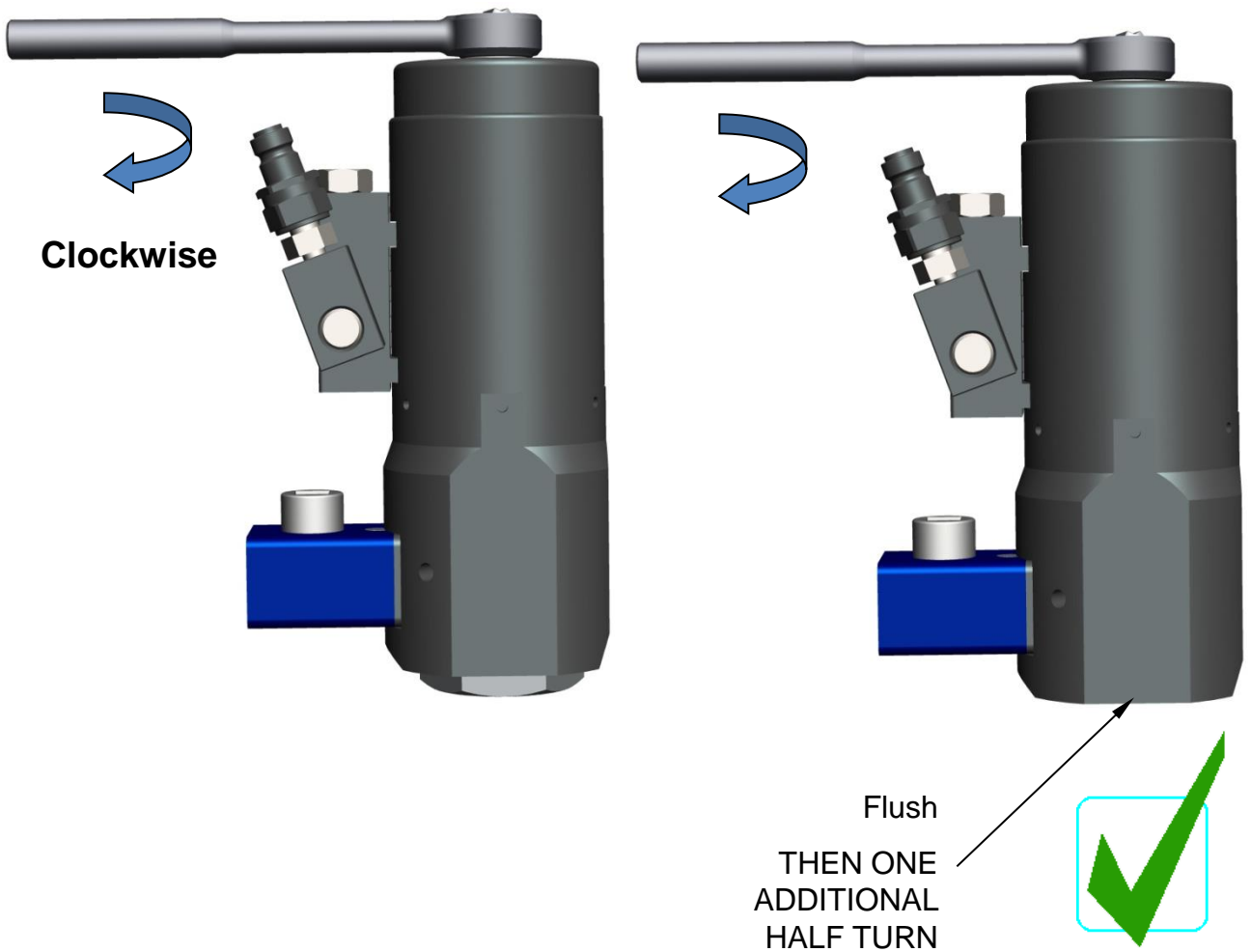

Reconnect the hydraulic hose.



## Step 11 – Tightening a Bolt



Apply the correct hydraulic pressure again, and wind the nut again once this is achieved.



DO NOT exceed the maximum stroke. This is indicated by stroke indicators around the top of the Puller

DO NOT exceed the Maximum Operating Pressure for the tool.

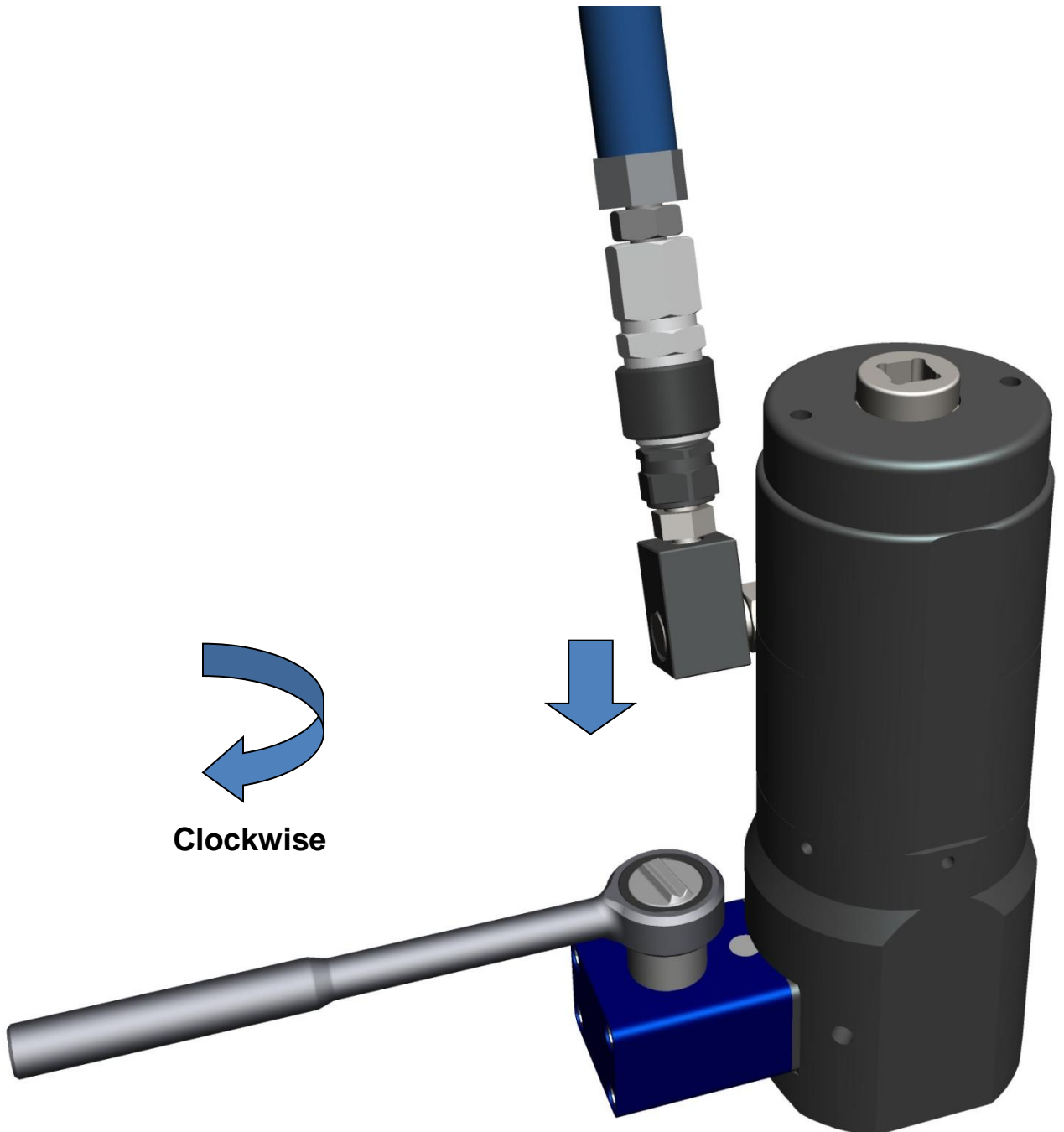

## Step 12 – Tightening a Bolt

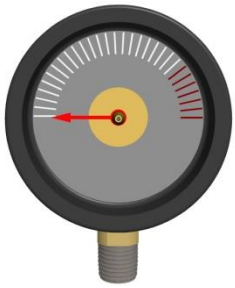

Slowly release the hydraulic pressure.

If a Low Pressure Oil Return Hose is available, attach it to accelerate retraction following the procedure outlined in Step 9. Otherwise, allow the tool to retract through the hydraulic hose and then remove once the stroke has returned to zero.

## Step 13 – Tightening a Bolt

Remove the Tensioner using the 1/2in Square Drive in the top of the Puller.

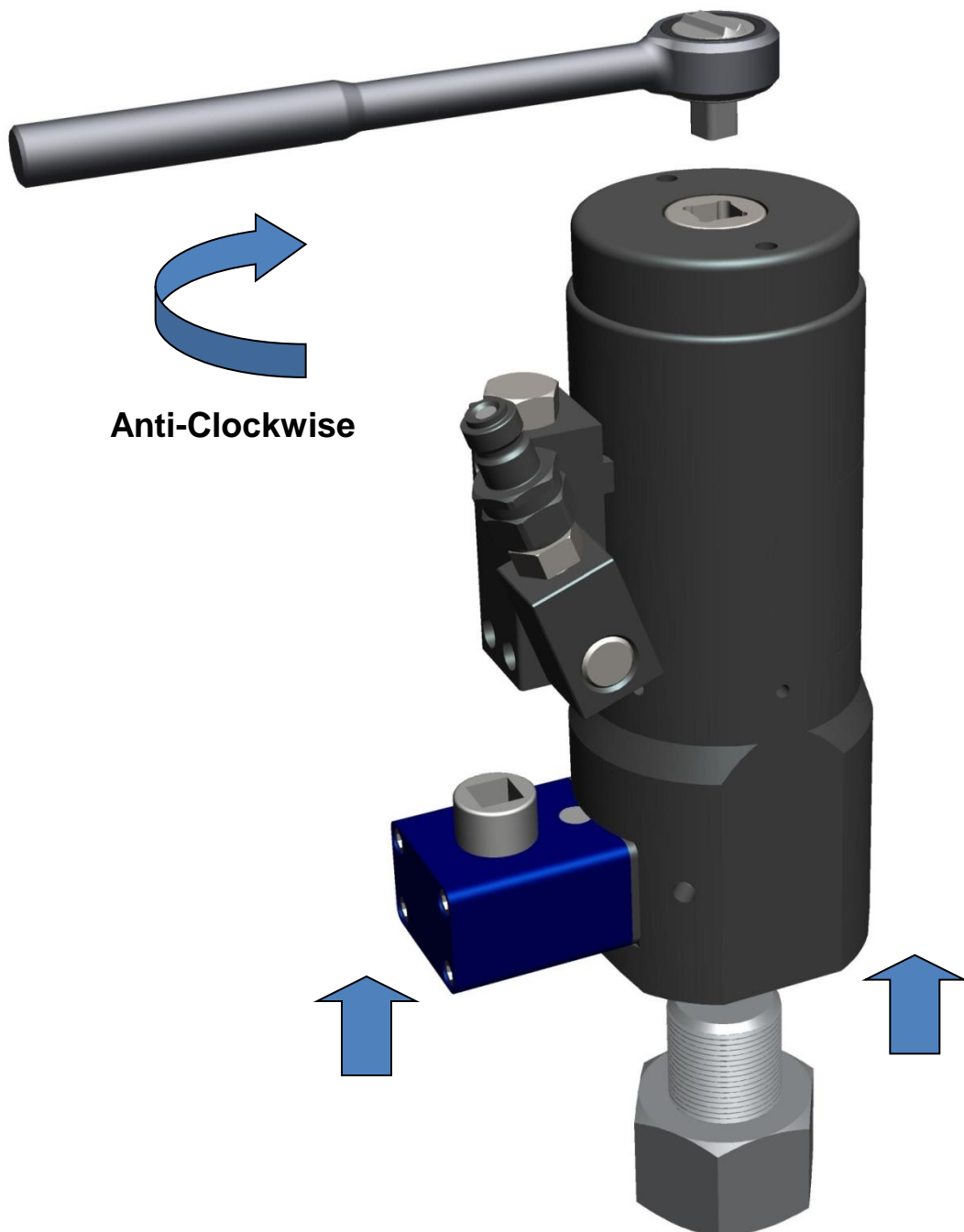

## Step 1 – Loosening a Bolt

Before commencing the bolt tensioning operation read and comply with all of the Health & Safety Instructions in Section 2. Operators should also be familiar with the 'Important Information' literature in Sections 1 and 5.

## Step 2 – Loosening a Bolt

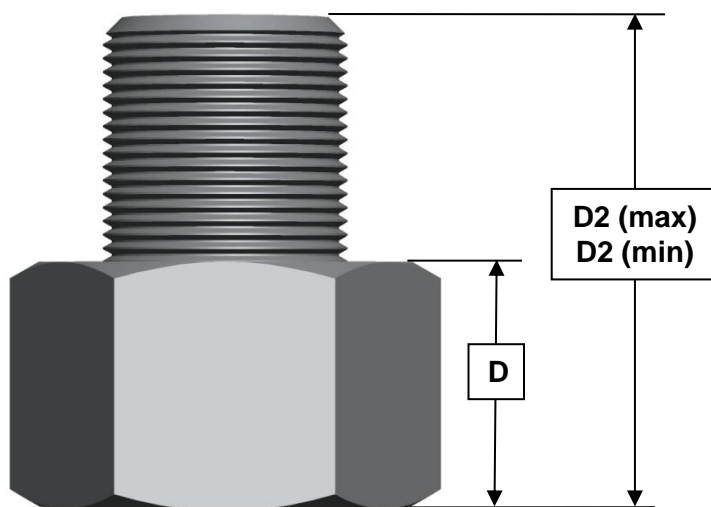

Ensure that at least D2 (min) of the bolt is protruding. The nut and washer dimensions, "D", must also be in accordance with the information in section 5.

## Step 3 – Loosening a Bolt

Position the Tensioner over the bolt to be Loosened. Orient the tensioner so that manifold is accessible, and such that the bridge allows access to the gear box.

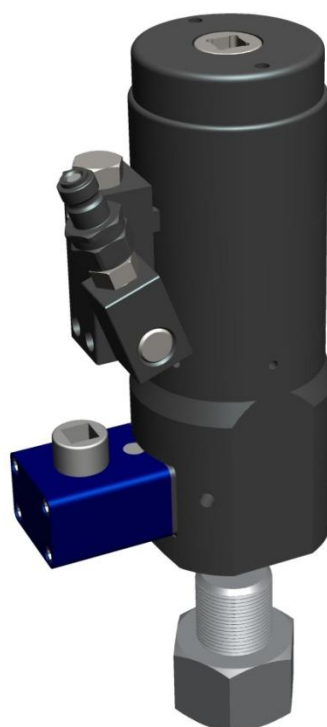

## Step 4 – Loosening a Bolt

Engage the Puller with the bolt. A 1/2in Square Socket is provided in the top of the Puller Bar so that the Tensioner orientation can be maintained whilst the Puller engages the bolt.

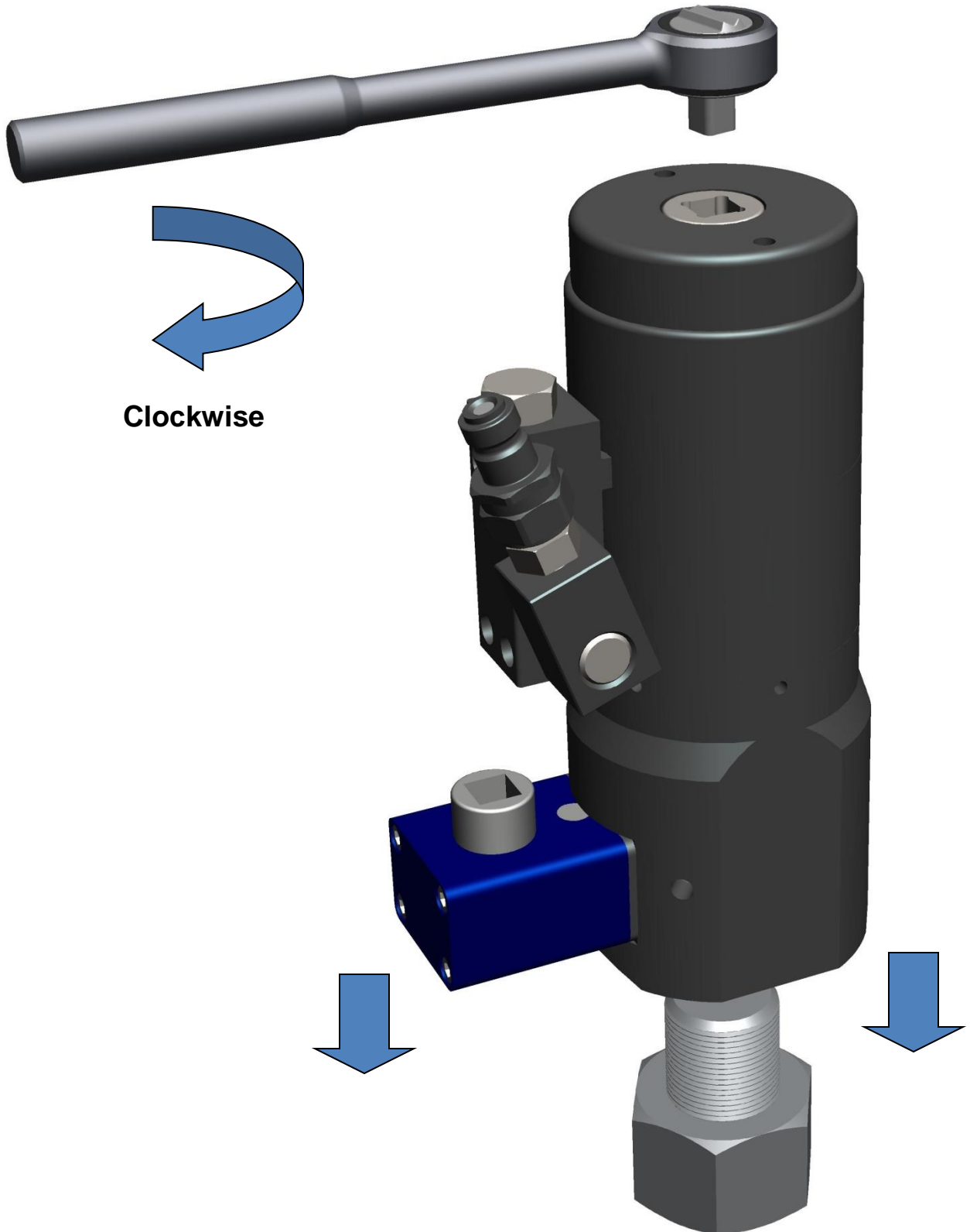

Continue rotating the Puller, increasing its engagement with the bolt until the bridge is flush with the washer. To ensure the tool is fully flush, it may be necessary to rotate the gearbox slightly whilst lowering to fully engage the gear driven socket with the nut.

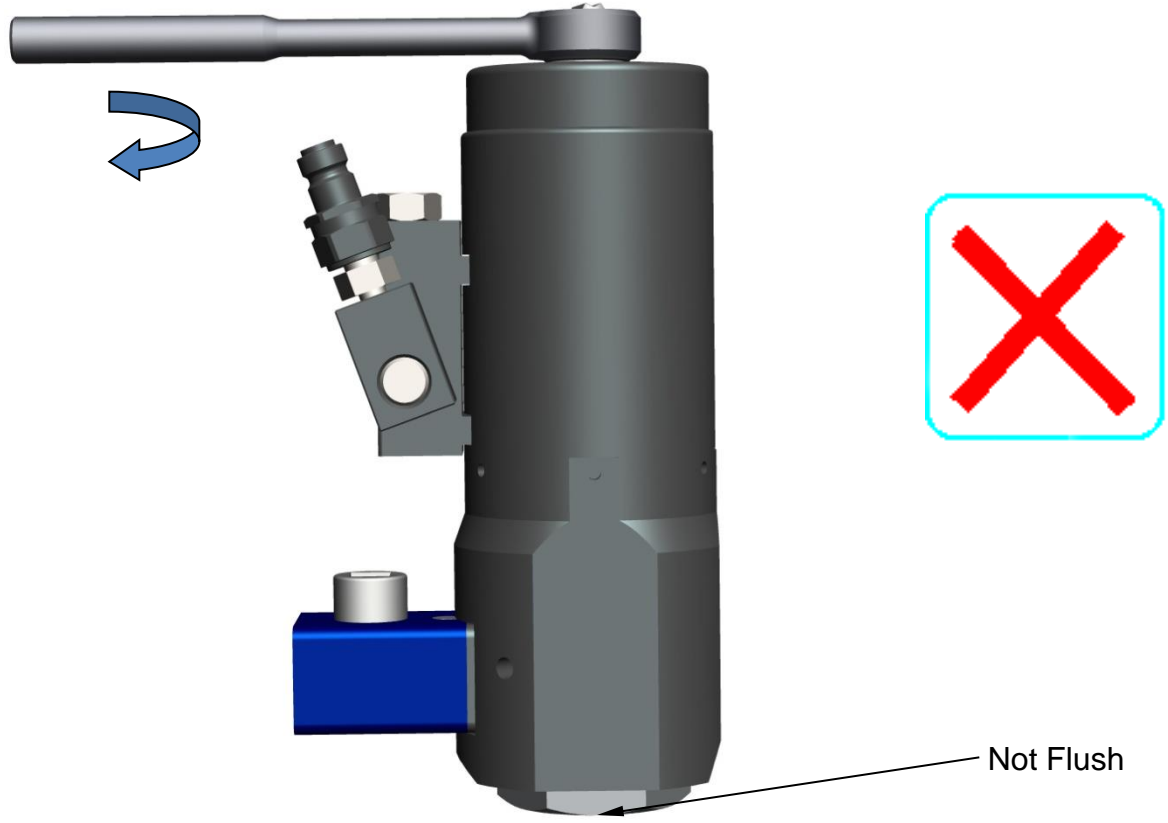
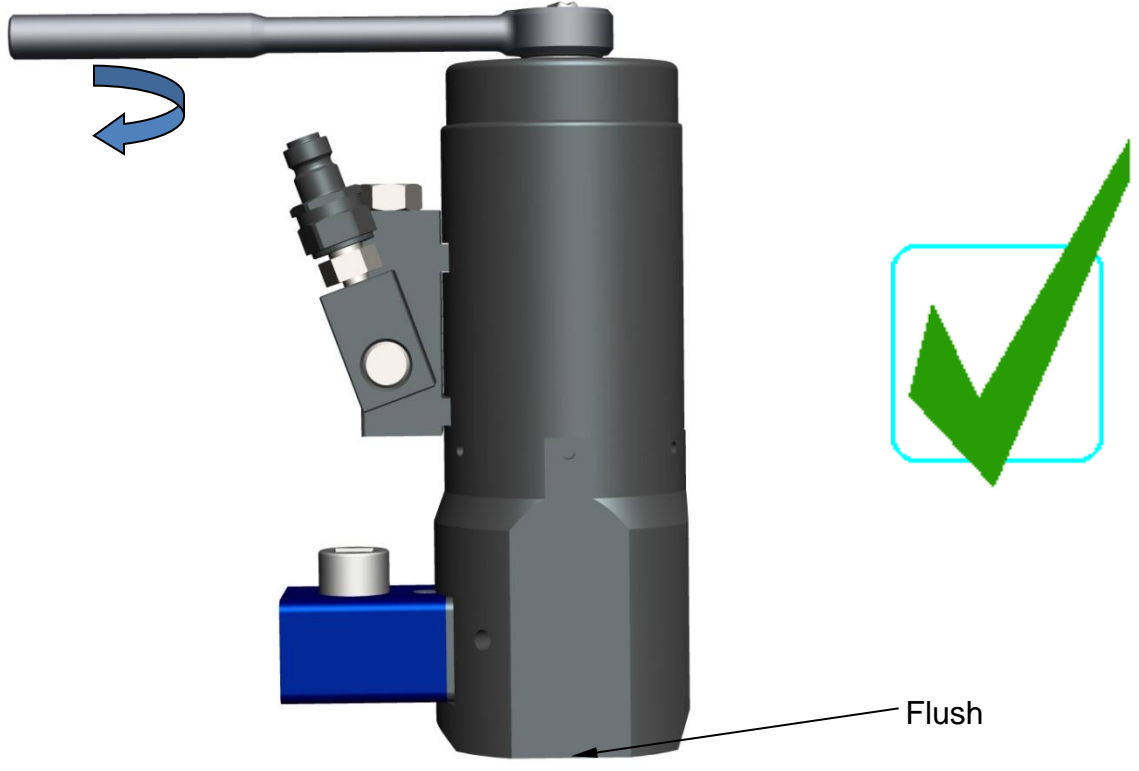

## Step 5 – Loosening a Bolt

Now rotate the Puller ANTI-CLOCKWISE BY HALF A TURN. This is to prevent the Tensioner from locking onto the stud.

### Anti Clockwise half a turn

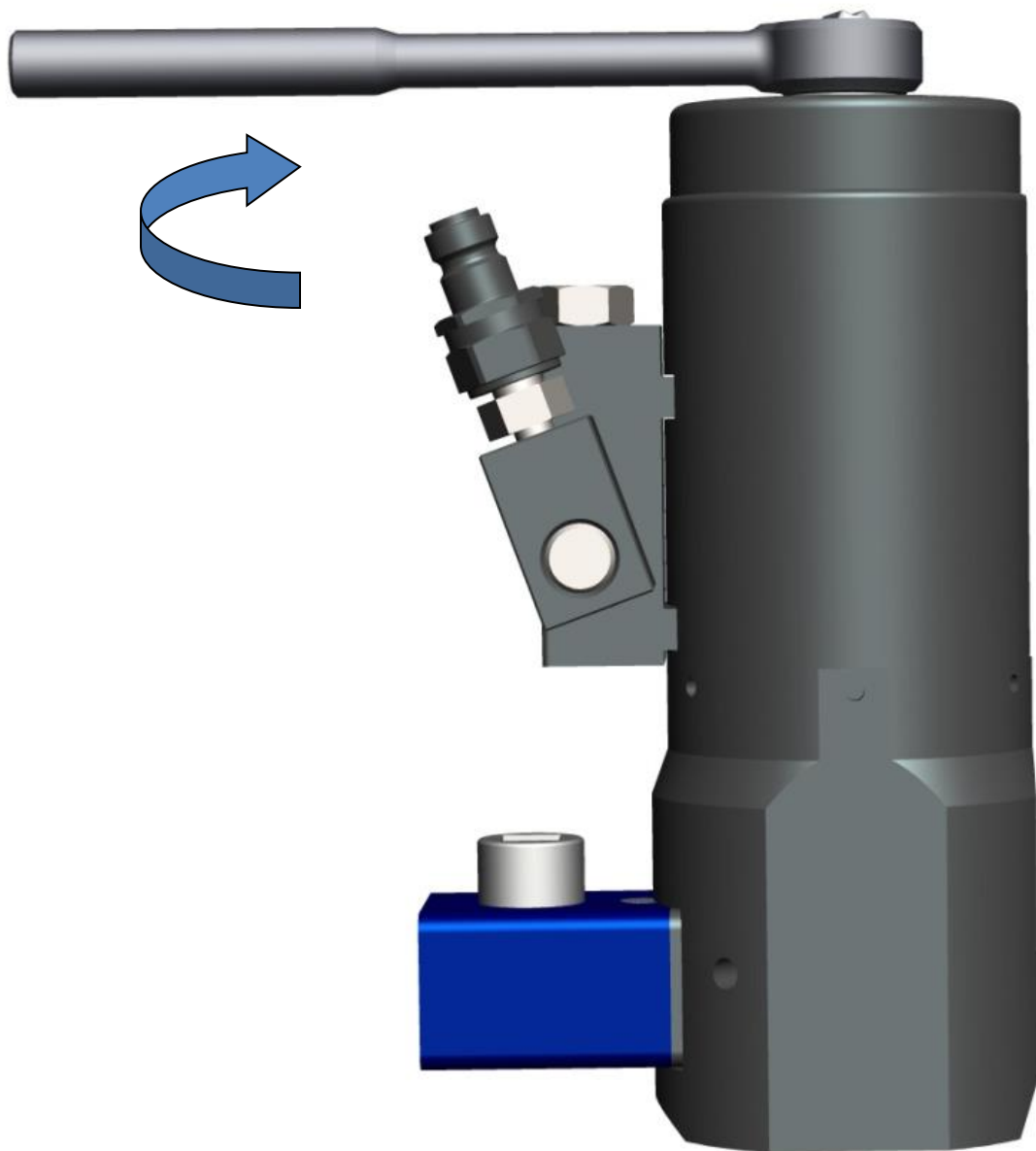

Once the Tensioner is in situ, it should still be possible to rotate the bridge to a suitable angle to access the bolt if required.

## Using Quick Connectors

Before using Quick Connectors the operator should ensure that they have read and understood the Quick Connectors Health and Safety instructions in section 1. To connect the Quick Connect Coupling and Nipple, first check there is no pressure in the system. Then pull back the shroud by hand and push the coupling onto the nipple. When together, release the shroud which will spring back to lock the Coupling and Nipple together. To disconnect, first check there is no pressure in the system. Pull back the shroud, by hand, and pull the coupling and nipple apart. Release the shroud when apart.

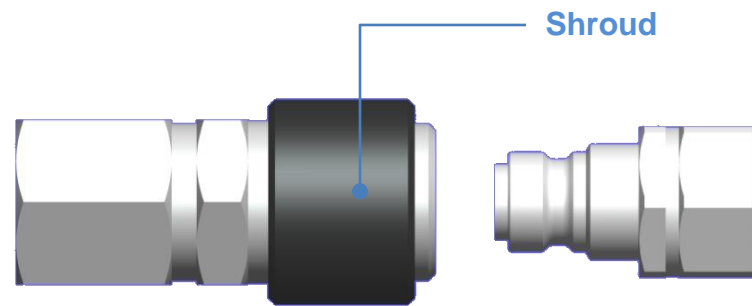

Pull the shroud back to retract.

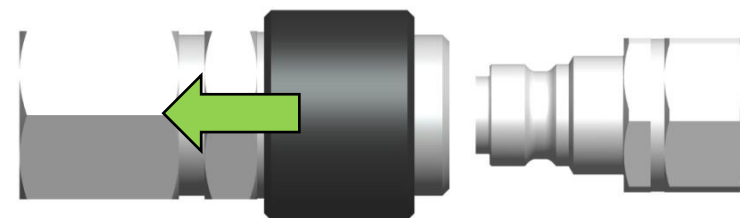

Coupling and nipple with the shroud retracted.

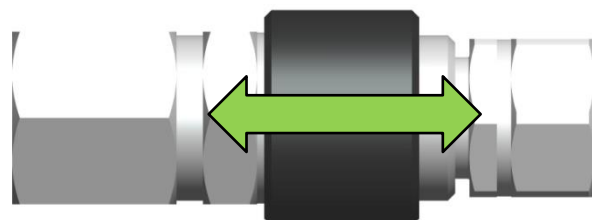

Coupling and nipple pushed together with the shroud retracted.

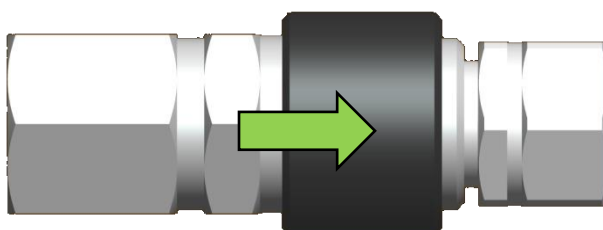

Shroud released, coupling and nipple are now locked together and safe to use.



## Step 6 – Loosening a Bolt

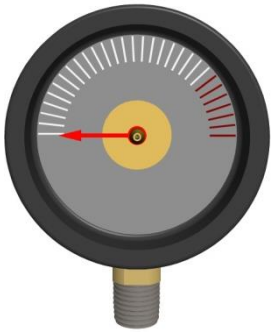

Connect a suitable high pressure hydraulic hose.

Make sure the quick connect coupling is fully engaged.

**Hydraulic  
Hose**

**Quick Connect  
Coupling**



## Health & Safety



THINK SAFETY

The Tensioner is now ready to be pressurised. Before proceeding, operators must familiarise themselves with the Health & Safety Instructions given in this manual, and proceed as follows:-

**Clear all personnel from the area where the bolt tensioning operation is to be performed. Position the pump a safe distance away from the bolt tensioners. Set up barriers and warning signs, or make other adequate arrangements to prevent unauthorised personnel from accidentally straying into the bolt tensioning area.**

**Ensure that nobody is allowed to stand near to a bolt tensioning tool during pressurisation. At no time should anyone allow any part of their body to be positioned over the bolt axis of a bolt tensioner whilst the pressure is rising or when it is pressurised. Do not allow anyone to stand anywhere in or near the axis of a bolt during the tensioning operation.**

**Do not approach a bolt tensioning tool whilst it is being pressurised. Remember that a damaged bolt or tool is most likely to fail at this critical time. When the operating pressure has been reached, approach a pressurised bolt tensioning tool only for as long as is necessary to rotate the ring nut. Ensure that when rotating the nut you are well outside of the tensioner's vertical axis.**

**PPE (Personal Protective Equipment) must be worn by all personnel using bolt tensioning tools. SAFETY GLASSES and GLOVES are essential. OVERALLS and a HARD HAT are recommended.**

**Never leave a pressurised bolt tensioning tool unattended.**

**Release the oil pressure immediately if any unauthorised person moves into the bolt tensioning area and especially if anyone stands in the axis of a bolt being tensioned.**

**Determine the correct working pressure for the bolts to be tightened.**

**Proceed with the following operations keeping the bolt tensioning tools under pressure for the minimum time necessary to complete the bolt tightening operation.**

## Step 7 – Loosening a Bolt



Apply the correct hydraulic pressure. The tool will begin to stroke and the operator should observe the top of the Puller ascending through the top of the tool.



DO NOT exceed the maximum stroke. This is indicated by stroke indicators around the top of the Puller.



DO NOT exceed the maximum operating pressure of the tool.

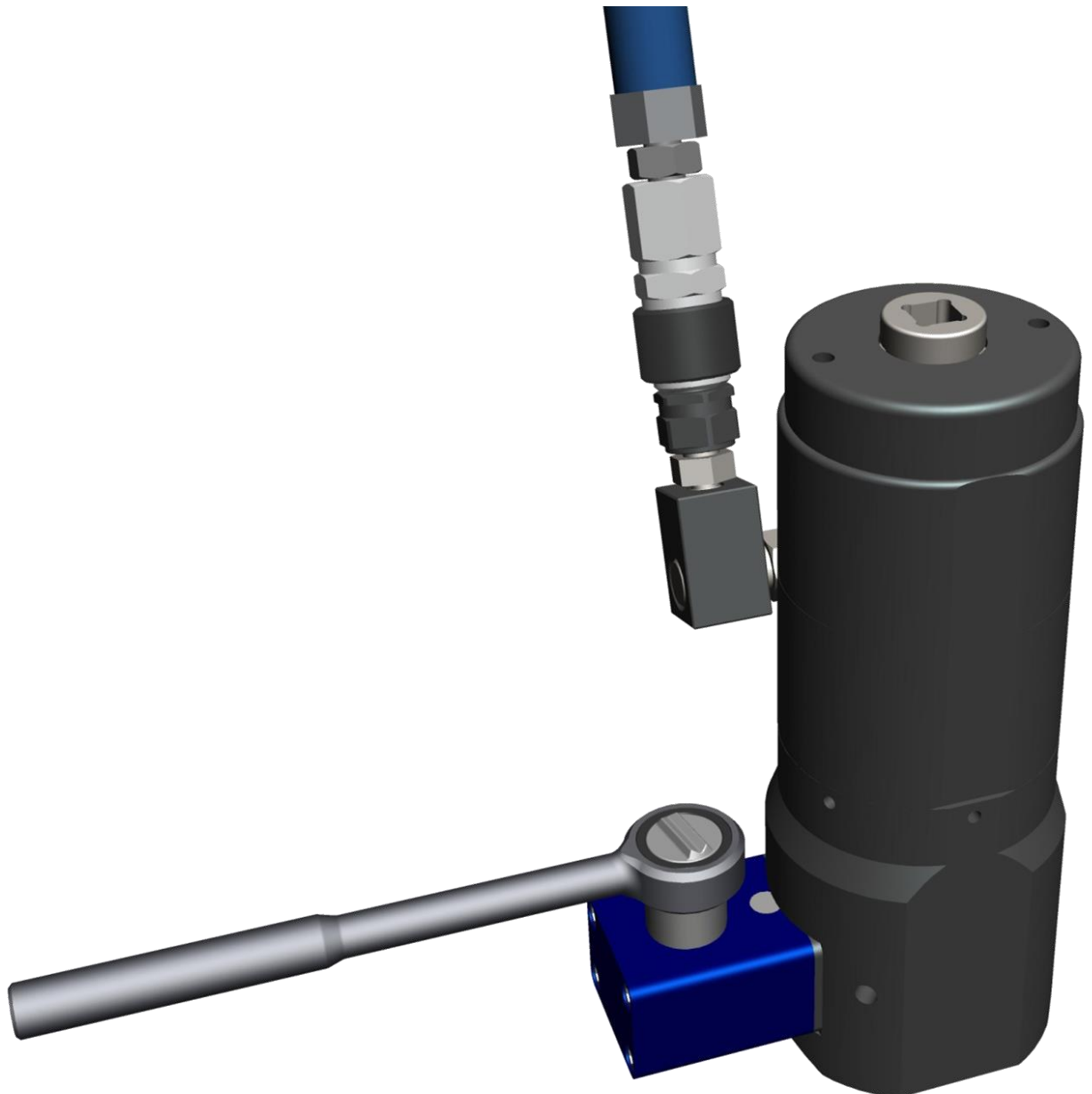

## Step 8 – Loosening a Bolt



Use a ½" Drive.

Insert the Drive into Drive Socket on the top of the Gearbox.

Rotate the Socket until the Nut is loose and clear of the flange.

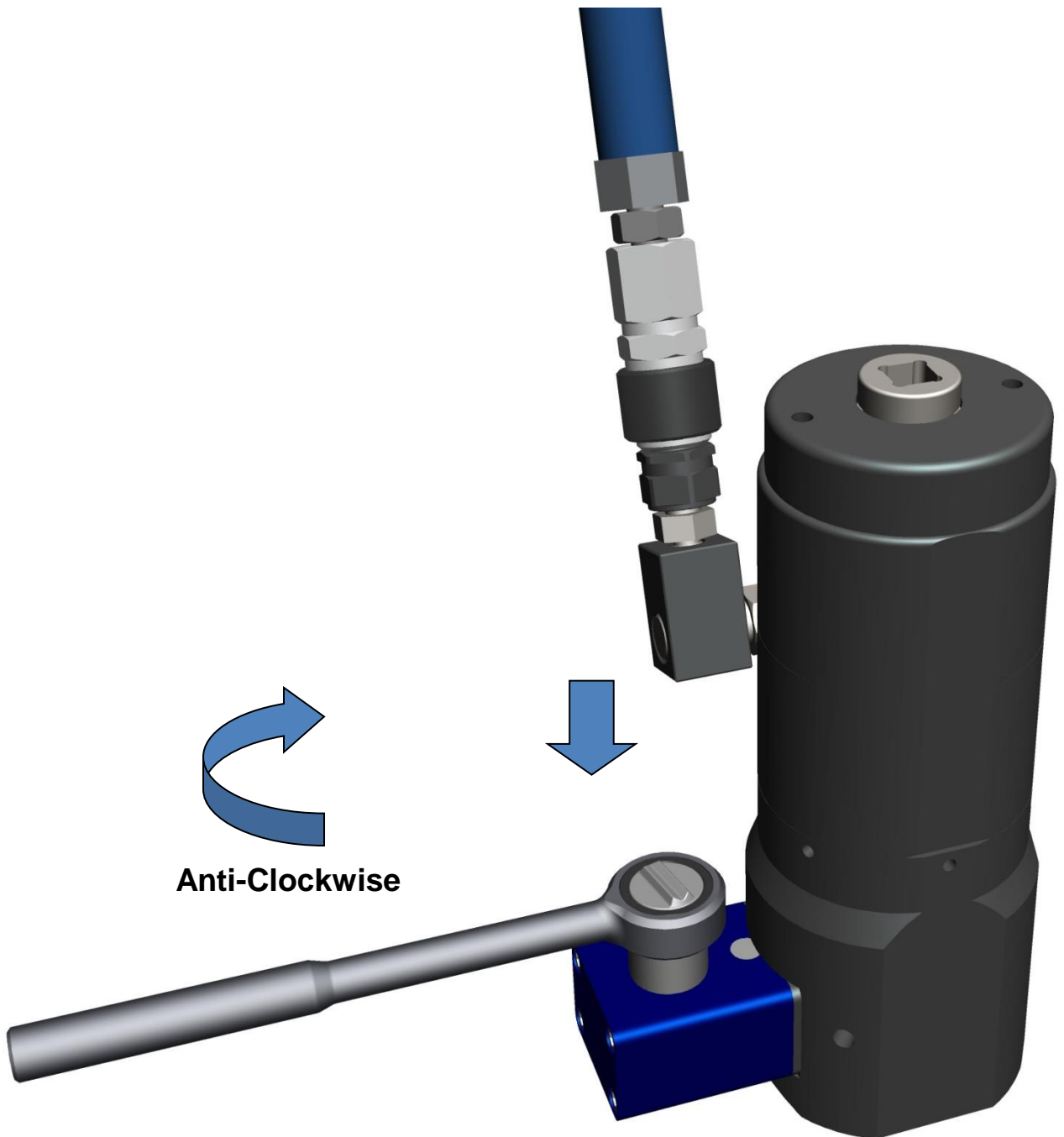

**Anti-Clockwise**

## Step 9 – Loosening a Bolt

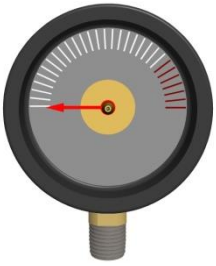

Slowly release the hydraulic pressure

## Step 10 – Loosening a Bolt



The spring retract system will now fully retract the tensioning tool.

OPTIONAL - If available, connect a Low Pressure Oil Return Hose. The hose is connected between the tool and the top of the oil reservoir on the air driven pump. This will allow the tool to retract more quickly than if the hydraulic hoses are used.

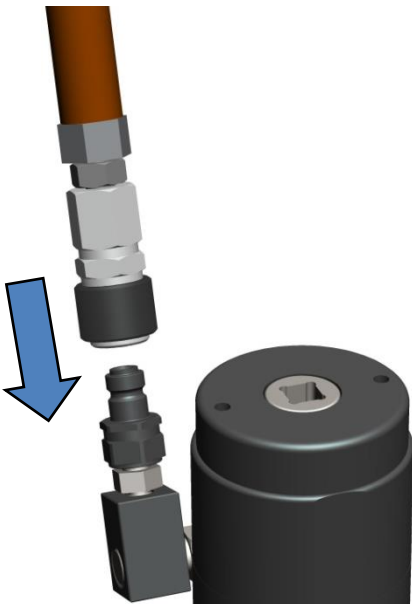
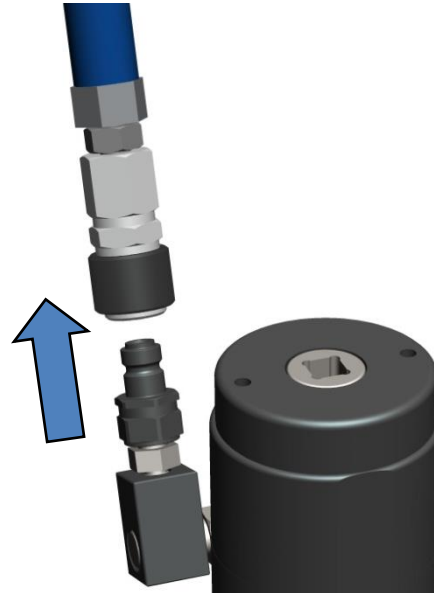

## Step 11 – Loosening a Bolt

Remove the Tensioner using the 1/2in Square Drive in the top of the Puller.

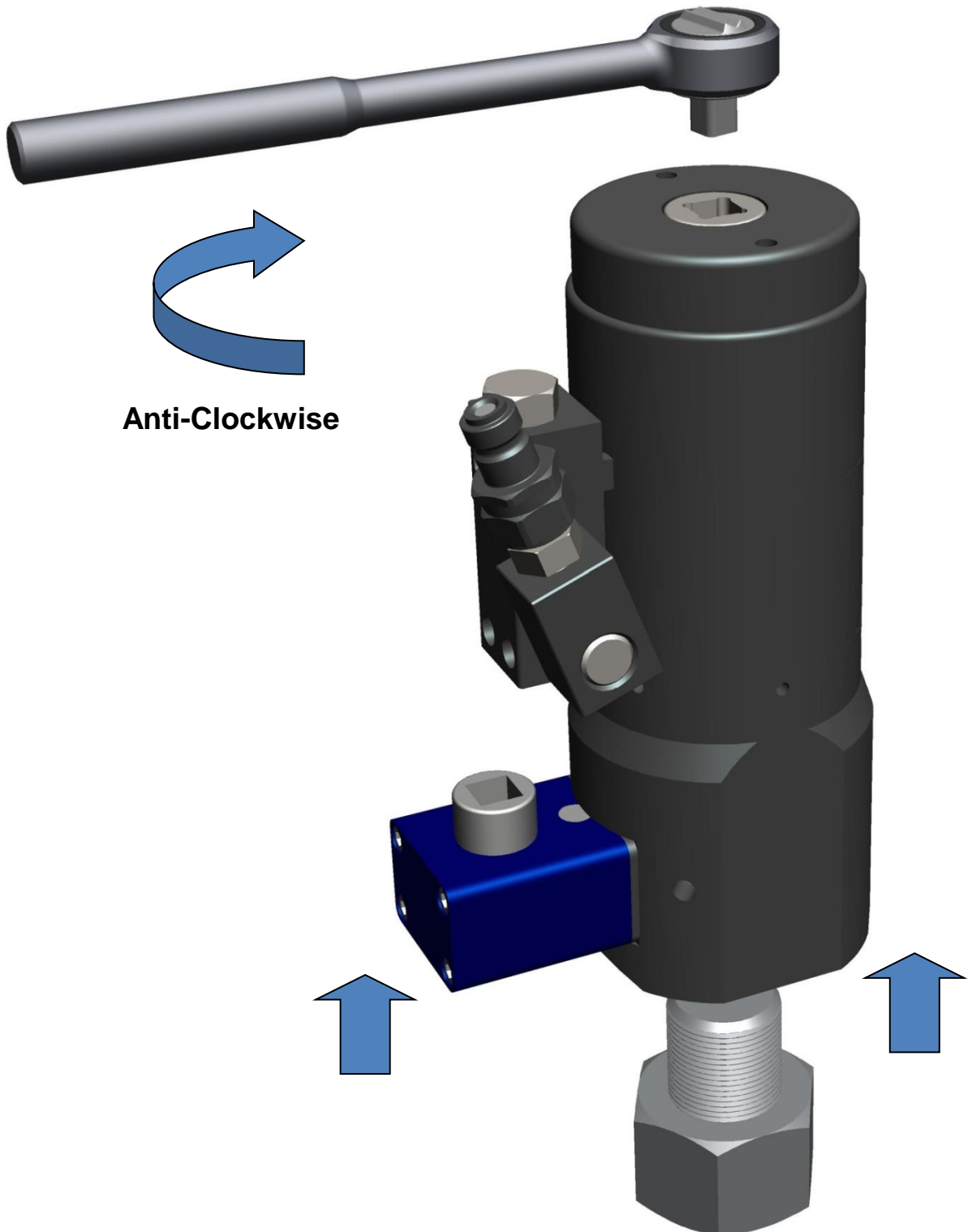

# **Section 4**

## **Maintenance & Storage**





## **General Information**

A hydraulic bolt tensioning tool will provide many years of trouble free service if used, maintained and stored correctly.

## **Storage**

Your tools were chemically blacked before leaving the factory. This provides a degree of corrosion protection but additional protection should be applied when the tools are to be stored for any period of time. It is recommended that, before storage, the tools should be checked for damage and if OK, lightly oiled.

Prior to storage, the tensioner must be retracted to zero stroke and the hydraulic connection must have its plastic protective cap fitted. The hydraulic bolt tensioner should be stored upright in a clean, dry environment. The tensioners were delivered in wooden cases and these can be used to store the tools.

## **Maintenance**

Very little maintenance is required for a bolt tensioning tool. The only items which may require changing will be the seals and the quick connect fittings. However, the seals have a very long life and are not expected to require attention during the life of the bolt tensioning tool. If the seals fail to hold pressure it may be necessary to change them, however owing to the complexity of the tensioner it is not recommended that the tools are dismantled and any maintenance performed by the customer.

Boltight recommend that tools are periodically returned for factory refurbishment. Please contact us for details.



# **Section 5**

## **Specification**



# Bolt Tensioning Tool TTM-M030-21-00 Oil Pressure vs Theoretical Tensioning Force

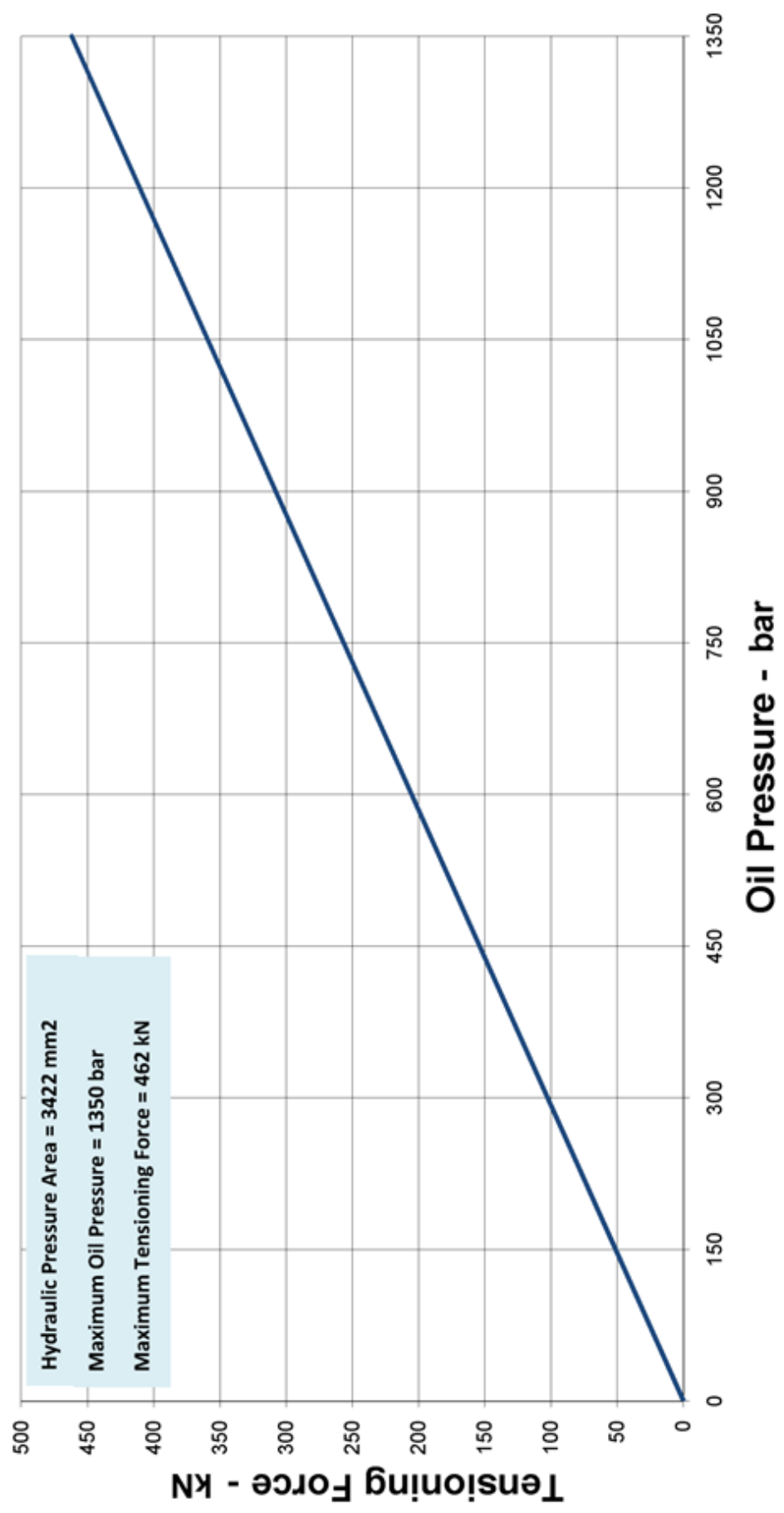

## Tool Specification

### M30 x 3.5

<b>Tool No</b>	<b>TTM-M030-21-00</b>	
<b>Thread Size</b>	<b>M30 x 3.5</b>	
<b>Tensioner Outer Diameter</b>	<b>72 mm</b>	<b>(2.83 in)</b>
<b>Bridge Outer Diameter</b>	<b>83.5 mm</b>	<b>(3.29 in)</b>
<b>Tensioner Height</b>	<b>201 mm</b>	<b>(7.91 in)</b>
<b>Hydraulic Pressure Area</b>	<b>3422 mm<sup>2</sup></b>	<b>(5.30 in<sup>2</sup>)</b>
<b>Maximum Pressure</b>	<b>1350 bar</b>	<b>(19580 psi)</b>
<b>Maximum Load @ 1350 bar</b>	<b>462.0 kN</b>	<b>(104 klbf)</b>
<b>Maximum Stroke</b>	<b>7 mm</b>	<b>(0.276 in)</b>
<b>Tensioner Weight</b>	<b>5.7 kg</b>	<b>(12.6 lb)</b>
<b>Maximum Pressure Cycles</b>	<b>6,000</b>	

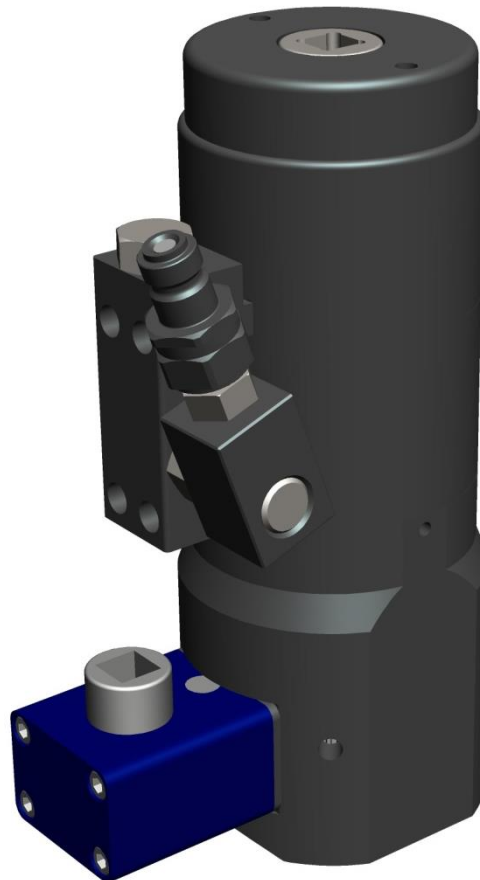

**M30 x 3.5 Multi-Stage Typhoon Tensioner**

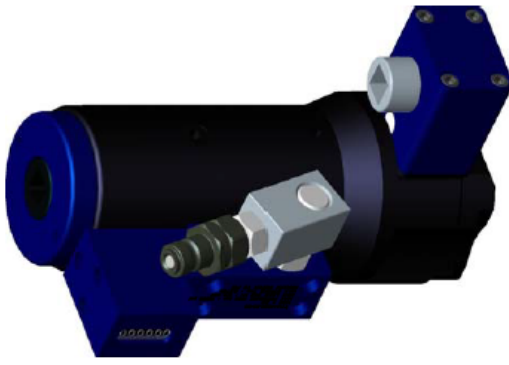

SCALE 0.500

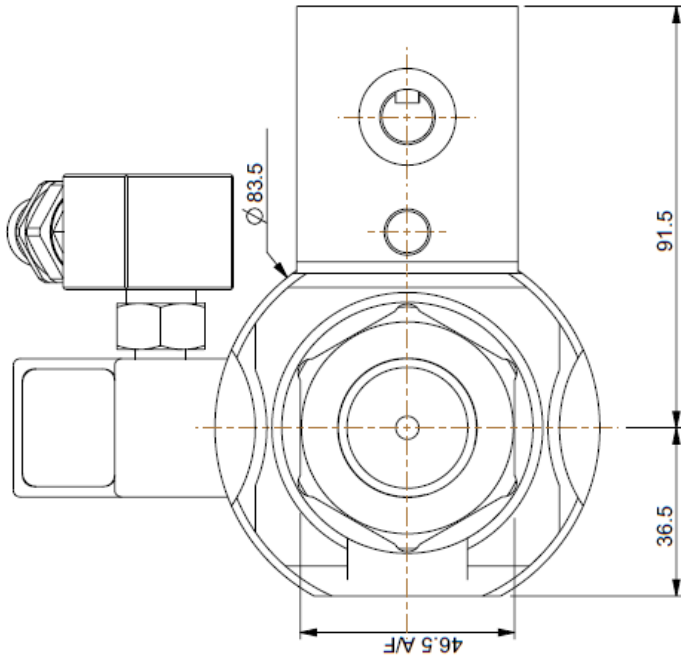

TOOL FEATURES:

- OPTIONAL CYCLE COUNTER
- FAST SPRING RETURN
- OPTIONAL CARRYING HANDLE
- HIGH CYCLE FATIGUE LIFE
- SAFE FAILURE DESIGN
- ANTI-OVERSTROKE FACILITY
- LONG LIFE SEAL PERFORMANCE
- OPTIONAL NIPPLE/COUPLING CONFIGURATIONS
- LOW MAINTENANCE SPRING LOADED GEAR DRIVE

SPECIFICATION

	1350	bar	19580	psi
MAX WORKING PRESSURE	462.0	kN	104	klbf
MAX LOAD	7	mm	0.276	in
MAX STROKE	5.7	kg	12.6	lb
APPROX. TOOL WEIGHT				

VIEW SHOWING BRIDGE PROFILE

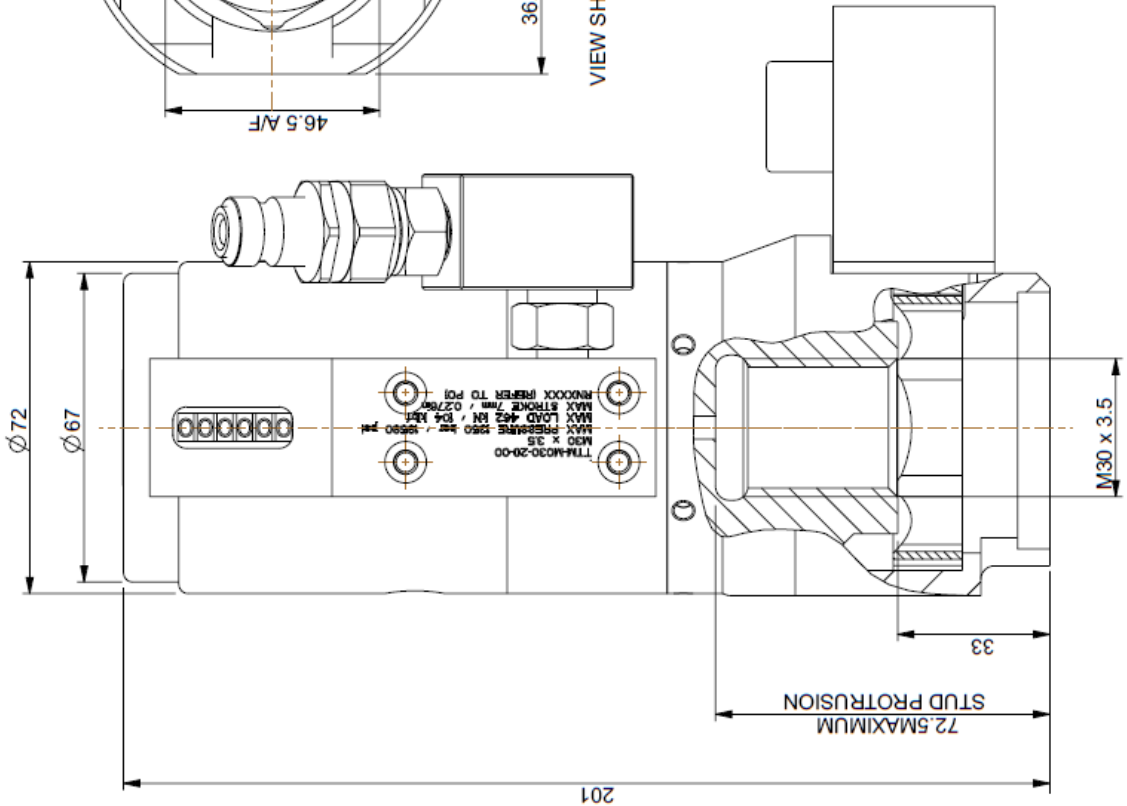

MATERIAL	FINISH	SURFACE FINISH	LIMITS U.S.O.	SIZE	SCALE	REV	CNN	DRAWN	CHECKED	DATE	DRAWING NO.	ISSUE
		1/1	±0.25 ± 0.25 *	A3	1:1000	A	-	PJ	MR	120710	TTM-M030-21-00	A
TITLE												
M30 x 3.5 MULTI STAGE TYPHOON TENSIONER												



THIS DRAWING AND THE DESIGN IS THE PROPERTY OF BOLTIGHT LTD AND MUST NOT BE COPIED OR DISCLOSED WITHOUT THE WRITTEN CONSENT OF THE COMPANY

ALL DIMS MM U.S.O.  
DO NOT SCALE

## IMPORTANT INFORMATION

1. ONLY EVER USE THE TOOL WHERE THE STUD PROTRUSION IS BETWEEN **63mm** AND **72mm**, AND WHERE THE COMBINED NUT AND WASHER HEIGHT IS NO GREATER THAN **31mm**.

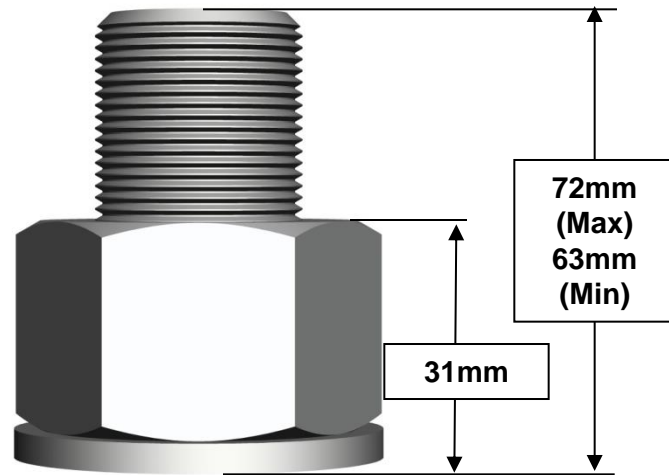

2. NEVER PRESSURISE THE TOOL BEYOND ITS MAXIMUM WORKING PRESSURE OF **1350 bar (19580 psi)**.



**$\leq$  1350 bar**

3. DO NOT EXCEED THE MAXIMUM STROKE OF **7mm**. EVEN THOUGH THE TOOL FEATURES AN ANTI-OVERSTROKE FACILITY, THE OPERATOR SHOULD NEVER INTENTIONALLY OVERSTROKE THE TOOL.





**END OF DOCUMENT**