



## Klasik Seri Havalı Tork Anahtarları

### Classic Series Pneumatic Torque Multipliers



- ±%5 Yüksek hassasiyetli torklama işlemi
- 2.000 N.m 90 - 2.000 N.m arası kapasite seçeneği
- Sıkma ve sökmeye uygun kullanım
- Çift hızlı modellerde otomatik vites geçişi
- 170 rpm'e kadar boşa dönüş hızı
- 5.3 Maksimum 5.3 Bar hava basıncı
- 11 ltr Saniyede 11 litre hava tüketimi
- 81 dB(A) Sessiz ve darbesiz çalışma özelliği

#### Tek Hızlı Havalı Tork Anahtarları

##### Single Speed Pneumatic Torque Multipliers

Model	Parça Part	Kapasite Capacity		Devir Hızı Idle Speed
		N.m	Lbf.ft	
#	No.	N.m	Lbf.ft	d/d (rpm)
PT72-500	18023	90 - 500	66 - 370	35
PT72-1000	18022	190 - 1.000	140 - 740	15
PT72-1000	18026	190 - 1.000	140 - 740	15
PT72-1500	18021	300 - 1.500	220 - 1.110	9
PT72-2000	18033	400 - 2.000	300 - 1.450	6

#### İki Hızlı Havalı Tork Anahtarları

##### Two Speed Pneumatic Torque Multipliers

Model	Parça Part	Kapasite Capacity		Devir Hızı Idle Speed
		N.m	Lbf.ft	
#	No.	N.m	Lbf.ft	d/d (rpm)
PT72-500.AUT	18023.AUT	203 - 500	150 - 370	170
PT72-1000.AUT	18022.AUT	488 - 1.000	360 - 740	75
PT72-1000.AUT	18026.AUT	488 - 1.000	360 - 740	75
PT72-1500.AUT	18021.AUT	760 - 1.500	560 - 1.110	45
PT72-2000.AUT	18033.AUT	1.000 - 2.000	750 - 1.450	30

#### Ölçülendirilmiş Harfli Çizim

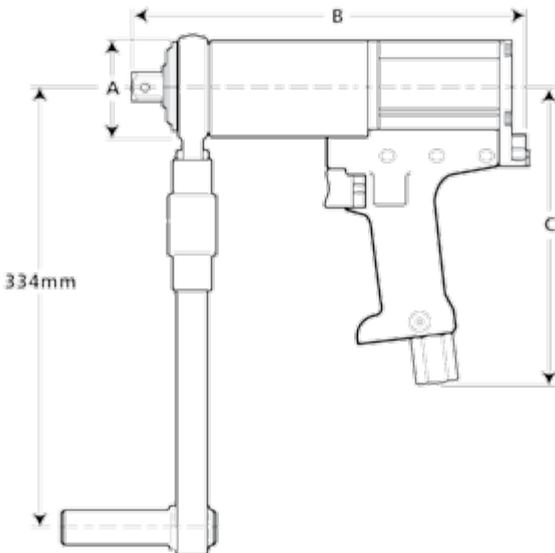

Model	Parça Part	Sürücü Sq. Drive	Ağırlık Weight	A	B	C
#	No.	inç	Kg	mm	mm	mm
PT72-500	18023	3/4"	8.1	72	301	223
PT72-1000	18022	3/4"	8.1	72	301	223
PT72-1000	18026	1"	8.1	72	301	223
PT72-1500	18021	1"	8.1	72	301	223
PT72-2000	18033	1"	8.1	72	301	223
PT72-500.AUT	18023.AUT	3/4"	10.4	72	373	223
PT72-1000.AUT	18022.AUT	3/4"	10.4	72	373	223
PT72-1000.AUT	18026.AUT	1"	10.4	72	373	223
PT72-1500.AUT	18021.AUT	1"	10.4	72	373	223
PT72-2000.AUT	18033.AUT	1"	10.4	72	373	223