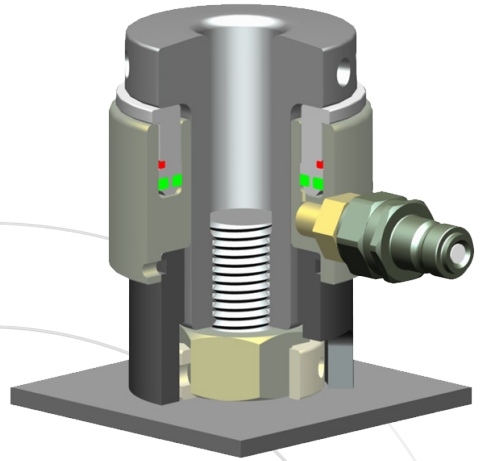
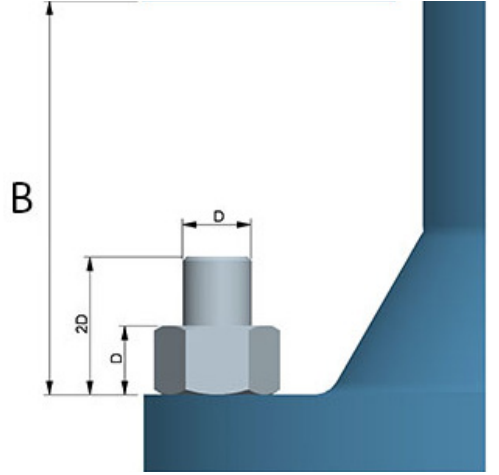

Basınç Pressure	Kuvvet Force	Tonaj Tonnage
Bar	kN	Kg/Force
50	87	8.871
100	175	17.845
150	263	26.818
200	351	35.792
250	438	44.663
300	526	53.637
350	614	62.610
400	702	71584
450	789	80455
500	877	89429
550	965	98402
600	1.053	107376
650	1.140	116.247
700	1.228	125.221
750	1.316	134.194
800	1.404	143.168
850	1.491	152.039
900	1.579	161.013
950	1.667	169.986
1.000	1.755	178.960
1.050	1.842	187.831
1.100	1.930	196.805
1.150	2.018	205.778
1.200	2.106	214.752
1.250	2.193	223.623
1.300	2.281	232.597
1.350	2.369	241.570
1.400	2.457	250.544
1.450	2.544	259.415
1.500	2.632	268.389

$$1\text{kN} = 101,971 \text{ kgf} \quad F = P \times A$$

$$\text{Etki Alanı} = 175,5 \text{ cm}^2 \quad \text{Kuvvet} = \text{Basınç} \times \text{Etki Alanı}$$

**Surkon Makina Sanayi ve Ticaret LTD. ŞTİ.**

İvedik Organize Sanayi Bölgesi - Özpetek Sanayi Sitesi  
1390 Sokak No: 12 - TR-06378 - Yenimahalle / ANKARA  
Tel: +90 (312) 386 14 64 / Faks: +90 (312) 386 14 88  
info@surkon.com / www.surkon.com



ISO 9001 : 2008  
Quality Management System  
TS EN ISO /IEC 17021  
AB - 0049 - YS  
Certificate No: 57812