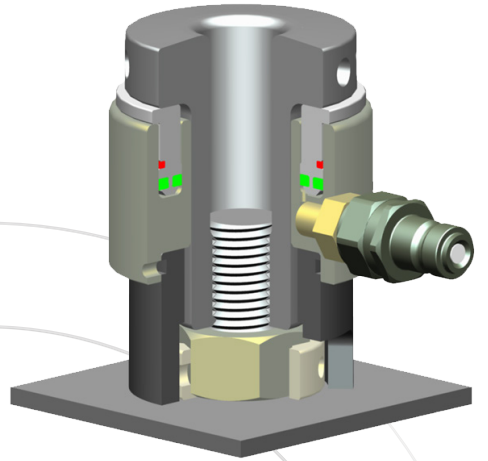
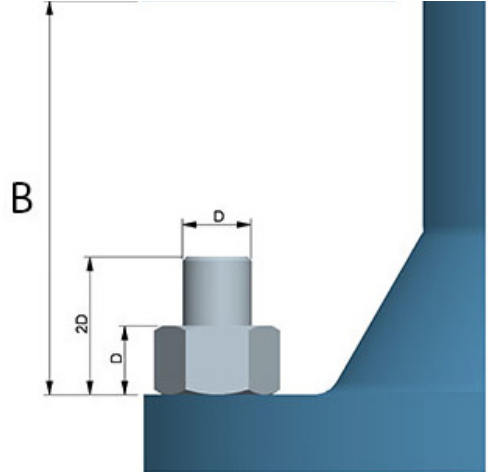

Basınç Pressure	Kuvvet Force	Tonaj Tonnage
Bar	kN	Kg/Force
50	83	8.463
100	167	17.029
150	250	25.492
200	334	34.058
250	417	42.522
300	501	51.087
350	584	59.551
400	668	68.117
450	751	76.580
500	835	85.146
550	918	93.609
600	1.002	102.175
650	1.085	110.639
700	1.169	119.204
750	1.252	127.668
800	1.336	136.234
850	1.419	144.697
900	1.503	153.263
950	1.586	161.726
1000	1.670	170.292
1050	1.753	178.756
1100	1.837	187.321
1150	1.920	195.785
1200	2.004	204.351
1250	2.087	212.814
1300	2.171	221.380
1350	2.254	229.844
1400	2.338	238.409
1450	2.421	246.873
1500	2.505	255.438

1kN = 101,971 kgf $F = P \times A$

Etki Alanı = 167 cm² Kuvvet= Basınç x Etki Alanı

**Surkon Makina Sanayi ve Ticaret LTD. ŞTİ.**

İvedik Organize Sanayi Bölgesi - Özpetek Sanayi Sitesi
1390 Sokak No: 12 - TR-06378 - Yenimahalle / ANKARA
Tel: +90 (312) 386 14 64 / Faks: +90 (312) 386 14 88
info@surkon.com / www.surkon.com



ISO 9001 : 2008
Quality Management System
TS EN ISO /IEC 17021
AB - 0049 - YS
Certificate No: 57812