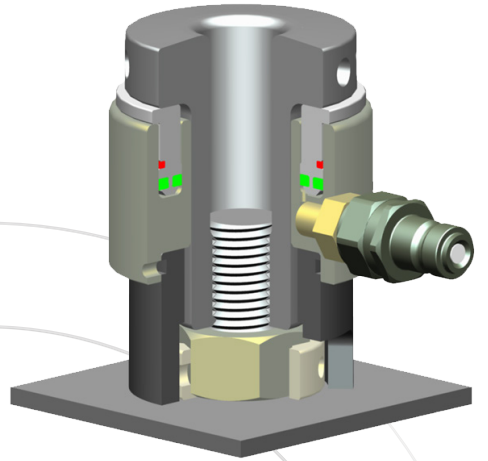
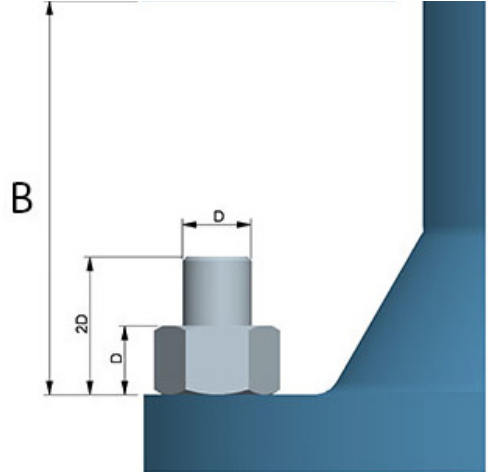

Basınç Pressure	Kuvvet Force	Tonaj Tonnage
Bar	kN	Kg/Force
50	61	6.220
100	122	10.197
150	183	18.660
200	244	24.880
250	305	31.100
300	366	37.321
350	427	43.541
400	488	49.761
450	549	55.981
500	610	62.201
550	671	68.422
600	732	74.642
650	793	80.862
700	854	87.082
750	915	93.302
800	976	99.522
850	1.037	105.743
900	1.098	111.963
950	1.159	118.183
1.000	1.220	124.403
1.050	1.281	130.623
1.100	1.342	136.844
1.150	1.403	143.064
1.200	1.464	149.284
1.250	1.525	155.504
1.300	1.586	161.724
1.350	1.647	167.944
1.400	1.708	174.165
1.450	1.769	180.385
1.500	1.830	186.605

1kN = 101,971 kgf     $F = P \times A$

Etki Alanı = 122 cm<sup>2</sup>    Kuvvet= Basınç x Etki Alanı

**Surkon Makina Sanayi ve Ticaret LTD. ŞTİ.**

İvedik Organize Sanayi Bölgesi - Özpetek Sanayi Sitesi  
1390 Sokak No: 12 - TR-06378 - Yenimahalle / ANKARA  
Tel: +90 (312) 386 14 64 / Faks: +90 (312) 386 14 88  
info@surkon.com / www.surkon.com



ISO 9001 : 2008  
Quality Management System  
TS EN ISO /IEC 17021  
AB - 0049 - YS  
Certificate No: 57812