

Basınç <i>Pressure</i>	Kuvvet <i>Force</i>	Tonaj <i>Tonnage</i>
Bar	kN	Kg/Force
50	42	4.305
100	85	8.611
150	127	12.916
200	169	17.221
250	211	21.526
300	254	25.832
350	296	30.137
400	338	34.442
450	380	38.747
500	423	43.053
550	465	47.358
600	507	51.663
650	549	55.969
700	592	60.274
750	634	64.579
800	676	68.884
850	718	73.190
900	761	77.495
950	803	81.800
1.000	845	86.106
1.050	887	90.411
1.100	930	94.716
1.150	972	99.021
1.200	1.014	103.327
1.250	1.056	107.632
1.300	1.099	111.937
1.350	1.141	116.242
1.400	1.183	120.548
1.450	1.225	124.853
1.500	1.267	129.158

1kN = 101,971 kgf

F = P x A

Etki Alanı = 84,50 cm²

Kuvvet= Basınç x Etki Alanı

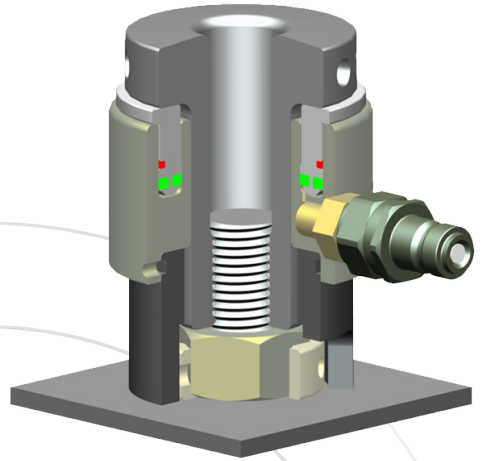
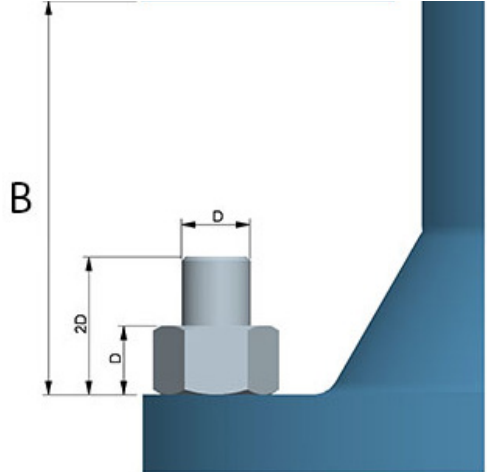

Surkon Makina Sanayi ve Ticaret LTD. ŞTİ.

İvedik Organize Sanayi Bölgesi - Özpetek Sanayi Sitesi
1390 Sokak No: 12 - TR-06378 - Yenimahalle / ANKARA
Tel: +90 (312) 386 14 64 / Faks: +90 (312) 386 14 88
info@surkon.com / www.surkon.com



ISO 9001 : 2008
Quality Management System
TS EN ISO /IEC 17021
AB - 0049 - YS
Certificate No: 57812