

| Basınç<br><i>Pressure</i> | Kuvvet<br><i>Force</i> | Tonaj<br><i>Tonnage</i> |
|---------------------------|------------------------|-------------------------|
| Bar                       | kN                     | Kg/Force                |
| 50                        | 26                     | 2.636                   |
| 100                       | 52                     | 5.271                   |
| 150                       | 79                     | 7.907                   |
| 200                       | 105                    | 10.542                  |
| 250                       | 131                    | 13.178                  |
| 300                       | 158                    | 15.813                  |
| 350                       | 184                    | 18.449                  |
| 400                       | 211                    | 21.084                  |
| 450                       | 237                    | 23.720                  |
| 500                       | 263                    | 26.355                  |
| 550                       | 290                    | 28.991                  |
| 600                       | 316                    | 31.626                  |
| 650                       | 343                    | 34.262                  |
| 700                       | 369                    | 36.897                  |
| 750                       | 395                    | 39.533                  |
| 800                       | 422                    | 42.168                  |
| 850                       | 448                    | 44.804                  |
| 900                       | 474                    | 47.439                  |
| 950                       | 501                    | 50.075                  |
| 1.000                     | 527                    | 52.710                  |
| 1.050                     | 554                    | 55.346                  |
| 1.100                     | 580                    | 57.981                  |
| 1.150                     | 606                    | 60.617                  |
| 1.200                     | 633                    | 63.252                  |
| 1.250                     | 659                    | 65.888                  |
| 1.300                     | 685                    | 68.523                  |
| 1.350                     | 712                    | 71.159                  |
| 1.400                     | 738                    | 73.794                  |
| 1.450                     | 765                    | 76.430                  |
| 1.500                     | 791                    | 79.065                  |

1kN = 101,971 kgf

F = P x A

Etki Alanı = 52,71 cm<sup>2</sup>

Kuvvet= Basınç x Etki Alanı

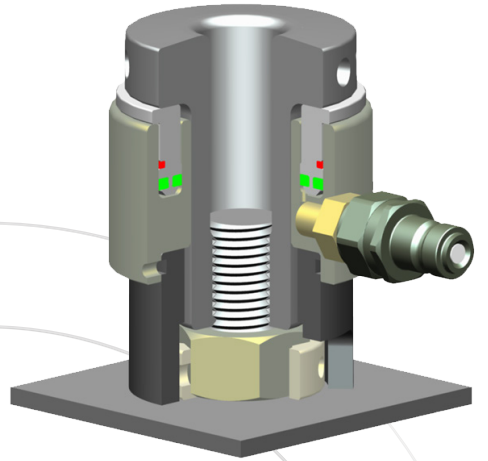
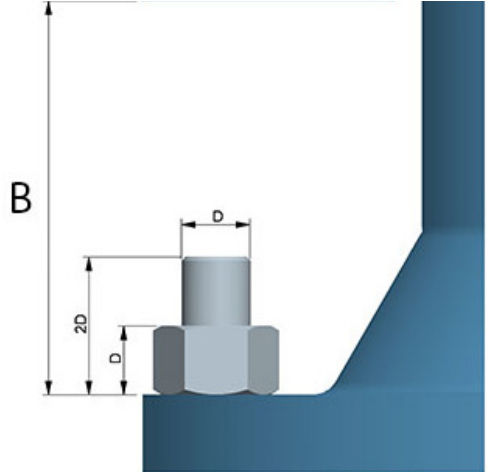
**Surkon Makina Sanayi ve Ticaret LTD. ŞTİ.**

İvedik Organize Sanayi Bölgesi - Özpetek Sanayi Sitesi  
1390 Sokak No: 12 - TR-06378 - Yenimahalle / ANKARA  
Tel: +90 (312) 386 14 64 / Faks: +90 (312) 386 14 88  
info@surkon.com / www.surkon.com



ISO 9001 : 2008  
Quality Management System  
TS EN ISO /IEC 17021  
AB - 0049 - YS  
Certificate No: 57812