

Basınç <i>Pressure</i>	Kuvvet <i>Force</i>	Tonaj <i>Tonnage</i>
Bar	kN	Kg/Force
50	14	1.427
100	28	2.855
150	43	4.384
200	57	5.812
250	72	7.341
300	86	8.769
350	100	10197
400	115	11.726
450	129	13.154
500	144	14.683
550	158	16.111
600	172	17.539
650	187	19.068
700	201	20.496
750	216	22.025
800	230	23.453
850	244	24.881
900	259	26.410
950	273	27.838
1.000	288	29.367
1.050	302	30.795
1.100	316	32.223
1.150	331	33.752
1.200	345	35.180
1.250	360	36.709
1.300	374	38.137
1.350	388	39.564
1.400	403	41.094
1.450	417	42.522
1.500	432	44.051

1kN = 101,971 kgf

F = P x A

Etki Alanı = 28,8 cm²

Kuvvet= Basınç x Etki Alanı

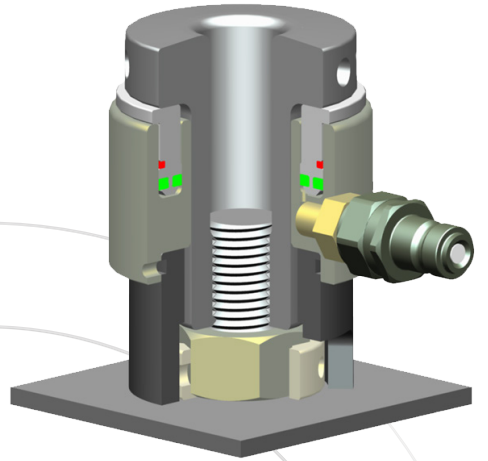
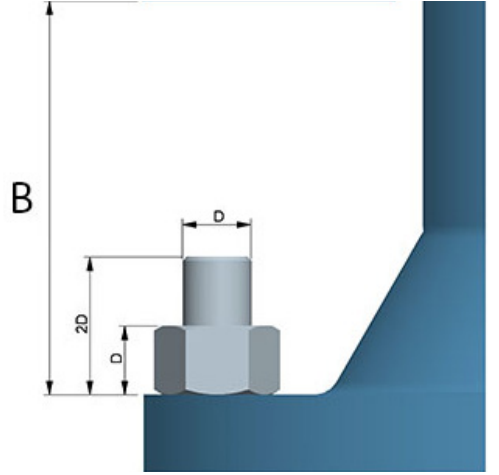
**Surkon Makina Sanayi ve Ticaret LTD. ŞTİ.**

İvedik Organize Sanayi Bölgesi - Özpetek Sanayi Sitesi
1390 Sokak No: 12 - TR-06378 - Yenimahalle / ANKARA
Tel: +90 (312) 386 14 64 / Faks: +90 (312) 386 14 88
info@surkon.com / www.surkon.com



ISO 9001 : 2008
Quality Management System
TS EN ISO /IEC 17021
AB - 0049 - YS
Certificate No: 57812