

# MG7™

---

## MINI GAP FLANGE SPREADER



EQUALIZER INTERNATIONAL LTD

[www.equalizerinternational.com](http://www.equalizerinternational.com)



## INDEX

SECTION	CONTENTS	PAGE NO.
1	INTRODUCTION	1
2	TOOL SAFETY	2-3
	2.1 GENERAL SAFETY	2
	2.2 PERSONNEL COMPETENCY	2
	2.3 DISCLAIMER	2
	2.4 DEFINITION OF TERMS	3
	2.5 HAZARDS	3
3	TECHNICAL DATA	4
4	HOW THE FLANGE SPREADING WEDGES WORK	4
5	EXAMINATION, MAINTENANCE AND STORAGE	5
6	MG7TM MINI-GAP FLANGE SPREADER	5-12
	6.1 KIT COMPONENTS	5
	6.2 INSTALLATION AND OPERATION	6-8
	6.3 MAINTENANCE AND LUBRICATION	9-11
	6.3 PARTS LIST	12
	6.4 WEIGHTS AND DIMENSIONS	13
7	RANGE OF APPLICATION CHARTS	14-19

## 1. INTRODUCTION

The Equalizer MG7TM MINI-GAP FLANGE SPREADER is designed to aid the safe separation of flange faces. This system has a unique ability to break flange joints with a 2mm gap between the flange faces. The tool is designed to separate flanges while applying an immense amount of force to the correct point of separation.

To extend the service life of the tool and to ensure the tool is used safely, operators must read this instruction manual carefully before using the equipment. Following these instructions will ensure maintenance and/or installation procedures are carried out in a reliable and safe manner.

The Equalizer MG7TM Mini-Gap Flange Spreader:

- Offers a safe and reliable working method
- Provides 6.8 tonnes of spreading force
- Separates flange faces with a gap of 2mm or greater
- Is lightweight and easy to use

## 2. TOOL SAFETY

### 2.1 GENERAL SAFETY

These instructions cover the safe operation and maintenance of THE EQUALIZER **MG7™** MINI GAP FLANGE SPREADING tools. The use of these tools should be as part of a broader task-based risk assessment, which should be carried out by the operation supervisor or other competent person.

Failure to comply with the safety information contained within this manual could result in personal injury or equipment damage. Read all instructions, warnings and cautions carefully, and follow all safety precautions.

The safety of the operator, any assisting personnel and the general public is of paramount importance. Always work in accordance with applicable national, local, site & company-wide safety procedures.

### 2.2 PERSONNEL COMPETENCY

Only personnel deemed competent in the use of mechanical and hydraulic equipment should use these tools.

### 2.3 DISCLAIMER

Equalizer cannot be held responsible for injury or damage resulting from unsafe product use, lack of maintenance or incorrect product and/or system operation. If in doubt as to the safety precautions and applications, contact Equalizer using the contact details at the back of this manual.

## 2.4 DEFINITION OF TERMS

A CAUTION is used to indicate correct operating or maintenance procedures and practices to prevent damage to, or destruction of equipment or other property.

A WARNING indicates a potential danger that requires correct procedures or practices to avoid personal injury.

A DANGER is only used when your action or lack of action may cause serious injury or even death.



DO: an illustration showing how the tool should be used.



DON'T: an illustration showing an incorrect way to use a tool.

## 2.5 HAZARDS



WARNING: ensure all hydraulic components are rated to a safe working pressure of 700bar (10,000psi).



WARNING: Do not overload equipment. The risk of hydraulic overloading can be minimised by using the Equalizer Hand Pump, which has a factory-set safety valve preventing the safe working pressure being exceeded.

If alternative hydraulic pumps are used, ensure that there are adequate systems to limit the the working pressure to 700 bar (10,000 psi).



CAUTION: ensure components are protected from external sources of damage, such as excessive heat, flame, moving machine parts, sharp edges and corrosive chemicals.



CAUTION: Take care to avoid sharp bends and kinks in hydraulic hoses. Bends and kinks can cause severe back-up pressure and cause hose failure. Protect hoses from dropped objects; a sharp impact may cause internal damage to hose wire strands. Protect hoses from crush risks, such as heavy objects or vehicles; crush damage can cause hose failure.



WARNING: Applying pressure to a damaged hose may cause it to rupture.



WARNING: Immediately replace worn or damaged parts. Use only genuine Equalizer parts from approved distributors or service centres. Equalizer parts have been engineered and manufactured to be fit-for-purpose.



DANGER: To minimise risk of personal injury keep hands and feet away from the tool and workpiece during operation.



WARNING: Always wear suitable clothing and Personal Protective Equipment (PPE). Do not handle pressurised hoses; escaping oil under pressure can penetrate the skin, causing serious injury. Seek medical attention immediately if oil penetration is suspected.



WARNING: Only pressurize complete and fully connected hydraulic systems. Do not pressurize systems that contain unconnected couplers.



CAUTION: Do not lift hydraulic equipment by the hoses or couplers. Use only the designated carrying handles.



CAUTION: Lubricate tools as directed in this manual prior to operation. Use only approved lubricants of high quality, following the lubricant manufacturers instructions.



CAUTION: Only use the designated anchor point for fixing the lanyard. Do not attach the lanyard to the plastic handle.



DANGER: Care should be taken when using the lanyard to avoid entanglement with body parts.

### 3. TECHNICAL DATA

	Spreading Force
<b>MG7TMSTD</b>	6.8 T (68 kN) per tool It is recommended that tools are used in pairs giving $2 \times 6.8 = 13.6 \text{ T (136 kN)}$

The tool achieves a spreading distance of 27mm from a 2mm gap. At a 7mm gap the tool steps down the spreading force applied from 6.8 tonnes to 3.9 tonnes.

### 4. HOW THE FLANGE SPREADING WEDGES WORK



**2) Tool assembly**

**1) Select tool configuration**

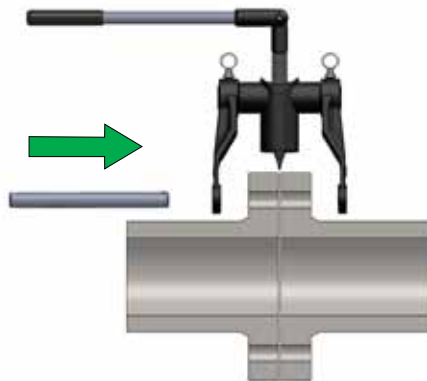

**3) Flange spreading**



**The operator MUST read this manual prior to using the tools.**

## 5. EXAMINATION, MAINTENANCE AND STORAGE

Before and after using any Equalizer tool, ensure the full kit is available and check for any damage or wear.

Any missing or damaged items are to be replaced as soon as possible, prior to the tool being used again.

Store in a cool dry place and ensure all machined surfaces are greased

Grease all moving parts prior to use

---

## 6. MG7TM MINI-GAP FLANGE SPREADER

### 6.1 KIT COMPONENTS

---

- 1 x MG7TM Tool
- 1 x Ø 16mm (0.63") Spreading Bar
- 1 x Ø 20mm (0.79") Spreading Bar
- 1 x Instruction Manual

Product Code: MG7TMSTD



## 6.2 INSTALLATION AND OPERATION



Before attaching the tool, ensure at least two flange bolts remain in place, 180 degrees apart, with nuts loosened sufficiently enough for flange work to be carried out. These bolts will reduce lateral flange movement during flange spreading and will help support the unit.



1. Do not extend the handle or use the smaller spreading bar as an extension bar.

Be aware of the dangers of breaking sealed flange joints. Ensure that relevant risk assessments have been carried out for the task and your company procedures must be followed at all times.

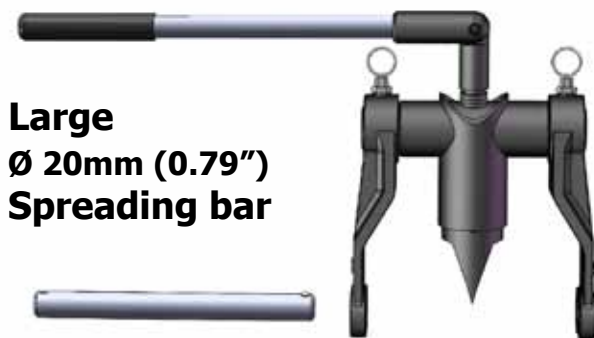

**Large**  
**Ø 20mm (0.79")**  
**Spreading bar**

**Tool Configuration 1**

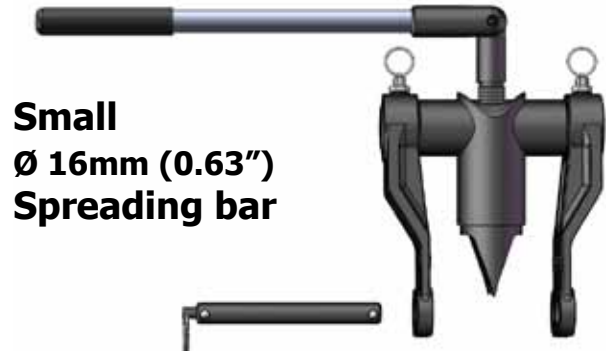

**Small**  
**Ø 16mm (0.63")**  
**Spreading bar**

**Tool Configuration 2**

2. Choose the suitable configuration for the size and class of flange joint you wish to separate. See the application charts found on page 14 - 19 of this manual.

The spreading bars are designed to only fit the correct flange specification. No two spreading bars can fit the same stud hole.





The flange bolting should be disassembled as per your company's procedures and risk assessment.

3. Place the tool over the flange joint and align with the desired stud hole.

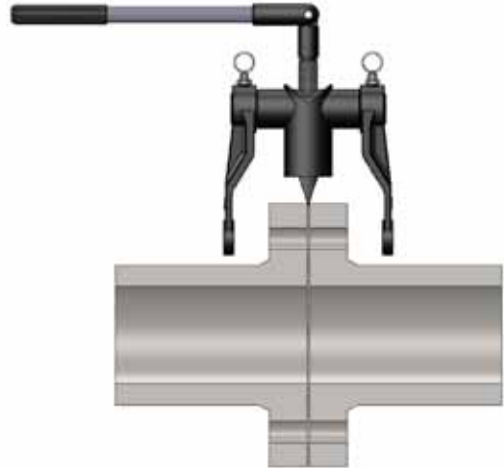

4. Engage the spreading bar through the leg of the tool and the flange stud hole.

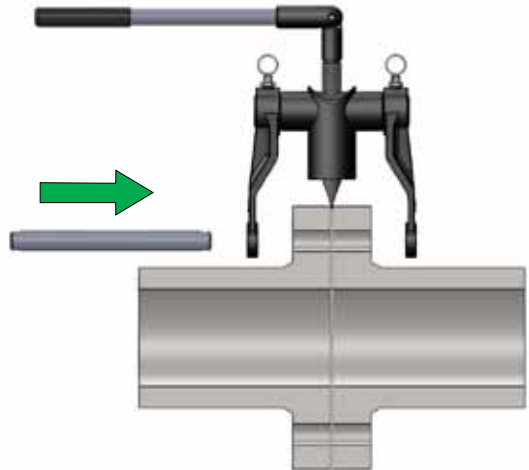

Do not hammer or use excessive force to fit the spreading bar. The bar should be fitted by hand.

5. Take care to ensure the spreading bar is correctly fitted through the second leg of the tool. Check the wedge is positioned in the gap between the flange faces.

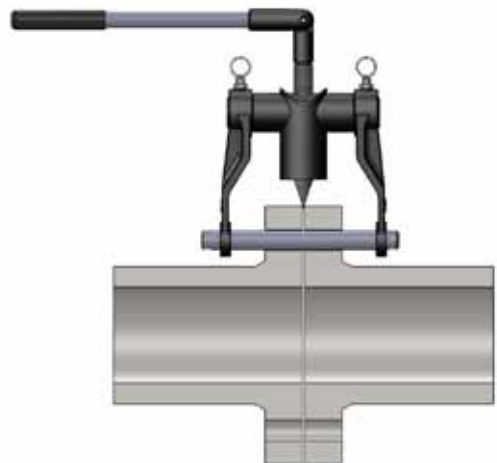

6. It is strongly recommended that two MG7™ Tools are used on the flange joint positioned 180 degrees apart.

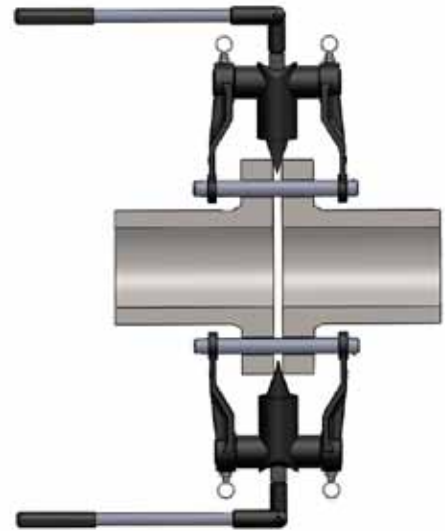

## Flange separation



## Flange spreading and seal removal



7. Turn each opposing tool a half turn at a time until the desired gap is achieved. Care must be taken to ensure the force is applied evenly.

The maximum spreading distance for the MG7™ is 27mm.

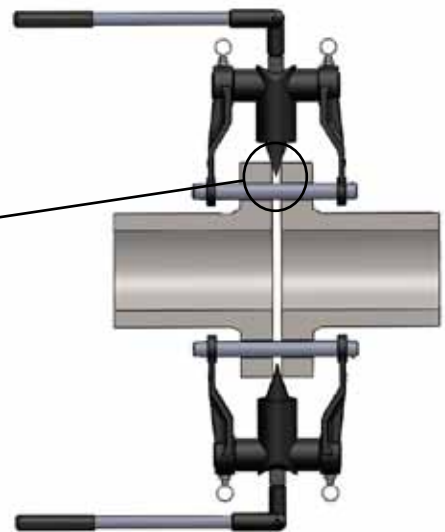
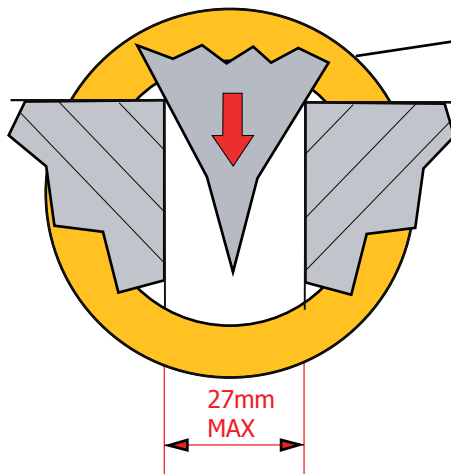

## 6.3 MAINTENANCE AND LUBRICATION

Before and after each job, the Equalizer Mini-Gap mechanical tool kit must be checked to establish that they are complete and all items must be examined to ensure that they are serviceable.

At regular intervals, and specifically after being exposed to salt water, Mini-Gap mechanical tools should be dismantled and lubricated as follows:

1. Lay the tool on a bench or flat surface with the right hand side face down.

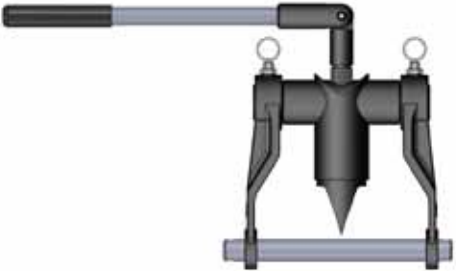

2. Pull the spreading bar out of the tool.



3. To Remove the left hand cast leg from the tool. Pull the spring loaded plunger to release the leg.



4. Remove the right hand cast leg from the tool.



- 5.** Drive the handle so that the splitter wedge moves down. Then remove the Splitter wedge and Thrust bearing from the tool.



- 6.** Fully unscrew the drive screw. Remove the main body and the outer sleeve from the tool.

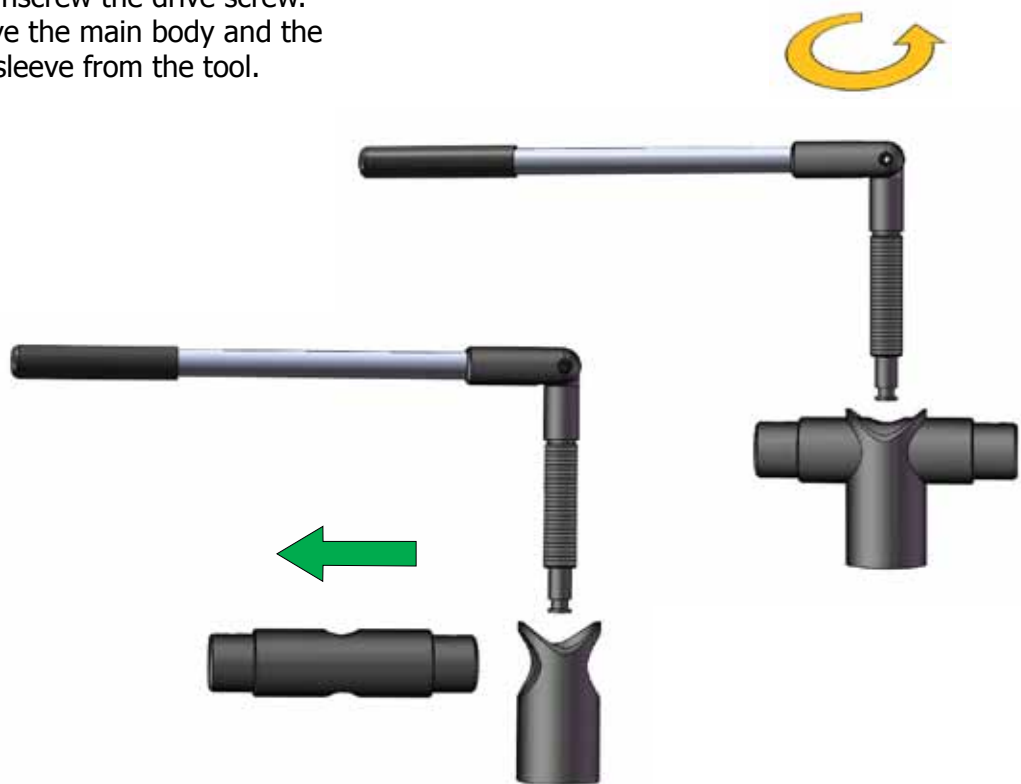

7. Apply grease to the drive screw. Clean all components and inspect for wear and damage. Replace all worn and damaged components with genuine Equalizer spares.

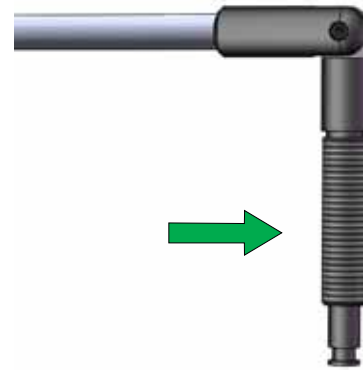

8. Reassemble by reversing the disassembly procedure (steps 2 to 7).



Note: it is recommended that the tool is wiped down with a clean rag and WD40 or similar cleaning fluid to remove any dirt or grit and then liberally greased with a high load bearing grease (Rocol sapphire high load 2 or similar)



## 6.3 PARTS LIST

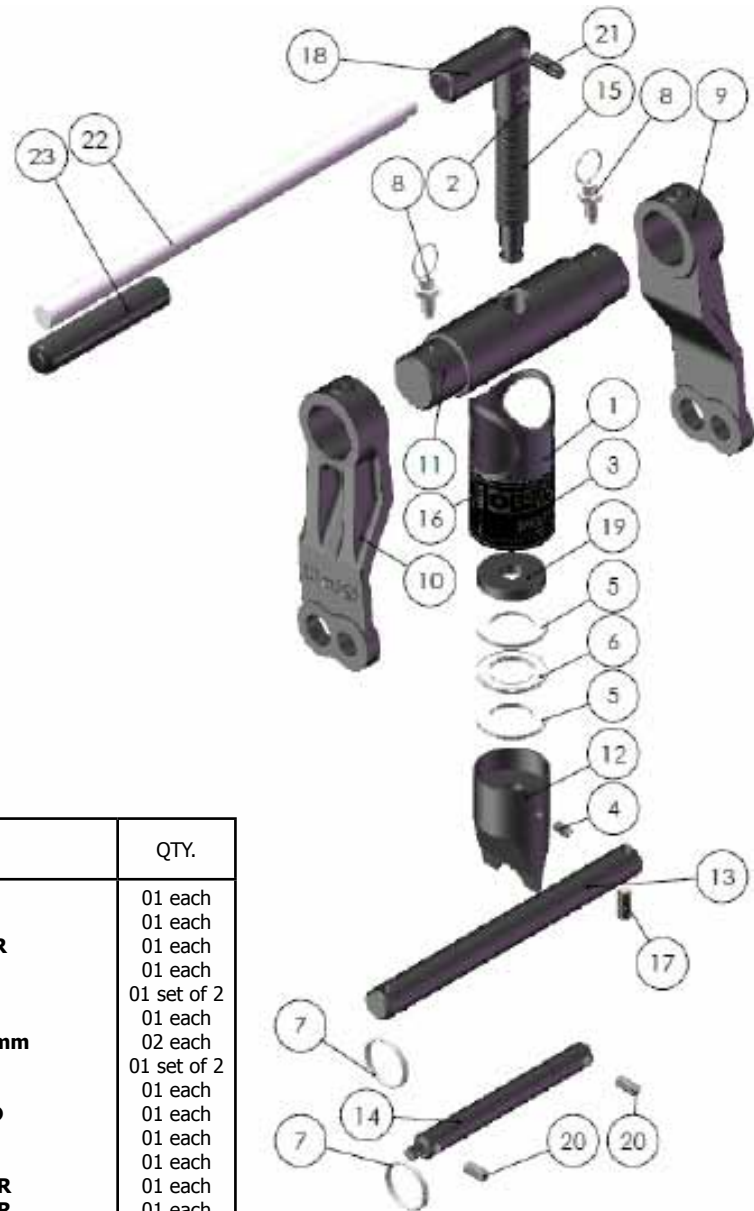

ITEM NO.	PART NO	DESCRIPTION	QTY.
01		<b>READ INST. STICKER</b>	01 each
02		<b>QC SEALED STICKER</b>	01 each
03		<b>MG7™ WRAP STICKER</b>	01 each
04	<b>301301-01</b>	<b>M6X12 GRUB SCREW</b>	01 each
05	<b>313401-01</b>	<b>THRUST WASHER</b>	01 set of 2
06	<b>313501-01</b>	<b>THRUST RACE</b>	01 each
07	<b>403102-01</b>	<b>SPLIT RING 1 1/4" 32mm</b>	02 each
08	<b>632001-01</b>	<b>M8 SPRING PLUNGER</b>	01 set of 2
09	<b>740101-01</b>	<b>CAST LEG LEFT HAND</b>	01 each
10	<b>740201-01</b>	<b>CAST LEG RIGHT HAND</b>	01 each
11	<b>740301-01</b>	<b>MAIN BODY</b>	01 each
12	<b>740401-01</b>	<b>SPLITTER WEDGE</b>	01 each
13	<b>740501-01</b>	<b>LARGE SPREADING BAR</b>	01 each
14	<b>740601-01</b>	<b>SMALL SPREADING BAR</b>	01 each
15	<b>740701-01</b>	<b>DRIVE SCREW</b>	01 each
16	<b>740901-01</b>	<b>OUTER SLEEVE</b>	01 each
17	<b>741101-01</b>	<b>8 MM PLUNGER</b>	01 each
18	<b>740801-01</b>	<b>HANDLE PLUG</b>	01 each
19	<b>742001-01</b>	<b>BEARING WASHER</b>	01 each
20	<b>742101-01</b>	<b>7 MM PLUNGER</b>	01 set of 2
21	<b>743101-01</b>	<b>COILED SPRING PIN</b>	01 each
22	<b>373401-01</b>	<b>HANDLE ROD</b>	01 each
23	<b>306502-01</b>	<b>HANDLE GRIP</b>	01 each

## 6.4 WEIGHTS AND DIMENSIONS

MG7™ MINI-GAP FLANGE SPREADER

= 5 kg (11.02 lb)

GROSS KIT WEIGHT

= 5.5 kg (12.13 lb)

Packaging Dimensions: 500mm x 315mm x 115 mm (19.7" x 12.4" x 4.5")

### Large Ø20mm (0.79") spreading bar

#### TOOL CONFIGURATION 1 RETRACTED WEDGE

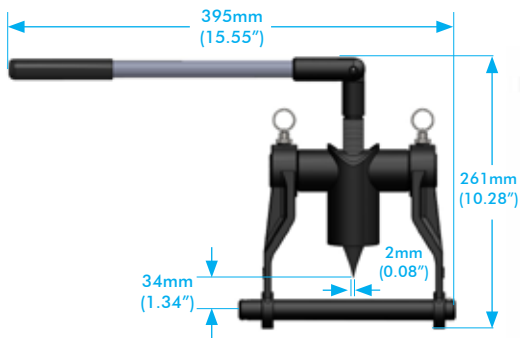

#### TOOL CONFIGURATION 1 ADVANCED WEDGE

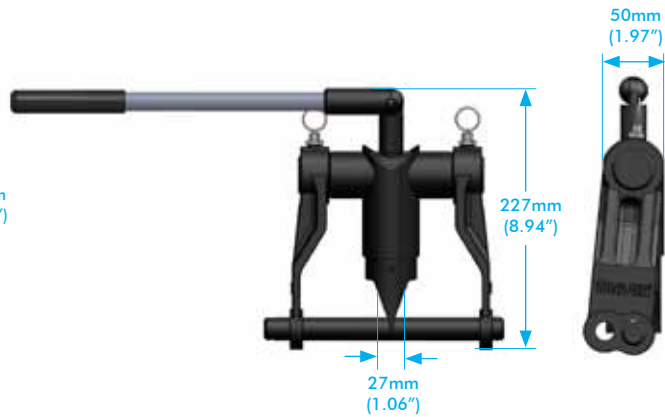

### Small Ø16mm (0.63") spreading bar

#### TOOL CONFIGURATION 2 RETRACTED WEDGE

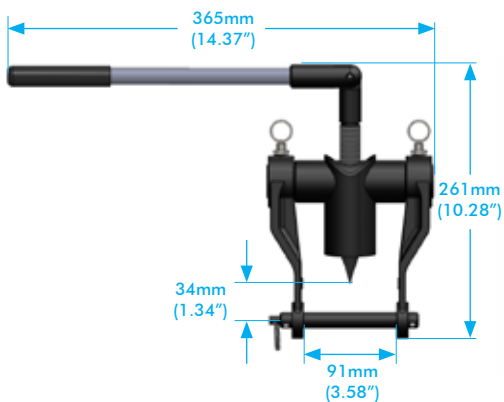

#### TOOL CONFIGURATION 2 ADVANCED WEDGE

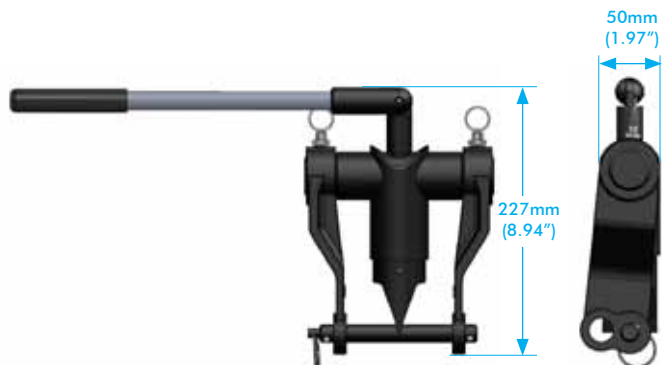

## 7. RANGE OF APPLICATION CHARTS

Use the charts on the following pages to determine which spreading bar is suitable for a particular flange.

The charts are categorised as per flange type.

<b>ASME</b>	B16.5 Weldneck, Threaded, Slip-on and Blind flanges	→	see page 15
	B16.5 Socket welded	→	see page 15
	B16.5 Long welding neck flange	→	see page 16
	B16.5 Lapped flange	→	see page 16
	B16.47 Weldneck and Blind flanges	→	see page 17
<b>ANSI</b>	Reducing	→	see page 17
	Orifice - Weldneck flange	→	see page 18
	Orifice - Slip-on and Threaded flanges	→	see page 18
<b>BS 10</b>		→	see page 19

**Large  
Spreading bar**



**Tool Configuration 1**

**Small  
Spreading bar**



**Tool Configuration 2**



### ASME B16.5 Weldneck, threaded, slip-on and blind flanges

NPS	Class						
	150	300	400	600	900	1500	2500
1/2"	Small Bar	Small Bar	Small Bar	Small Bar	Large Bar	Large Bar	Large Bar
3/4"	Small Bar	Small Bar	Small Bar	Small Bar	Large Bar	Large Bar	Large Bar
1"	Small Bar	Small Bar	Small Bar	Small Bar	Large Bar	Large Bar	Large Bar
1 1/4"	Small Bar	Small Bar	Small Bar	Small Bar	Large Bar	Large Bar	Large Bar
1 1/2"	Small Bar	Large Bar	Large Bar	Large Bar	Large Bar	Large Bar	Large Bar
2"	Small Bar	Large Bar	Large Bar	Large Bar	Large Bar	Large Bar	Large Bar
2 1/2"	Small Bar	Large Bar	Large Bar	Large Bar	Large Bar	Large Bar	Large Bar
3"	Small Bar	Large Bar	Large Bar	Large Bar	Large Bar	Large Bar	Large Bar
3 1/2"	Small Bar	Large Bar	Large Bar	Large Bar	Large Bar	Large Bar	
4"	Small Bar	Large Bar	Large Bar	Large Bar	Large Bar	Large Bar	
5"	Large Bar	Large Bar	Large Bar	Large Bar	Large Bar		
6"	Large Bar	Large Bar	Large Bar	Large Bar	Large Bar		
8"	Large Bar	Large Bar	Large Bar	Large Bar	Large Bar		
10"	Large Bar	Large Bar	Large Bar	Large Bar			
12"	Large Bar	Large Bar	Large Bar	Large Bar			
14"	Large Bar	Large Bar	Large Bar				
16"	Large Bar	Large Bar	Large Bar				
18"	Large Bar	Large Bar	Large Bar				
20"	Large Bar	Large Bar					
22"							
24"	Large Bar	Large Bar					
26"	Large Bar						
28"	Large Bar						
30"	Large Bar						

### ASME B16.5 Socket welded flange

NPS	Class			
	150	300	600	1500
1/2"	Small Bar	Small Bar	Small Bar	Large Bar
3/4"	Small Bar	Small Bar	Small Bar	Large Bar
1"	Small Bar	Small Bar	Small Bar	Large Bar
1 1/4"	Small Bar	Small Bar	Small Bar	Large Bar
1 1/2"	Small Bar	Small Bar	Small Bar	Large Bar
2"	Small Bar	Small Bar	Small Bar	Large Bar
2 1/2"	Small Bar	Large Bar	Large Bar	Large Bar
3"	Small Bar	Large Bar	Large Bar	

### ASME B16.5 Long welding neck flange

NPS	Class			
	150	300	600	900
1/2"	Small Bar	Small Bar	Small Bar	Large Bar
3/4"	Small Bar	Small Bar	Small Bar	Large Bar
1"	Small Bar	Small Bar	Small Bar	Large Bar
1 1/4"	Small Bar	Small Bar	Small Bar	Large Bar
1 1/2"	Small Bar	Small Bar	Small Bar	Large Bar
2"	Small Bar	Small Bar	Small Bar	Large Bar
2 1/2"	Small Bar	Large Bar	Large Bar	Large Bar
3"	Small Bar	Large Bar	Large Bar	Large Bar
3 1/2"	Small Bar	Large Bar	Large Bar	Large Bar
4"	Small Bar	Large Bar	Large Bar	Large Bar
5"	Large Bar	Large Bar	Large Bar	Large Bar
6"	Large Bar	Large Bar	Large Bar	Large Bar
8"	Large Bar	Large Bar	Large Bar	Large Bar
10"	Large Bar	Large Bar	Large Bar	
12"	Large Bar	Large Bar	Large Bar	
14"	Large Bar	Large Bar		
16"	Large Bar	Large Bar		
18"	Large Bar	Large Bar		
20"	Large Bar	Large Bar		
22"				
24"	Large Bar	Large Bar		
26"	Large Bar			
28"	Large Bar			
30"	Large Bar			

### ASME B16.5 Lapped flange

NPS	Class						
	150	300	400	600	900	1500	2500
1/2"	Small Bar	Small Bar	Small Bar	Small Bar	Large Bar	Large Bar	Large Bar
3/4"	Small Bar	Small Bar	Small Bar	Small Bar	Large Bar	Large Bar	Large Bar
1"	Small Bar	Small Bar	Small Bar	Small Bar	Large Bar	Large Bar	Large Bar
1 1/4"	Small Bar	Small Bar	Small Bar	Small Bar	Large Bar	Large Bar	Large Bar
1 1/2"	Small Bar	Small Bar	Small Bar	Small Bar	Large Bar	Large Bar	Large Bar
2"	Small Bar	Small Bar	Small Bar	Small Bar	Large Bar	Large Bar	Large Bar
2 1/2"	Small Bar	Large Bar	Large Bar	Large Bar	Large Bar	Large Bar	
3"	Small Bar	Large Bar	Large Bar	Large Bar	Large Bar	Large Bar	
3 1/2"	Small Bar	Large Bar	Large Bar	Large Bar	Large Bar		
4"	Small Bar	Large Bar	Large Bar	Large Bar	Large Bar		
5"	Large Bar	Large Bar	Large Bar	Large Bar			
6"	Large Bar	Large Bar	Large Bar	Large Bar			
8"	Large Bar	Large Bar	Large Bar	Large Bar			
10"	Large Bar	Large Bar	Large Bar				
12"	Large Bar	Large Bar					

## ASME B16.47 Weldneck and blind flanges

Class	
NPS	150
26"	Large Bar
28"	Large Bar
30"	Large Bar
32"	Large Bar
34"	Large Bar
36"	Large Bar
42"	Large Bar
48"	Large Bar
54"	Large Bar
60"	Large Bar

## ANSI Reducing

Class							
NPS	150	300	400	600	900	1500	2500
1/2"	Small Bar	Small Bar	Small Bar	Small Bar	Large Bar	Large Bar	Large Bar
3/4"	Small Bar	Small Bar	Small Bar	Small Bar	Large Bar	Large Bar	Large Bar
1"	Small Bar	Small Bar	Small Bar	Small Bar	Large Bar	Large Bar	Large Bar
1 1/4"	Small Bar	Small Bar	Small Bar	Small Bar	Large Bar	Large Bar	Large Bar
1 1/2"	Small Bar	Small Bar	Small Bar	Small Bar	Large Bar	Large Bar	Large Bar
2"	Small Bar	Small Bar	Small Bar	Small Bar	Large Bar	Large Bar	Large Bar
2 1/2"	Small Bar	Large Bar	Large Bar	Large Bar	Large Bar	Large Bar	Large Bar
3"	Small Bar	Large Bar	Large Bar	Large Bar	Large Bar	Large Bar	Large Bar
3 1/2"	Small Bar	Large Bar	Large Bar	Large Bar	Large Bar	Large Bar	
4"	Small Bar	Large Bar	Large Bar	Large Bar	Large Bar	Large Bar	
5"	Large Bar	Large Bar	Large Bar	Large Bar	Large Bar		
6"	Large Bar	Large Bar	Large Bar	Large Bar	Large Bar		
8"	Large Bar	Large Bar	Large Bar	Large Bar	Large Bar		
10"	Large Bar	Large Bar	Large Bar	Large Bar			
12"	Large Bar	Large Bar	Large Bar	Large Bar			
14"	Large Bar	Large Bar	Large Bar				
16"	Large Bar	Large Bar	Large Bar				
18"	Large Bar	Large Bar	Large Bar				
20"	Large Bar	Large Bar					
22"	Large Bar	Large Bar					
24"	Large Bar	Large Bar					
26"	Large Bar						
28"	Large Bar						
30"	Large Bar						

### ANSI Orifice - Weldneck flange

NPS	Class					
	300	400	600	900	1500	2500
1"	Small Bar	Small Bar	Small Bar	Large Bar	Large Bar	Large Bar
1 1/2"	Large Bar	Large Bar	Large Bar	Large Bar	Large Bar	Large Bar
2"	Small Bar	Small Bar	Small Bar	Large Bar	Large Bar	Large Bar
2 1/2"	Large Bar	Large Bar	Large Bar	Large Bar	Large Bar	Large Bar
3"	Large Bar	Large Bar	Large Bar	Large Bar	Large Bar	Large Bar
4"	Large Bar	Large Bar	Large Bar	Large Bar	Large Bar	
6"	Large Bar	Large Bar	Large Bar	Large Bar		
8"	Large Bar	Large Bar	Large Bar	Large Bar		
10"	Large Bar	Large Bar	Large Bar			
12"	Large Bar	Large Bar	Large Bar			
14"	Large Bar	Large Bar				
16"	Large Bar	Large Bar				
18"	Large Bar	Large Bar				
20"	Large Bar					
22"	Large Bar					
24"	Large Bar					

### ANSI Orifice - Slip-on and Threaded flanges

NPS	Class
	300
1"	Small Bar
1 1/2"	Large Bar
2"	Small Bar
2 1/2"	Large Bar
3"	Large Bar
4"	Large Bar
6"	Large Bar
8"	Large Bar
10"	Large Bar
12"	Large Bar
14"	Large Bar
16"	Large Bar
18"	Large Bar
20"	Large Bar
22"	Large Bar
24"	Large Bar

