



Pneutorque® Standard Series Models to 3400 N.m, Single Speed

Based on the original Pneutorque, the 'Standard Series' Range is a direct result of over 40 years of refinement and development necessary to keep pace with industry's requirements today.

In use on many thousands of applications worldwide, Pneutorque Wrenches continue to represent the foundation of Norbar's powered tool range.

- Models available for almost every bolting application.
- Forward and reverse operation.
- Low operator fatigue – quiet, non impacting or pulsing.
- Repeatability of $\pm 5\%$.
- Other reaction styles can be designed to suit specific applications.
- Electronic torque transducers can be fitted for precise torque monitoring.

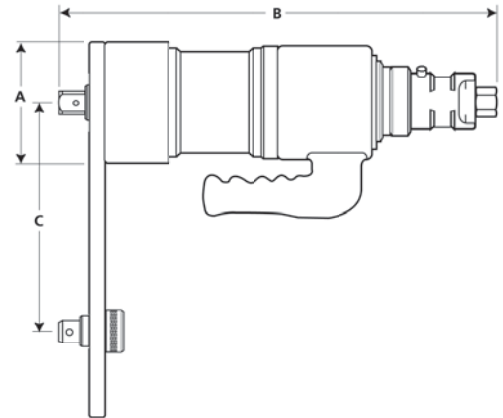

Standard Series to 3400 N.m, Single Speed

Model	Square Drive	Part No.	Range		Free Speed†	A	B	C min	C max	Tool Weight	Reaction Weight
	in		N.m	lbf.ft							
PT 1	3/4	16031	160-680	120-500	30	108	368	83	217	10.6	2.2
PT 1	1	16011	160-680	120-500	30	108	373	83	217	10.6	2.2
PT 1A	3/4	16098	270-1200	200-900	15	105	368	83	217	11.1	2.2
PT 1A	1	16097	270-1200	200-900	15	108	373	83	217	11.1	2.2
PT 2	1	16013	515-1700	380-1250	9	108	373	83	217	11.1	2.2
PT 5	1	16015	880-3400	650-2500	5	119	424	83	264	14	2.5
PT 6	1 1/2	16017	880-3400	650-2500	5	119	430	83	264	14	2.5

† Speed at maximum air pressure.

Pneutorque® Standard Series Models to 3400 N.m, Two Speed

Two Speed models offer all of the advantages of single speed versions but with the additional benefit of a run down speed five times greater than the final torque speed.

- Models available for almost every bolting application.
- Forward and reverse operation.
- Low operator fatigue – quiet, no impacting or pulsing.
- Repeatability of $\pm 5\%$.
- Other reaction styles can be designed to suit specific applications.
- Electronic torque transducers can be fitted for precise torque monitoring.



PT5 AUT

PT2 MTS

Standard Series to 3400 N.m, Manual Two Speed

Model	Square Drive	Part No.	Range		Free Speed†	A	B	C min	C max	Tool Weight	Reaction Weight
	in		N.m	lbf.ft							
PT 1 MTS	3/4	16031.MTS	160-680	120-500	150	108	454	83	217	14.1	2.2
PT 1 MTS	1	16011.MTS	160-680	120-500	150	108	459	83	217	14.1	2.2
PT 1A MTS	3/4	16098.MTS	270-1200	200-900	75	108	454	83	217	14.3	2.2
PT 1A MTS	1	16097.MTS	270-1200	200-900	75	108	459	83	217	14.6	2.2
PT 2 MTS	1	16013.MTS	515-1700	380-1250	45	108	459	83	217	14.6	2.2
PT 5 MTS	1	16015.MTS	880-3400	650-2500	25	119	510	86	264	17.5	2.5
PT 6 MTS	1 1/2	16017.MTS	880-3400	650-2500	25	119	516	86	264	17.5	2.5

Standard Series to 3400 N.m, Automatic Two Speed

Model	Square Drive	Part No.	Range		Free Speed†	A	B	C min	C max	Tool Weight	Reaction Weight
	in		N.m	lbf.ft							
PT 1 AUT	3/4	16031.AUT	160-680	120-500	150	108	437	83	217	14.1	2.2
PT 1 AUT	1	16011.AUT	160-680	120-500	150	108	442	83	217	14.1	2.2
PT 1A AUT	3/4	16098.AUT	270-1200	200-900	75	108	437	83	217	14.6	2.2
PT 1A AUT	1	16097.AUT	270-1200	200-900	75	108	442	83	217	14.6	2.2
PT 2 AUT	1	16013.AUT	515-1700	380-1250	45	108	442	83	217	14.6	2.2
PT 5 AUT	1	16015.AUT	880-3400	650-2500	25	119	493	86	264	17.5	2.5
PT 6 AUT	1 1/2	16017.AUT	880-3400	650-2500	25	119	499	86	264	17.5	2.5

†Speed at maximum air pressure and in high gear



Pneutorque® Standard Series Models to 100,000 N.m, Single Speed

- Models available for almost every bolting application, up to 100,000 N.m.
- Forward and reverse operation.
- Low operator fatigue – quiet, no impacting or pulsing.
- Repeatability of $\pm 5\%$.
- Other reaction styles can be designed to suit specific applications.
- Electronic torque transducers can be fitted for precise torque monitoring. See page 83.
- Models 13 and 14 supplied with blank reaction plate for fabrication to specific requirements.

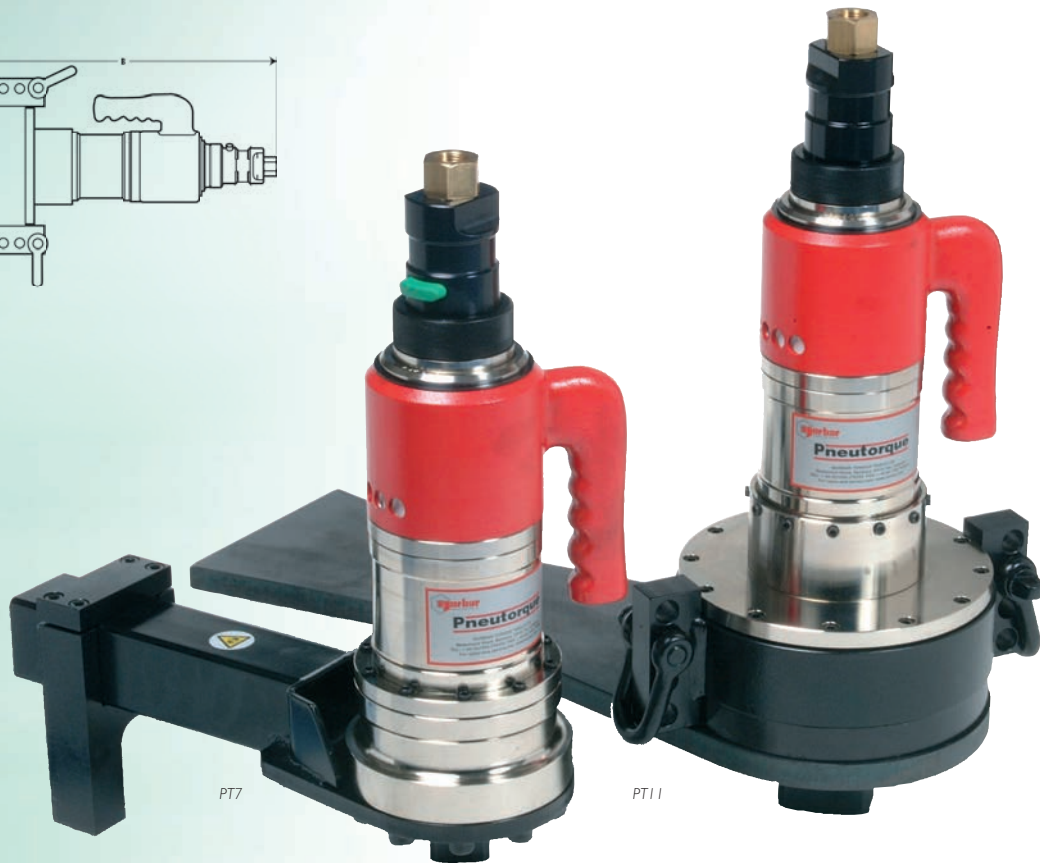
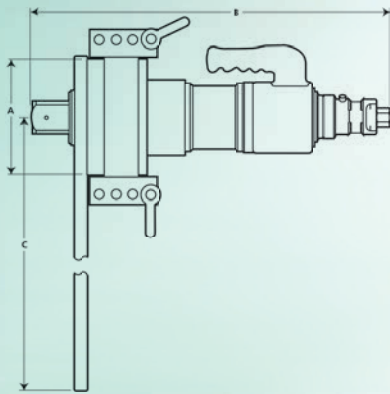

Standard Series to 100,000 N.m, Single Speed

Model	Square Drive	Part No.	Range		Free Speed†	A	B	C min	C max	Tool Weight	Reaction Weight
	in		N.m	lbf.ft							
PT 7	1½	16066	1762-6000	1300-4500	2.5	144	457	146	333	19.7	6.3
PT 9	1½	16072	2710-9500	2000-7000	1.8	184	452	169	351	24.4	8.3
PT 11	2½	16046	4400-20000	3250-14700	1.2	212	546.3	-	500	38.6	13.3
PT 12	2½	18086	9500-34000	7000-25000	0.5	240	593	Blank Plate		49.8	6.5
PT 13	2½	16052	13550-47000	10000-35000	0.3	315	629	Blank Plate		102.2	6.9
PT 14	3½	16045	22375-100000	16500-73500	0.2	315	726	Blank Plate		119.4	10.4

† Speed at maximum air pressure.

Pneutorque® Standard Series Models to 300,000 N.m, Two Speed

Two Speed Models offer all of the advantages of single speed versions but with the additional benefit of a run down speed five times greater than the final torque speed.

- Models available for almost every bolting and torque application, up to 300,000 N.m.
- Forward and reverse operation.
- Low operator fatigue – quiet, no impacting or pulsing.
- Repeatability of ±5%.
- Other reaction styles can be designed to suit specific applications.
- Electronic torque transducers can be fitted for precise torque monitoring. See page 83.
- Models 13 and 14 supplied with blank reaction plate for fabrication to specific requirements.



PT13 and PT14 are supplied on a trolley and with a Lubro Control Unit

Standard Series to 300,000 N.m, Manual Two Speed

Model	Square Drive	Part No.	Range		Free Speed [†]	A	B	C min	C max	Tool Weight	Reaction Weight
	in		N.m	lbf.ft							
PT 7 MTS	1½	16066.MTS	1762-6000	1300-4500	12.5	144	543	146	333	23.2	6.3
PT 9 MTS	1½	16072.MTS	2710-9500	2000-7000	9	184	538	169	351	27.9	8.3
PT 11 MTS	2½	16046.MTS	4400-20000	3250-14700	6	212	632	-	500	42.1	13.3
PT 12 MTS	2½	18086.MTS	9500-34000	7000-25000	2.5	240	679	Blank Plate		53.3	6.5
PT 13 MTS	2½	16052.MTS	13550-47000	10000-35000	1.5	315	716	Blank Plate		105.7	6.9
PT 14 MTS	3½	16045.MTS	22375-100000	16500-73500	1	315	800	Blank Plate		122.9	10.4
PT 18 MTS	-	16054.MTS	85000-300000	62500-220000	0.3	520	930	-		380	-

[†] Speed at maximum air pressure.

PT 18 part number does not include an output drive or reaction. These components will be engineered uniquely for each application.

Standard Series to 100,000 N.m, Automatic Two Speed

Model	Square Drive	Part No.	Range		Free Speed [†]	A	B	C min	C max	Tool Weight	Reaction Weight
	in		N.m	lbf.ft							
PT 7 AUT	1½	16066.AUT	1762-6000	1300-4500	12.5	144	526	146	333	23.2	6.3
PT 9 AUT	1½	16072.AUT	2710-9500	2000-7000	9	184	521	169	351	27.9	8.3

[†]Speed at maximum air pressure and in high gear