



MOTORISED TORQUE WRENCH LOADER



CONTENTS

Safety	2
Introduction	3
Parts Included	3
Accessories	3
Features & Functions	3
Installation	4
Motor Kit	4
Items Required	4
Location	4
Connecting Control Box	4
Mains Plug Fitting	5
Mains Voltage Selection	5
Torque Measurement	5
Initial Free Run Test	5
Operating Instructions	6
Locating a Torque Wrench	6
Using the Motorised System	6
Emergency Stop	6
Overload	7
Hints on Torque Wrench Testing	7
Maintenance	8
Cleaning	8
Disposal	8
Specifications	8
Declaration of Conformity	9
Appendix A - Fitting Motor Kit	10
Removing the Handwheel	10
Removing Input Shaft Blanking Plate	10
Fitting of Motor Assembly	10
Motor Assembly Orientation on Torque Wrench Loader	11
Placing Motor Behind Torque Wrench Loader	11
Appendix B - Trouble shooting	12
System Not Working	12
Manual Release of Torque	12

SAFETY

- Always read and understand the manual fully before use.
- Train operating personnel to use the Motorised Torque Wrench Loader in a safe manner.
- The ISO 1500 is heavy. Take care when installing. Only lift by the solid metalwork.
- Ensure the operating area is capable of taking the weight of the ISO 1500.
- Trapping hazard - Keep hand and loose clothing away from the torque wrench during use.
- To avoid damage to the torque wrench under test do not exceed the wrench set torque value.
- To avoid damage to the transducer do not exceed the maximum capacity.
- Never exceed the maximum torque capacity of the ISO 1500 (1500 N·m / 1100 lbf·ft).
- Do not operate without a torque measurement system connected and working.
- The ISO 1500 is designed for testing torque tools, do not use for other purposes.
- The base of the control box may be warm to the touch.
- This is a powerful torque application system. Care **MUST** be taken or damage may result to the torque wrench, the torque measurement system, the torque wrench loader or operating personnel.

INTRODUCTION

The Motorised Torque Wrench Loader allows torque wrenches to be calibrated and tested in an accurate and repeatable way whilst reducing operator effort.

This manual covers 60193 & 60194 only.

Parts Included

Part Number	Description	Definition	Items Included
60193	ISO 1500 Motorised Torque Wrench Loader	Fully fitted unit	Part Number 60194 and 60118. With motor fitted to loader.
60194	Motor kit for a torque wrench loader.	The parts required to motorise a torque wrench loader.	Control box, motor assembly, lead to ETS / DTS (Part 61093), lead to T-Box / TTT / TST / Pro-Log (Part 60237), fitting tools manual (Part 34243) & mains lead.
60118	Torque wrench loader.	The mechanical loading rig (ISO 1500)	Loading rig with handwheel, reaction post assembly, transducer collars & square adapters.
-	Torque measurement system.	Norbar ETS, DTS, Pro-Log, TST, TTT or T-Box.	-

Accessories

Accessories Available	Part Number
Norbar torque measurement system.	Consult Norbar
Reaction Plate for small torque wrenches. (Wrench length 100mm to 180mm).	20588

NOTE: 20588 is fitted to pre-drilled mounting holes (see drawing on page 4). Loaders made before 1 September 1995 will need these holes adding.

FEATURES AND FUNCTIONS

- Motor kit easily fitted to Norbar 1500 loader.
- Assists calibration in accordance with BS EN ISO 6789:2003 and American military standard GGG-W-686.
- Retains the benefits of the standard torque wrench loader.
- Ergonomically designed speed control joy stick for accurate applied torque control.
- Safety transducer overload feature if used with compatible Norbar measurement system.
- Automatic motor stop without operator presence. Emergency stop override.

IMPORTANT: IF THE 'RED' LIGHT SHOWS REFER TO THE TROUBLE SHOOTING SECTION IN APPENDIX B.



INSTALLATION

NOTE: If the equipment is used in a manner not specified by the manufacturer, the protection provided by the equipment may be impaired.

Motor Kit

For 'Motor Kit for Torque Wrench Loader' (Part Number 60194) connect the motor to your existing Torque Wrench Loader, see Appendix A. (Page 10)

Items Required

Norbar torque transducer to suit capacity of test with suitable torque display instrument.

Refer to the operator's manuals for both the Torque Wrench Loader and torque measurement system.

It is possible to operate without a compatible Norbar torque measurement system, but this is not recommended as there is no transducer overtorque protection.

Location

Ensure location can cope with loader weight. Locate on a level surface at a comfortable working height.

Place torque measurement system on the left hand side next to the transducer.

Place the control box in a convenient location for easy operation.

Ensure the Torque Wrench Loader can still rotate through 90° (if applicable).



FIGURE 1 – Torque Measurement System



FIGURE 2 – Control Box

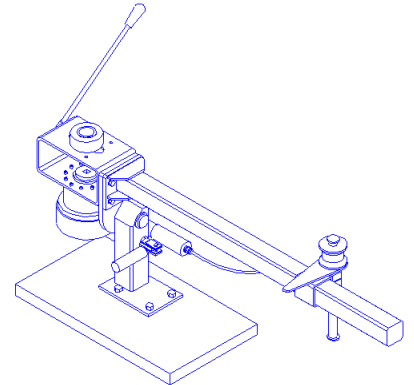

FIGURE 3 – Torque Wrench Loader

Connecting Control Box

1. Place flying lead from the motor into 'MOTOR' socket on control box back panel.
2. It is recommended that a compatible torque measurement system is used to facilitate transducer overload protection. Two leads are supplied for either ETS/DTS or TST/TTT connection.
 - a) **For ETS / DTS Overload Protection:**
Select lead with 25 way socket & 25 way plug.
Connect 25 way socket into 'ANCILLARIES' on control box.
Connect 25 way plug to ancillaries of ETS or DTS.
Use key switch on back panel to select 'ETS/DTS'.
 - b) **For T-Box / TST / TTT / Pro-Log Overload Protection:**
Select lead with 25 way socket & 15 way plug.
Connect 25 way socket into 'ANCILLARIES' on control box.
Connect 15 way plug to ancillaries of TST, TTT or Pro-Log.
Use key switch on back panel to select 'TST/TTT'.
 - c) **No Overload Protection:**
If a compatible torque measurement system is not to be used, the 25 way to 25 way lead will still need to be attached to the control box to enable the system.

Mains Plug Fitting

If a mains plug is not fitted, follow the plug's own instructions. The following may be useful:

BROWN-LIVE

BLUE-NEUTRAL

GREEN / YELLOW-EARTH



WARNING! IT IS IMPORTANT THAT LIVE, NEUTRAL AND EARTH ARE ALL CONNECTED BETWEEN THE MOTORISED TORQUE WRENCH LOADER AND THE MAINS SUPPLY. IF NO EARTH IS AVAILABLE (2 WIRE MAINS SUPPLY) IT IS RECOMMENDED THAT A SEPARATE EARTH IS CONNECTED BETWEEN THE CONTROL BOX AND A SUITABLE EARTH.

If the plug has an internal fuse, a 1 amp value is recommended.

Mains Voltage Selection

Ensure mains voltage is correctly set, the control box has a setting draw next to the mains input on back panel.

The orientation of this drawer can be changed by removing the drawer with a small flat screwdriver.

Align arrow of required voltage with marker.

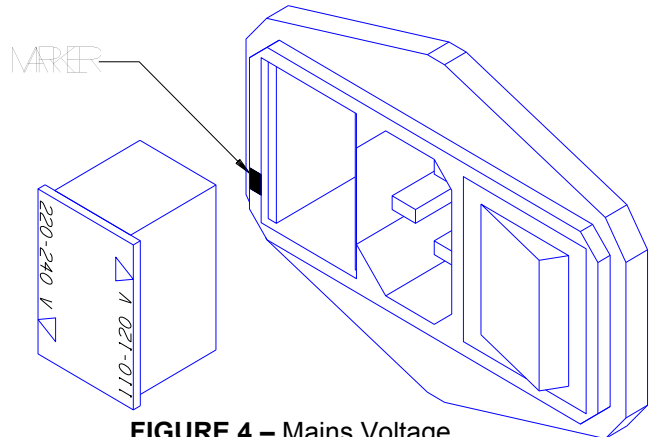

FIGURE 4 – Mains Voltage

Torque Measurement

Use parts supplied with Torque Wrench Loader, torque measurement system and transducer.

Refer to relevant operator's manual for torque measurement system and transducer to be used.

Select the lowest capacity torque transducer to cover the wrench to be tested.

Mount the male square of the transducer into the female square of the gear box, use adaptors to suit. A 1" square drive transducer will fit directly, others will require 1/4", 3/8" or 1/2" adaptor.

The appropriate locating collar should be placed over the top of the transducer and locked by rotating through 90 degrees.

Connect a transducer lead from the transducer to the instrument.

Ensure the instrument functions correctly. (If in doubt see operators manual).

Initial Free Run Test

With electrical supplies to the system and mains switches 'ON'. The GREEN LED will light.

Press the 'SET' button on the back panel to initialise the system. The 'RED' LED will extinguish, if not refer to Appendix B - Trouble Shooting. (Page 12)

**NOTE: PULL paddle to rotate the final drive anti-clockwise - DIRECTION A.
PUSH paddle to rotate the final drive clockwise - DIRECTION B.**

OPERATING INSTRUCTIONS

Locating a Torque Wrench

Please refer to Torque Wrench Loader operator's manual.
Select the correct adapter to place the torque wrench drive into transducer.

Set the reaction post position on the reaction arm so it is in the middle of the torque wrench handle.



FIGURE 5

Set the reaction post height to ensure the wrench handle is parallel to the reaction arm.

If the Torque Wrench is too small for the reaction arm use reaction plate option (Part 20588).

Using the Motorised System

The large gear box ratio makes movement in the output drive difficult to detect.
Use the 'A' and 'B' arrows on the control box and gearbox output as an indication.

For clock-wise calibration 'A' indicates direction to apply force & 'B' indicates direction to release force.

- a) **Pull** paddle to rotate torque wrench loader in direction **A** (anticlockwise).

The more the paddle is moved, the faster the loader will rotate.

Release paddle to stop rotation.
Paddle will automatically return to the 'STOP' position.

- b) **Push** paddle to rotate torque wrench loader in direction **B** (clockwise).

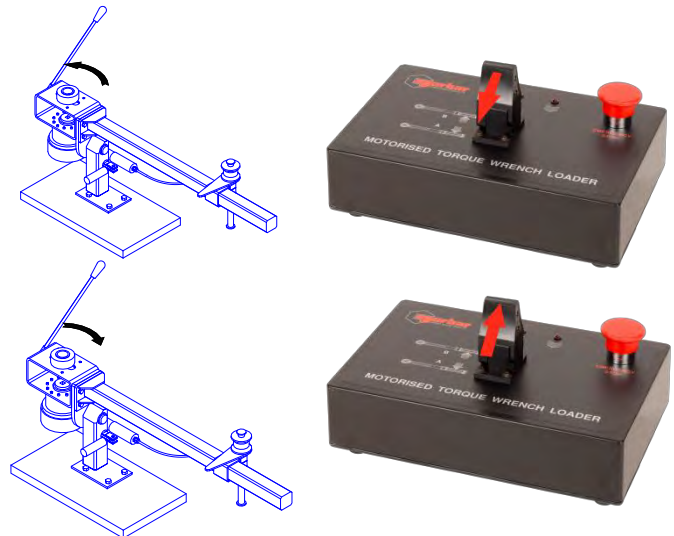

FIGURE 6 – Clockwise & Anti-clockwise Operation

TIP: In the case of a ratchet wrench, with push through square drives, it is important to ensure the square is operating on the correct side of the ratchet.

Emergency Stop

Press the RED 'EMERGENCY STOP' button to STOP the system. Remove the cause of the problem.
Press the 'SET' button on the back panel to initialise the system.

Overload

System	Overload action
ETS DTS	<p>The overload is activated at 150% (N·m transducer) or 120% (lbf·ft transducer).</p> <p>When activated the system will stop and the RED LED illuminate.</p> <p>To release the overload <u>PRESS AND HOLD</u> the 'SET' button on the back panel and move the paddle in the required direction.</p> <p>It is only possible to release the torque and not go further into overload.</p>
T-Box TTT TST Pro-Log	<p>The overload is activated by the 'HI' of the measurement system limit detector, refer to limit settings in measurement system manual.</p> <p>When the torque value reaches the HI (high) limit the system will stop and the RED LED illuminate. To release the overload either:</p> <p>a) Remove ancillaries lead from TST / TTT / Pro-Log. Press 'SET' on back panel. Move paddle and ensure the torque is decreasing. With overload removed replace the ancillaries lead.</p> <p>b) Turn key to 'ETS / DTS' position. <u>PRESS AND HOLD</u> 'SET' on back panel whilst moving paddle. Ensure the torque is decreasing. Turn key to 'TST / TTT' position.</p>

TIP: Place torque instrument into **TRACK** mode to ensure torque is decreasing.

Hints on Torque Wrench Testing

- On small torque wrenches the break point can be difficult to detect - care must be taken. It is recommended to use a long auto reset hold time, see measurement system manual. STOP loading when the measurement system detects the wrench break (the measuring system displays the <STOP> logo) even though the torque wrench click may not be heard. Use the first torque reading, as the second is the relaxed wrench reading.
- If down loading data to a computer or printer, false readings may occur when the wrench is being unloaded. To stop the false readings use a Print Inhibit Controller (ETS or DTS) or the LOG/NO LOG feature (Pro-Log) or PRINT/NO PRINT feature (TST or TTT) or SAVE / NO SAVE feature (T-Box).

MAINTENANCE

The Motorised Torque Wrench Loader is engineered for a long maintenance free life. Under normal operation maintenance is not required.

For maintenance and recalibration of the torque instrument and transducer refer to their manuals.

Cleaning

Do not use abrasives or solvent based cleaners. Norbar recommend a propriety brand of foam based fabric / vinyl cleaner. Use a soft cloth to avoid scratches.

Disposal



Do not dispose of this product with the general waste. To follow European Directive 2002/96/EC on WEEE (waste electrical and electronic equipment) this product must be sent to a recycling facility.

SPECIFICATIONS

Maximum Torque Output (With ISO 1500):	1500 N·m / 1100 lbf·ft
Voltage Requirements:	Selectable 110/120 Volts AC +/- 10 % or 220/240 Volts AC +/- 10% at 50/60 Hz.
Mains Power Fuse:	T500mA anti-surge for 220VAC. T1A anti-surge for 110VAC.
Internal Fuse:	3A Not operator replaceable.
Power Consumption:	85 W – maximum.
Mains Power Cable:	2.5 meters long.
Ancillaries Input:	25 Way 'D' plug.
Direction Of Torque Application:	Clockwise and Anticlockwise.
Overload (ETS or DTS):	1.55 V DC ± 5% as represented by torque signal.
Overload (T-Box, TST, TTT or Pro-Log):	5V DC as given by HI limit set.
Operating Temperature Range:	0 °C to +40 °C.
Storage Temperature Range:	-20 °C to +70 °C.
Maximum Operating Humidity:	80% Relative Humidity @30°C.
Weight:	Control Box 3.7 kg (including 3 leads) Motor Assembly 1.1 kg (including lead) Torque Wrench Loader 31 kg
Dimensions:	Control Box 145 mm high x 271 mm wide x 184 mm deep. Motor Assembly 47 mm high x 47 mm wide x 230 mm long.
Environment:	Indoor use within a light industrial environment. To environmental conditions Pollution Degree 2 & Installation Category (Overvoltage Category) II.

For ISO 1500 Torque Wrench Loader specification see manual part number 34126.

NOTE: If equipment is used in a manner not specified by the manufacturer, the protection provided by the equipment could be impaired.



Norbar Torque Tools Ltd
Beaumont Road
Banbury
Oxfordshire
OX16 1XJ
United Kingdom

Tel: + 44 (0) 1295 270333
Fax: + 44 (0) 1295 753643
E-mail: enquiry@norbar.com

Registered in England No.380480
VAT No. GB 119 1060 05

Declaration of Conformity

The following apparatus:

Motorised Torque Wrench Loader.
Part Numbers: 60193 & 60194.

Is in compliance with the protection requirements of the following directives:

Machinery Directive 2006/42/EC.
Low Voltage Equipment Directive 2006/95/EC.
Electromagnetic Compatibility Directive 2004/108/EC.

The following standards have been applied:

BS EN ISO 12100-1:2003 + A1:2009	Safety of machinery. Basic concepts, general principles for design. Basic terminology, methodology.
BS EN ISO 12100-2:2003 + A1:2009	Safety of machinery. Basic concepts, general principles for design. Technical principles.
BS EN 61010-1:2001	Safety requirements for electrical equipment for measurement, control and laboratory use. General requirements.
BS EN 61326-1:2006	Electrical equipment for measurement, control and laboratory use. EMC requirements. General requirements.

The basis on which conformity is being declared:

The technical documentation required to demonstrate that the apparatus meet the requirements of the above Directives has been compiled by the signatory below and is available for inspection by the relevant enforcement authorities. The CE mark was first applied in: 1998.

Signed:  **Full Name:** Trevor Mark Lester B.Eng.
Date: 8th January 2010 **Authority:** Compliance Engineer
Place: Norbar Torque Tools Ltd., Beaumont Road, Banbury, Oxfordshire, OX16 1XJ

www.norbar.com

United Kingdom • Australia • United States of America • New Zealand • Singapore • China

APPENDIX A - FITTING MOTOR KIT

This appendix describes how to fit a motor assembly onto the Torque Wrench Loader to create a Motorised Torque Wrench Loader.

Parts required:

1. Motor Kit. (Part No 60194)
2. Torque Wrench Loader. (Part No 60118)
3. Flat screwdriver.

1. Removing the Handwheel

Ensure there is no torque on the system before removing the handwheel.

Press the **OUTSIDE** of the plastic cap in the middle of the handwheel to reveal a fixing screw.

TIP: The use of a flat screwdriver may be useful.

Use the $\frac{3}{16}$ " hexagonal key to remove the screw, the handwheel will then slide off the shaft.

2. Removing Input Shaft Blanking Plate

Four small fixing screws can now be seen.

NOTE: Loaders produced before February 2011 use 4BA screws whilst those produced after February 2011 use M3 screws.

Use the 2.5mm hexagonal key to remove the four M3 fixing screws. (Use the 1/16" hexagonal key if loader is fitted with 4BA countersunk screws).

Remove the input shaft blanking plate.

Remove the spacer ring.

3. Fitting of Motor Assembly

Fit the thinner spacer ring supplied, then hold the motor assembly up to the gearbox input shaft.

Rotate assembly to ensure motor hexagonal drive fits gearbox input hexagonal, and the flat on the motor assembly is positioned as below.

With mounting holes lined up fit the four M3 x 16 LG mounting screws supplied using the 2.5mm hexagonal key. (If the loader pre-dates the February 2011 change then fit the four 4BA x $\frac{5}{8}$ " LG socket cap screws supplied using the $\frac{3}{32}$ " hexagonal key).

Ensure flat on motor assembly is as shown.

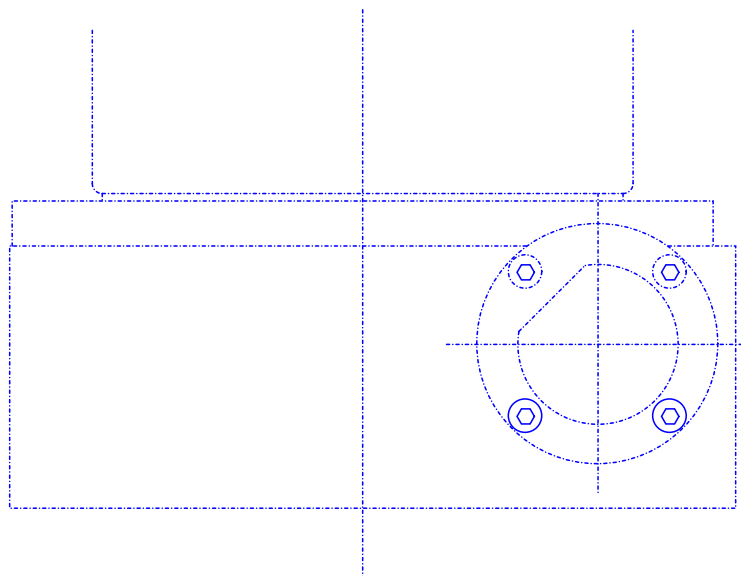

FIGURE 7

4. Motor Assembly Orientation on Torque Wrench Loader

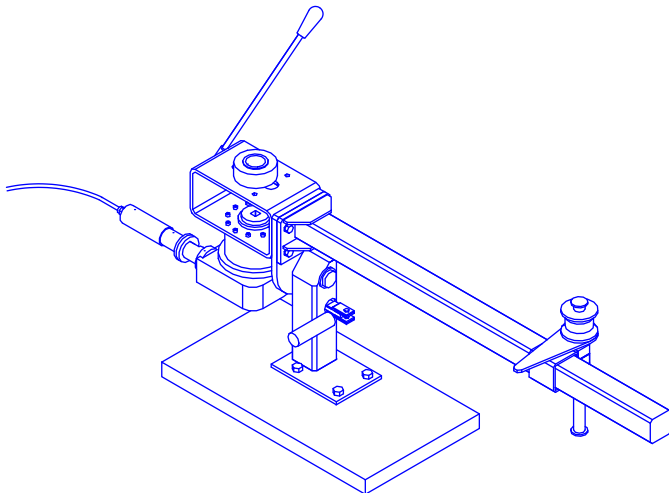

FIGURE 8 – Motor on Left

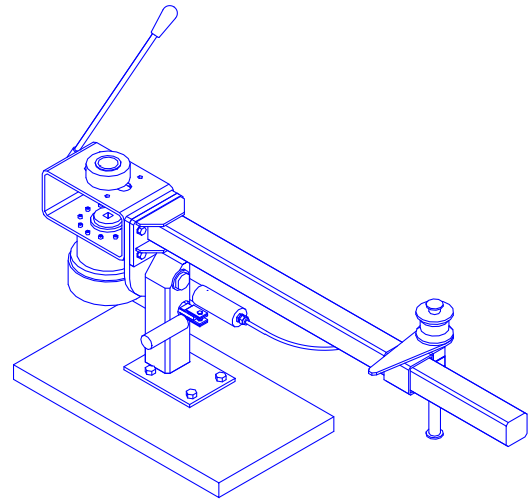

FIGURE 9 – Motor Behind

The assembly will now be as Figure 8 above.

To achieve a more compact design the motor can be placed behind the torque wrench loader as Figure 9, to accomplish this complete the following:

5. Placing Motor Behind Torque Wrench Loader

So that the motor assembly does not hit the Torque Wrench Loader the motor **MUST** be mounted on the gearbox as previously shown in step 3.



WARNING: TO CHANGE ORIENTATION IS A 2 PERSON TASK AS THE GEARBOX IS HEAVY (7.6 kg / 16.7 lb).

- A. Leaving 2 opposite screws in place, use the $\frac{5}{32}$ " hexagonal key to remove 10 fixing screws from the top of the gearbox.
- B. The second person should hold the gearbox up (Do not use the motor to take any weight).
- C. The remaining 2 screws can be removed and the gearbox will now drop free from the loader.
- D. Move the gearbox through 180° ensuring the flat on the motor assembly faces the Torque Wrench Loader.
- E. Replace all 12 screws by tightening each a little more in turn to a value of 9 N·m (7 lbf·ft).

APPENDIX B - TROUBLE SHOOTING

System Not Working

IS GREEN (POWER) LED ON? → NO



YES

IS RED (SET) LED ON? → YES



NO

DOES SYSTEM OPERATE? → NO

Reason	Action
No mains power.	Check mains supply.
Incorrect mains drawer selection.	Ensure drawer orientation is correct to suit mains supply.
Fuse in mains plug blown.	Replace fuse. A value of 1A is recommended.
Fuse in mains input on back panel blown.	Use 1A for 110 VAC and 500mA for 220 VAC

Reason	Action
System initially turned ON.	Press 'SET' to initialise system
Torque measurement system not working / connected.	Check measurement system is functioning. If no compatible torque measurement system is used, the 25 way to 25 way lead (supplied) will need to be plugged in. Press 'SET' to initialise system
Emergency Stop pressed	Remove hazard. Press 'SET' to initialise system.
Overload protection activated	Refer to OVERLOAD section on page 7. Ensure torque is decreasing.

Reason	Action
Motor lead not connected.	Connect load to back of control box.
Other	Return to Norbar for repair.

Always replace fuses with same value and type.

Manual Release of Torque

If the motor unit has failed with torque on the loader, it is possible to remove the motor and release the torque by hand.

Tools required will be a 3mm hexagonal key and a 13mm hexagonal drive.

Remove 4 socket head cap screws (3mm heads) that hold motor to flange (NOT flange to gearbox).
Remove the motor. Insert a 13mm hexagonal key to drive gearbox input.

**NORBAR TORQUE TOOLS LTD**

Beaumont Road, Banbury,
Oxfordshire, OX16 1XJ
UNITED KINGDOM
Tel + 44 (0)1295 270333
Email enquiry@norbar.com

**NORBAR TORQUE TOOLS PTE LTD**

194 Pandan Loop
#07-20 Pantech Business Hub
SINGAPORE 128383
Tel + 65 6841 1371
Email singapore@norbar.com.au

**NORBAR TORQUE TOOLS PTY LTD**

45-47 Raglan Avenue, Edwardstown,
SA 5039
AUSTRALIA
Tel + 61 (0)8 8292 9777
Email enquiry@norbar.com.au

**NORBAR TORQUE TOOLS (SHANGHAI) LTD**

E Building-5F, no. 1618 Yishan Road,
Minhang District, Shanghai
CHINA 201103
Tel + 86 21 6145 0368
Email sales@norbar.com.cn

**NORBAR TORQUE TOOLS INC**

36400 Biltmore Place, Willoughby,
Ohio, 44094
USA
Tel + 1 866 667 2279
Email inquiry@norbar.us

**NORBAR TORQUE TOOLS INDIA PVT. LTD**

Plot No A-168, Khairne Industrial Area,
Thane Belapur Road, Mahape,
Navi Mumbai – 400 709
INDIA
Tel + 91 22 2778 8480
Email enquiry@norbar.in

**NORBAR TORQUE TOOLS (NZ) LTD**

B3/269A Mt Smart Road
Onehunga, Auckland 1061
NEW ZEALAND
Tel + 64 9579 8653
Email nz@norbar.com.au

www.norbar.com