

LARZEP

HYDRAULIC

Mekanik Kilitli Hidrolik Krikolar

- 30 tondan 1.100 tona kadar kapasiteli onlarca model
- 45 mm den 300 mm ye kadar stroke seçenekleri
- Standart, extra yassı tip ve Alüminyum modeller
- 700 bar çalışma basıncında, yük dönüşlü hidrolik sistem
- Mekanik kilit kapasitesinin %50 daha fazla yüke dayanıklı
- Vidalı piston sayesinde kriko uzun bir süre yük altında kalabilir
- STX, SATM ve STR olmak üzere üç farklı model
- Paslanmaya ve yan yüke karşı extra dayanıklı kaplama
- Oynak başlı kafa STR modellerinde opsiyonel olarak sunulur
- STX modellerinde oynak başlı kafa standart olarak bulunur
- Türkiye'de servis ve yedek parça desteği



STX



SATM



STR



Surkon Makina Sanayi ve Ticaret LTD. ŞTİ.

İvedik Organize Sanayi Bölgesi - Özpetek Sanayi Sitesi 1390 Sokak No: 12 - TR-06378 - Yenimahalle / ANKARA
Tel: +90 (312) 386 14 64 / Faks: +90 (312) 386 14 88 / info@surkon.com / www.surkon.com



ISO 9001: 2008
Kalite Yönetim Sistemi
TS EN ISO / IEC 17021
AB-0049-YS
Sertifika No: 57812

SURKON
INTERNATIONAL

LARZEP

HYDRAULIC

Mekanik Kilitli Hidrolik Krikolar

STX: Pancake serisi. Extra alçak tabanlı modeldir.
50 ton ile 1100 ton arasında yalnızca 45 mm stroke seçeneğlidir.

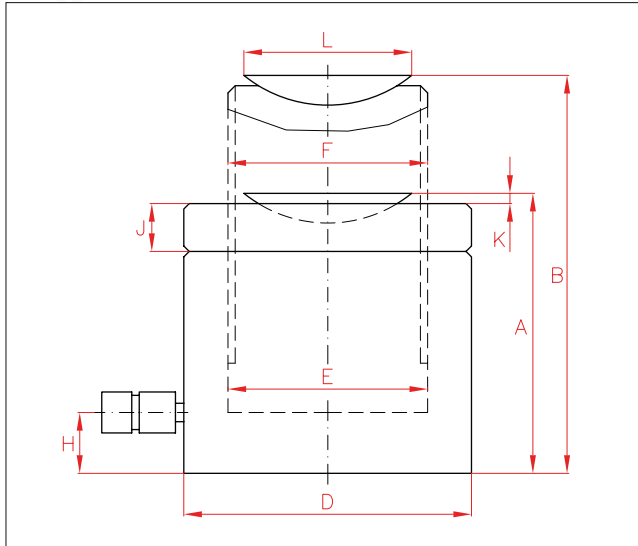

Kapasite		Stroke	Model	Yağ Hac.	A	B	D	E	F	H	J	K	L	Etki	Ağırlık
Tn	kN	mm	LARZEP	cm ³	mm	mm	mm	mm	mm	mm	mm	mm	mm	cm ²	kg
50	486	50	STX05005	355	125	175	120	95	Tr 95x4	19	21	6	92	71	11
90	911	45	STX09004	597	137	182	165	130	Tr 130x6	21	31	8	126	133	22
140	1.380	45	STX14004	905	148	193	200	160	Tr 160x6	27	38	9	148	201	39
220	2.156	45	STX22004	1.413	155	200	255	200	Tr 200x6	28	40	10	157	314	62
350	3.468	45	STX35004	2.208	178	223	310	250	Tr 250x6	35	50	11	240	491	111
430	4.227	45	STX43004	2.771	184	229	340	280	Tr 280x6	35	55	10	260	616	126
550	5.520	45	STX56004	3.618	192	237	390	320	Tr 320x6	38	60	10	295	804	193
670	6.600	45	STX67004	4.330	236	281	430	350	Tr 350x6	50	75	15	295	962	259
880	8.620	45	STX88004	5.655	268	313	490	400	Tr 400x6	60	85	20	325	1.257	482
1.100	10.905	45	STX110004	7.157	295	340	550	450	Tr 450x6	65	95	25	400	1.590	532

Surkon Makina Sanayi ve Ticaret LTD. ŞTİ.

İvedik Organize Sanayi Bölgesi - Özpetek Sanayi Sitesi 1390 Sokak No: 12 - TR-06378 - Yenimahalle / ANKARA
Tel: +90 (312) 386 14 64 / Faks: +90 (312) 386 14 88 / info@surkon.com / www.surkon.com



ISO 9001:2008
Kalite Yönetim Sistemi
TS EN ISO / IEC 17021
AB-0049-YS
Sertifika No: 57812

SURKON
INTERNATIONAL

LARZEP

HYDRAULIC

Mekanik Kilitli Hidrolik Krikolar

SATM: Alüminyum serisi.

Bu seri 30 ton ile 200 ton arasında

300 mm stroka kadar alüminyum krikoları içerir.

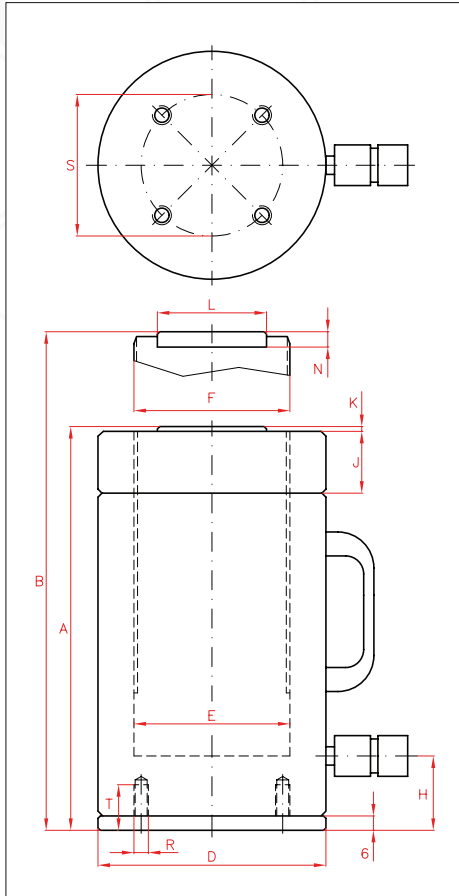

Kapasite		Stroke	Model	Yağ Kap.	A	B	D	E	F	H	J	K	L	N	R	S	T	Etki	Ağırlık
Tn	kN	mm	LARZEP	cm ³	mm	mm	mm	mm	mm	mm	mm	mm	mm	mm	mm	mm	mm	cm ²	kg
30	303	50	SAT03005	221	173	223	105	75	Tr 75x4	24	25	3	45	11	M6	85	19	44	4,4
		100	SAT03010	442	223	323	105	75	Tr 75x4	24	25	3	45	11	M6	85	19	44	5,6
		150	SAT03015	663	273	423	105	75	Tr 75x4	24	25	3	45	11	M6	85	19	44	6,8
		200	SAT03020	884	333	533	105	75	Tr 75x4	24	25	3	45	11	M6	85	19	44	8,0
		250	SAT03025	1.104	383	633	105	75	Tr 75x4	24	25	3	45	11	M6	85	19	44	9,2
		300	SAT03030	1.325	433	733	105	75	Tr 75x4	24	25	3	45	11	M6	85	19	44	10,5
50	487	50	SAT05005	354	193	243	135	95	Tr 95x4	26	35	3	61	12	M6	115	19	71	7,9
		100	SAT05010	709	243	343	135	95	Tr 95x4	26	35	3	61	12	M6	115	19	71	9,9
		150	SAT05015	1.063	293	443	135	95	Tr 95x4	26	35	3	61	12	M6	115	19	71	11,9
		200	SAT05020	1.418	353	553	135	95	Tr 95x4	26	35	3	61	12	M6	115	19	71	13,9
		250	SAT05025	1.772	403	653	135	95	Tr 95x4	26	35	3	61	12	M6	115	19	71	15,9
		300	SAT05030	2.126	453	753	135	95	Tr 95x4	26	35	3	61	12	M6	115	19	71	17,9
100	911	50	SAT10005	664	216	266	180	130	Tr 130x6	32	42	3	88	14	M6	160	19	133	15,6
		100	SAT10010	1.327	266	366	180	130	Tr 130x6	32	42	3	88	14	M6	160	19	133	19,2
		150	SAT10015	1.991	326	476	180	130	Tr 130x6	32	42	3	88	14	M6	160	19	133	22,8
		200	SAT10020	2.655	376	576	180	130	Tr 130x6	32	42	3	88	14	M6	160	19	133	26,4
		250	SAT10025	3.318	446	696	180	130	Tr 130x6	32	42	3	88	14	M6	160	19	133	29,9
		300	SAT10030	3.982	496	796	180	130	Tr 130x6	32	42	3	88	14	M6	160	19	133	33,5
140	1.380	50	SAT14005	1.005	234	284	225	160	Tr 160x6	43	50	3	88	14	M6	200	19	201	26,0
		100	SAT14010	2.011	284	384	225	160	Tr 160x6	43	50	3	88	14	M6	200	19	201	31,6
		150	SAT14015	3.016	345	495	225	160	Tr 160x6	43	50	3	88	14	M6	200	19	201	37,2
		200	SAT14020	4.021	395	595	225	160	Tr 160x6	43	50	3	88	14	M6	200	19	201	43,1
		250	SAT14025	5.027	465	715	225	160	Tr 160x6	43	50	3	88	14	M6	200	19	201	48,3
		300	SAT14030	6.032	515	815	225	160	Tr 160x6	43	50	3	88	14	M6	200	19	201	53,9
200	1.946	50	SAT20005	1.418	249	299	265	190	Tr 190x6	43	60	3	111	15	M6	225	19	284	42,9
		100	SAT20010	2.835	299	399	265	190	Tr 190x6	43	60	3	111	15	M6	225	19	284	50,6
		150	SAT20015	4.253	364	514	265	190	Tr 190x6	43	60	3	111	15	M6	225	19	284	58,4
		200	SAT20020	5.671	414	614	265	190	Tr 190x6	43	60	3	111	15	M6	225	19	284	66,1
		250	SAT20025	7.088	479	729	265	190	Tr 190x6	43	60	3	111	15	M6	225	19	284	73,9
		300	SAT20030	8.506	529	829	265	190	Tr 190x6	43	60	3	111	15	M6	225	19	284	81,6

Surkon Makina Sanayi ve Ticaret LTD. ŞTİ.

İvedik Organize Sanayi Bölgesi - Özpetek Sanayi Sitesi 1390 Sokak No: 12 - TR-06378 - Yenimahalle / ANKARA

Tel: +90 (312) 386 14 64 / Faks: +90 (312) 386 14 88 / info@surkon.com / www.surkon.com



ISO 9001: 2008
Kalite Yönetim Sistemi
TS EN ISO / IEC 17021
AB-0069-YS
Sertifika No: 57812

SURKON
INTERNATIONAL

LARZEP

HYDRAULIC

Mekanik Kilitli Hidrolik Krikolar

STR: Standart seri.
30 ton ile 1100 ton arasında,
45 mm den 300 mm kadar
stroke boylu seçenekler mevcuttur.

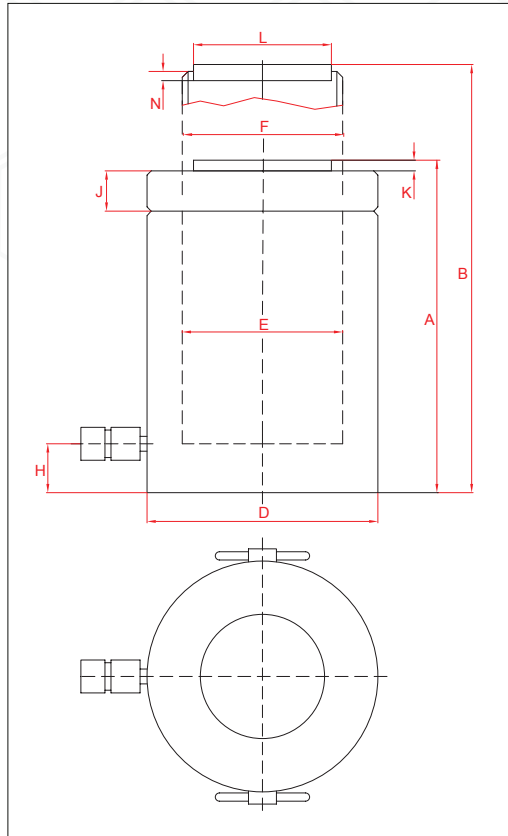

Kapasite		Etki cm ²	D mm	E mm	F mm	H mm	J mm	K mm	L mm	N mm
Tn	kN									
30	303	44	100	75	Tr 75x4	25	30	3	45,5	8
50	487	71	125	95	Tr 95x4	30	36	3	61,5	9
100	911	133	180	130	Tr 130x6	30	44	3	88	11
140	1.380	201	215	160	Tr 160x6	39	46	3	111	12
200	2.156	314	265	200	Tr 200x6	50	50	3	131	12
350	3.369	491	330	250	Tr 250x6	59	60	3	178	20
430	4.227	616	380	280	Tr 280x6	75	75	5	200	22
560	5.520	804	430	320	Tr 320x6	80	80	5	250	30
670	6.605	962	475	350	Tr 350x6	90	90	5	290	40
880	8.625	1.256	540	400	Tr 400x6	100	100	5	290	40
1.100	10.916	1.590	600	450	Tr 450x6	110	113	5	325	50

Kapasite	Stroke	Model	Yağ Kap.	A	Ağırlık
Tn	mm	LARZEP	cm ³	mm	Kg
30	50	ST03005	221	169	10,3
	100	ST03010	442	219	13,2
	150	ST03015	663	269	17,2
	200	ST03020	884	319	19,2
50	300	ST03030	1.325	419	25,9
	50	ST05005	355	185	17,3
	100	ST05010	709	235	22
	150	ST05015	1.063	285	29,5
100	200	ST05020	1.417	335	31,8
	300	ST05030	2.126	435	40,9
	50	ST10005	663	200	40
	100	ST10010	1.327	250	48,2
140	150	ST10015	1.989	300	58,5
	200	ST10020	2.654	350	68,5
	300	ST10030	3.980	450	83,5
	50	ST14005	1.005	211	60
200	100	ST14010	2.010	259	72,5
	150	ST14015	3.014	309	88
	200	ST14020	4.020	359	102
	300	ST14030	6.029	459	130
350	50	ST20005	1.570	245	105
	100	ST20010	3.140	295	128
	150	ST20015	4.710	345	149
	250	ST20025	7.850	395	213
430	50	ST35005	2.453	275	183
	100	ST35010	4.906	345	229
	150	ST35015	7.360	395	263
	250	ST35025	12.265	495	329
560	50	ST43005	3.079	335	296
	100	ST43010	6.157	385	340
	150	ST43015	9.236	435	385
	250	ST43025	15.393	535	473
670	50	ST56005	4.019	345	390
	100	ST56010	8.038	425	481
	150	ST56015	12.058	475	537
	250	ST56025	20.095	575	650
880	50	ST67005	4.811	395	545
	100	ST67010	9.621	445	614
	150	ST67015	14.432	495	683
	250	ST67025	24.053	595	821
1.100	50	ST88005	6.280	400	714
	100	ST88010	12.560	505	901
	150	ST88015	18.840	555	1.008
	250	ST88025	31.400	655	1.170
1.100	50	ST110005	7.949	443	969
	100	ST110010	15.896	548	1.201
	150	ST110015	23.845	598	1.310
	250	ST110025	39.741	698	1.530

Surkon Makina Sanayi ve Ticaret LTD. ŞTİ.

İvedik Organize Sanayi Bölgesi - Özpetek Sanayi Sitesi 1390 Sokak No: 12 - TR-06378 - Yenimahalle / ANKARA
Tel: +90 (312) 386 14 64 / Faks: +90 (312) 386 14 88 / info@surkon.com / www.surkon.com



ISO 9001: 2008
Kalite Yönetim Sistemi
TS EN ISO / IEC 17021
AB-0069-YS
Sertifika No: 57812

SURKON
INTERNATIONAL