

Parts List and

Operating Instructions for:

	PH63C
	PH83C
PH6	PH113C
PH8	PH303C
PH11	HST11
PH30	HST11S

HYDRA-GRIP-O-MATIC® PULLER AND STRAIGHTENER TOOL

Max. Capacity: 6 Ton (PH6 & PH63C); 8 Ton (PH8 & PH83C); 15 Ton (PH11, PH113C, & HST11);
30 Ton (PH30 & PH303C)

NOTE:

- These instructions must be read and carefully followed.
- Carefully inspect the puller and/or straightener tool upon arrival. The carrier, not the manufacturer, is responsible for any damage resulting from shipment.



SAFETY PRECAUTIONS

WARNING: To help prevent personal injury,

- These pullers and the straightener tool should be used only by trained personnel familiar with them.
- Safety glasses must be worn at all times by the operator and anyone within sight of the puller and straightener tool.
- Select the proper size and capacity of puller for the job.
- Align the puller on the same centerline as the part being removed. Failure to align parts correctly can result in a dangerous operating situation because of the high hydraulic pressures used.
- Wrap the work in a Power Team protective blanket before applying pressure to provide protection from injury caused by flying parts should a part ever break.
- Always apply force gradually.

IMPORTANT: DO NOT USE HEAT, HAMMERS, OR IMPACT TOOLS ON THESE PULLERS.
THIS WILL CAUSE DAMAGE THAT VOIDS THE PULLER WARRANTY.

PULLER SETUP AND OPERATION

NOTE: These pullers have a 2/3-way combination puller

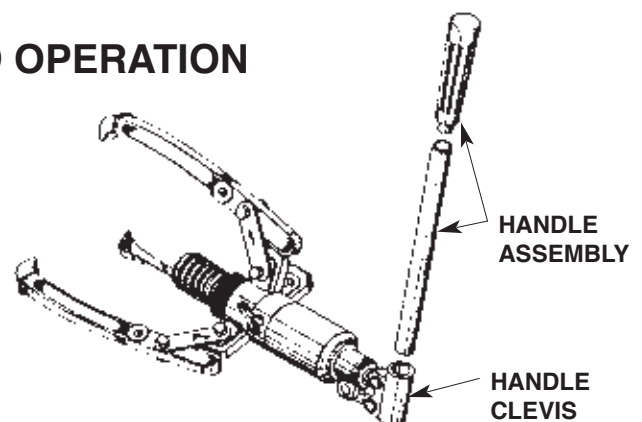

Figure 1

PULLER SETUP AND OPERATION (CONTINUED)

3. Turn the control valve knob completely in a clockwise direction to advance the piston. See Figure 2.

IMPORTANT: Position the control valve knob so it does not contact the puller head and can be turned freely.



CONTROL VALVE KNOB

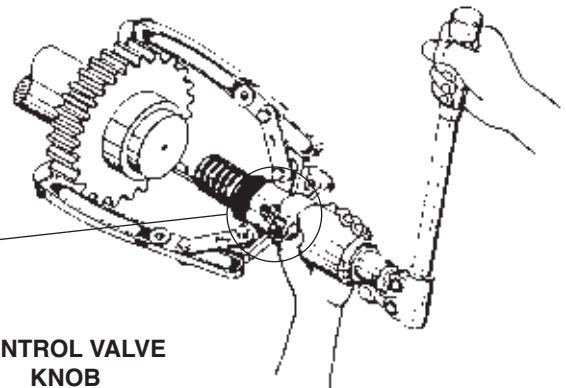

Figure 2

4. Begin positioning the puller and puller jaws around the part to be pulled, removing most of the slack by threading the adjusting locknut further onto the puller body or adjusting the puller straps on the jaws. Pump the handle to advance the piston, stopping just as the removable cone reaches the part. Make final puller positioning adjustments with the adjusting locknut or the piston. The puller must be on the same centerline as the part to be pulled and the jaws fully engaged and secure. See Figure 3.



WARNING: The adjusting locknut must be fully engaged with the threads of the puller body as shown below on all 6, 8, & 15 Ton pullers. On 30 ton puller, full thread engagement minimum crosshead required.

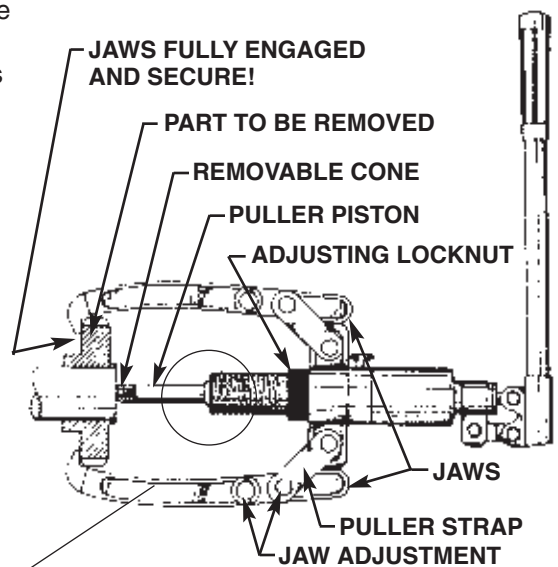
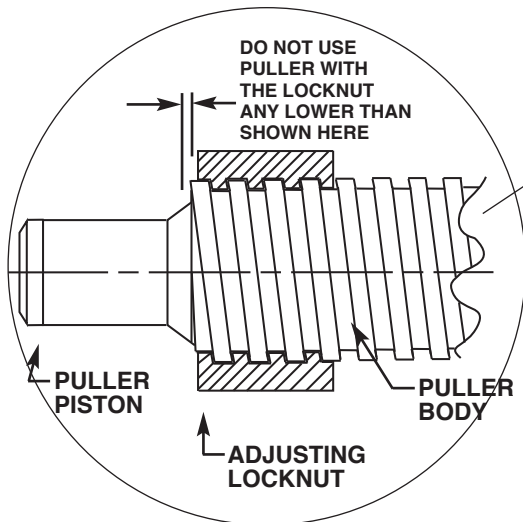

Figure 3



5. The handle assembly rotates a full 360° to allow the best handle location for the job. See Figure 4.

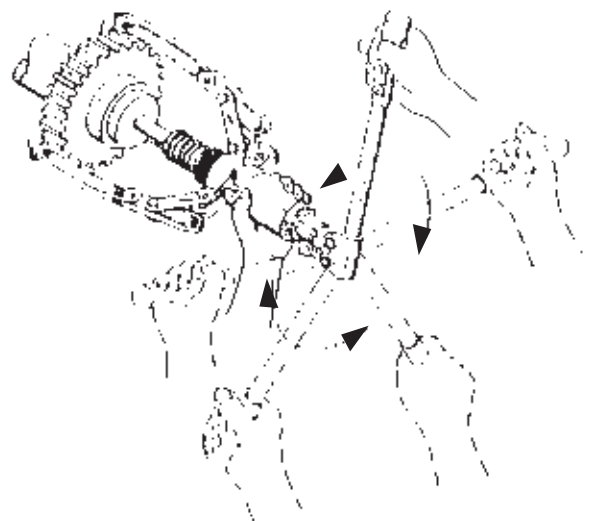

Figure 4

PULLER SETUP AND OPERATION (CONTINUED)

6. Hold the puller with one hand and pump the handle with your other hand, advancing the piston until the part is removed. See Figures 5 & 6.

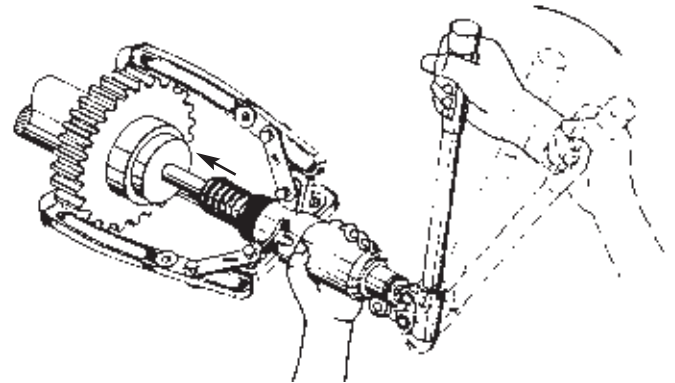

Figure 5

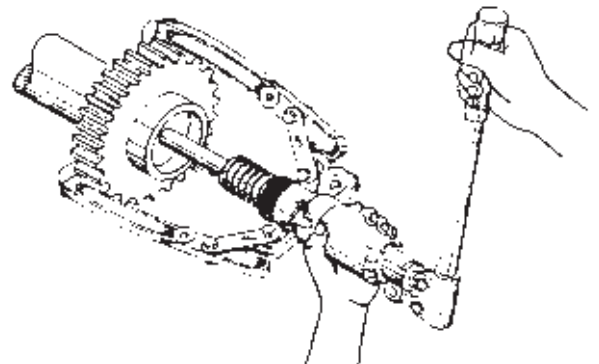

Figure 6

7. Turn the control valve knob completely in a counterclockwise direction to retract the piston. See Figure 7.

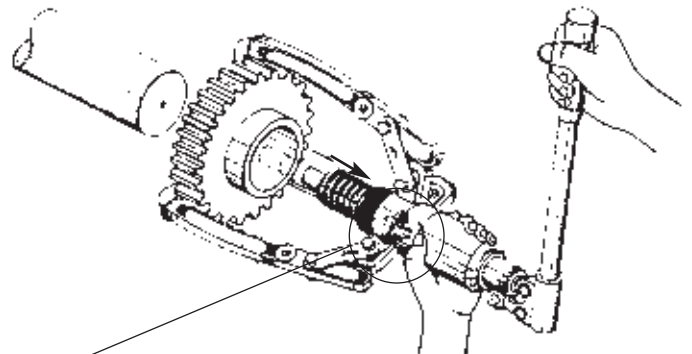
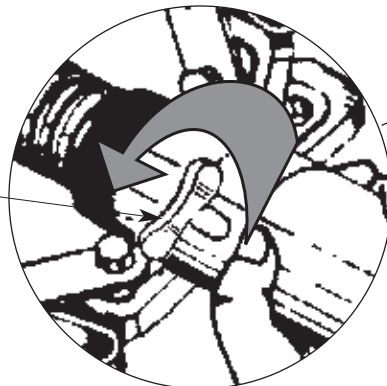

Figure 7

CONTROL VALVE
KNOB



Item No.	Part No. (For PH63C)	Part No. (For PH83C)	Part No. (For PH113C)	No. Req'd	Description
1	252926	252926	252926	1	Handle Clevis
2	252933	252933	252933	1	Clevis Pin - Long
3	252936	252936	252936	1	Handle Lever
4	252941	252941	252941	1	Retainer Nut
6	252914	252914	252914	1	Pump Housing and Piston Rod Assembly
7	252912	252912	252912	1	Swivel Clevis
8	252913	252913	252913	1	Inlet/Outlet Valve Assembly
9	252908	252909	252910	1	Bladder Housing
10	252911	252911	252911	1	Bladder Housing Retainer Nut
11	252903	252904	252904	1	Control Valve Knob
12	252902	252902	252902	1	O-ring
13	252925	252925	252925	1	Link Connector
14	252932	252932	252932	3	Retaining Ring
15	252887	252887	252887	1	Compression Ring - Small
16	252905	252906	252907	1	Reservoir Bladder
17	252888	252889	252890	1	Compression Ring - Large
18	252900	252900	252900	1	Oil Fill Screw Assembly
19	252894	252895	252896	1	Hydraulic Puller Body
20	252901	252916	252916	1	Steel Ball
21	252937	252938	252939	1	U-cup
22	252940	252940	252940	1	O-ring
23	252891	252892	252893	1	Puller Piston Rod
24	252917	252918	252919	1	Puller Crosshead
25	252882	252883	252884	1	Cylinder Retaining Nut
26	252934	252934	252935	1	Rod Wiper
27	252885	252886	252886	1	Compression Spring
28	252929	252929	252931	1	Removable Cone Assembly
29	252923	252924	252924	6	Puller Strap
30	252920	252921	252922	3	Puller Jaw
		*30902	*30902	3	Long Puller Jaw (Optional)
31	252927	252928	252928	6	Puller Jaw Screw and Nut
32	252897	252898	252899	1	Adjusting Locknut
33	252957	252957	252957	1	Handle Grip Assembly
34	---	---	---	1	See Note Below
35	252951	252951	252951	2	Clevis Pin - Short
36	PH6	PH8	PH11	1	Replacement Hydraulic Assembly Complete w/ Handle

PARTS INCLUDED BUT NOT SHOWN

351491	351492	351493	1	Trade Name Decal
252948	252949	252950	1	Plastic Case

*To order a set of three long jaws, order No. 1188.

NOTE: Relief Valve Assembly (Item #34) must not be serviced except by a qualified hydraulic service center. Contact your nearest service center or Power Team Technical Services for further information.

PREVENTIVE MAINTENANCE

- Keep the puller as clean as possible to help prevent contamination from entering the hydraulic system and to prevent rust.
- If additional oil is needed, use Power Team hydraulic oil or a comparable jack oil.

- Reservoir oil capacity:

PH6 & PH63C = .19 pt (90 cc)	PH11 & PH113C = .32 pt (150 cc)
PH8 & PH83C = .25 pt (120 cc)	

- Periodically lubricate puller pivot points.
- Store the puller and all accessories in its plastic case.

PULLER PARTS LIST-PH303C

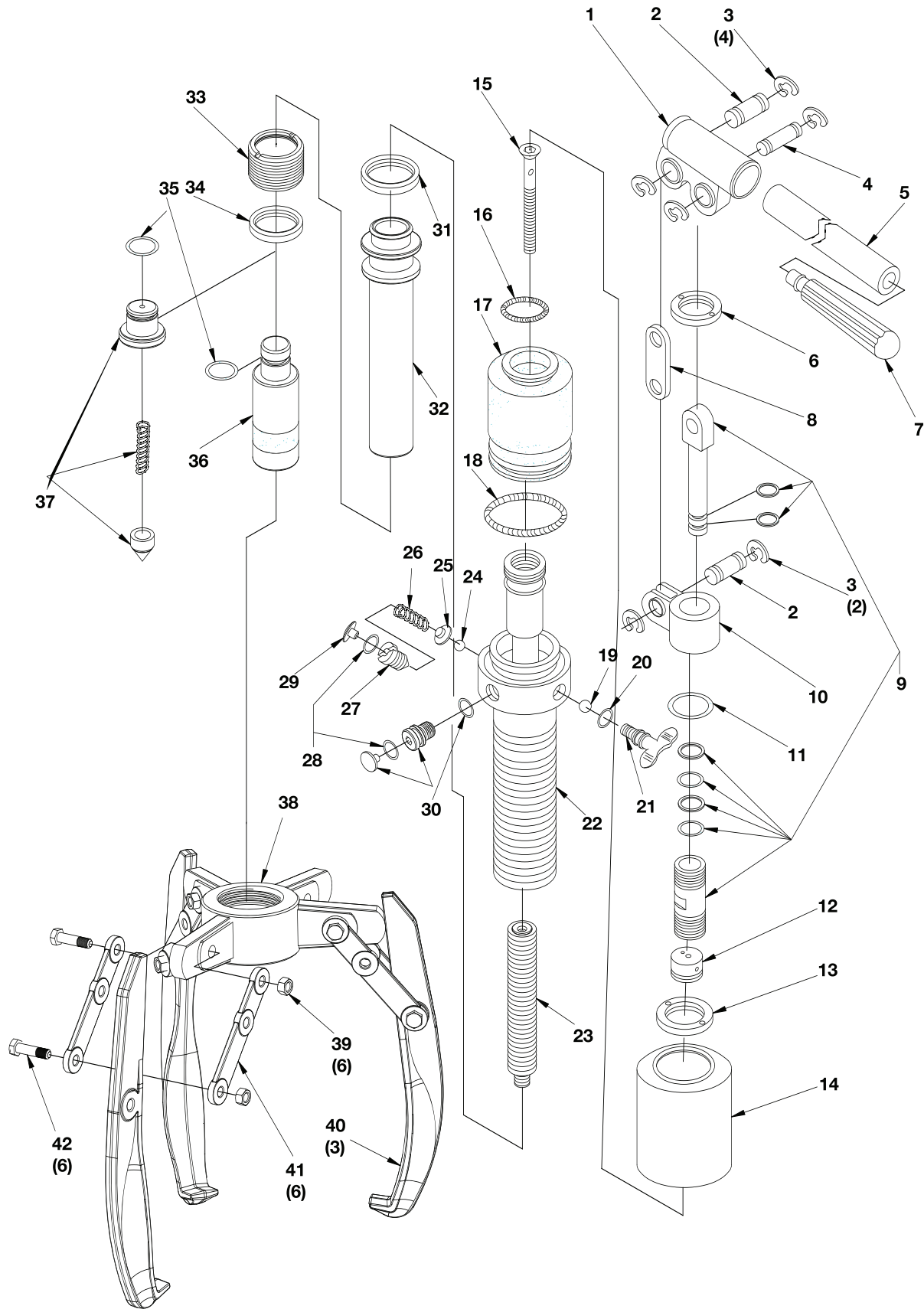

PH303C PULLER, HYD. GEAR 30 TON, W CASE & BLANKET

ITEM	SPX NO.	QTY P/N	DESCRIPTION
1	252926	1	Clevis, Handle
2	2000616	2	Pin, Clevis - Short
3	252932	6	Ring, Retaining
4	2000620	1	Pin, Clevis - Long
5	252936	1	Lever, Handle
6	252941	1	Nut, Retainer (Nut, Cylinder Retaining)
7	252957	1	Assembly, Handle Grip
8	252925	1	Link, Connector
9	252914	1	Assembly, Pump Housing Pump and Piston
10	252912	1	Clevis, Swivel
11	252940	1	O-ring
12	252913	1	Assembly, Inlet / Outlet Valve
13	2000599	1	Nut, Retainer Housing Bladder
14	2000598	1	Housing, Bladder
15	2000621	1	Screw, Drag Spring
16	252887	1	Ring, Compression - Small (Spring)
17	2000601	1	Bladder, Reservoir
18	2000602	1	Ring, Compression - Large (Spring)
19	252916	1	Ball, Steel .250"
20	252902	1	O-ring
21	2000600	1	Knob, Valve Control
22	2000603	1	Body, Hydraulic Puller
23	2000622	1	Spring, Drag
24		1	
25		1	
26		1	
27		1	
28		2	
29		1	
30	2000629	1	Screw, Ass'y Oil Fill
31	2000604	1	U-cup
32	2000605	1	Rod, Piston Puller
33	2000607	1	Nut, Cylinder Retaining
34	2000608	1	Wiper, Rod Nitrile
35	2000630	2	O-ring
36	2000631	1	Adapter
37	2000632	1	Cone Assembly, Removable
38	2000606	1	Crosshead, Puller
39	2000614	6	Nut, Puller Jaw
40	2000612	3	Jaw, Puller
41	2000611	6	Strap, Puller
42	2000609	6	Screw, Puller Jaw
43			
44	2000613	3	Jaw, Long Puller (Optional, Not Shown)
45	2000617	1	Case, Metal Storage
46	2000618	1	Blanket, Protective
47	1000199	1	Decal
48	PH30	1	Pump, Replacement Assembly

NOTE: Relief Valve Assembly (Item #24–#29) must not be serviced except by a qualified hydraulic service center. Contact your nearest service center or Power Team Technical Services for further information.

PREVENTIVE MAINTENANCE

- Keep the puller as clean as possible to help prevent contamination from entering the hydraulic system and to prevent rust.
- If additional oil is needed, use Power Team hydraulic oil or a comparable jack oil.

• Reservoir oil capacity:

PH30 & PH303C = .68 pt (320 cc)

- Periodically lubricate puller pivot points.
- Store the puller and all accessories in its plastic case.

STRAIGHTENER TOOL SETUP AND OPERATION

1. Thread the straightener tool onto the puller body. See Figure 8.

WARNING: The straightener tool must be fully engaged with the threads of the puller body as shown below.

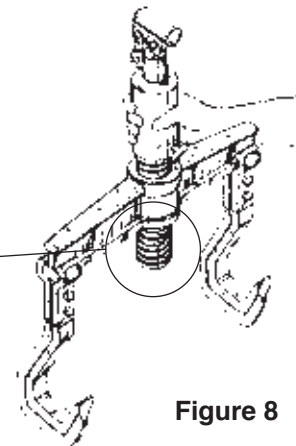
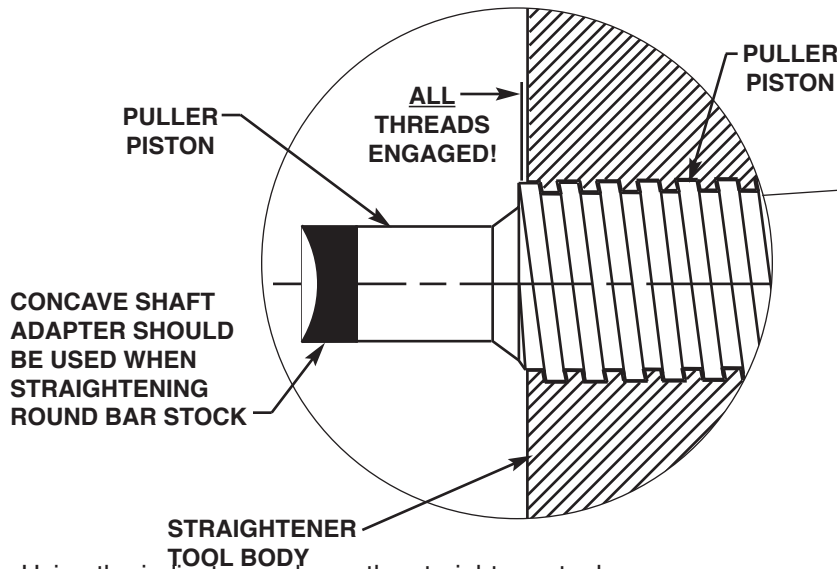

2. Using the indicator marks on the straightener tool body, position the straightener tool arms an equal distance apart from the center of the puller body. See Figure 9.

WARNING: Failure to equally position the straightener tool arms on the straightener body creates a very dangerous situation. The force will be unevenly distributed to each arm causing tool breakage and personal injury.

IMPORTANT: DO NOT USE HEAT, HAMMERS, OR IMPACT TOOLS ON THESE PULLERS. THIS WILL CAUSE DAMAGE THAT VOIDS THE PULLER WARRANTY.

3. Place the handle assembly into the handle clevis. See Figure 9.
4. Place puller and tool on a bar or round bar stock to be straightened. Turn the control valve knob completely in a clockwise direction to advance the piston. See Figure 9.

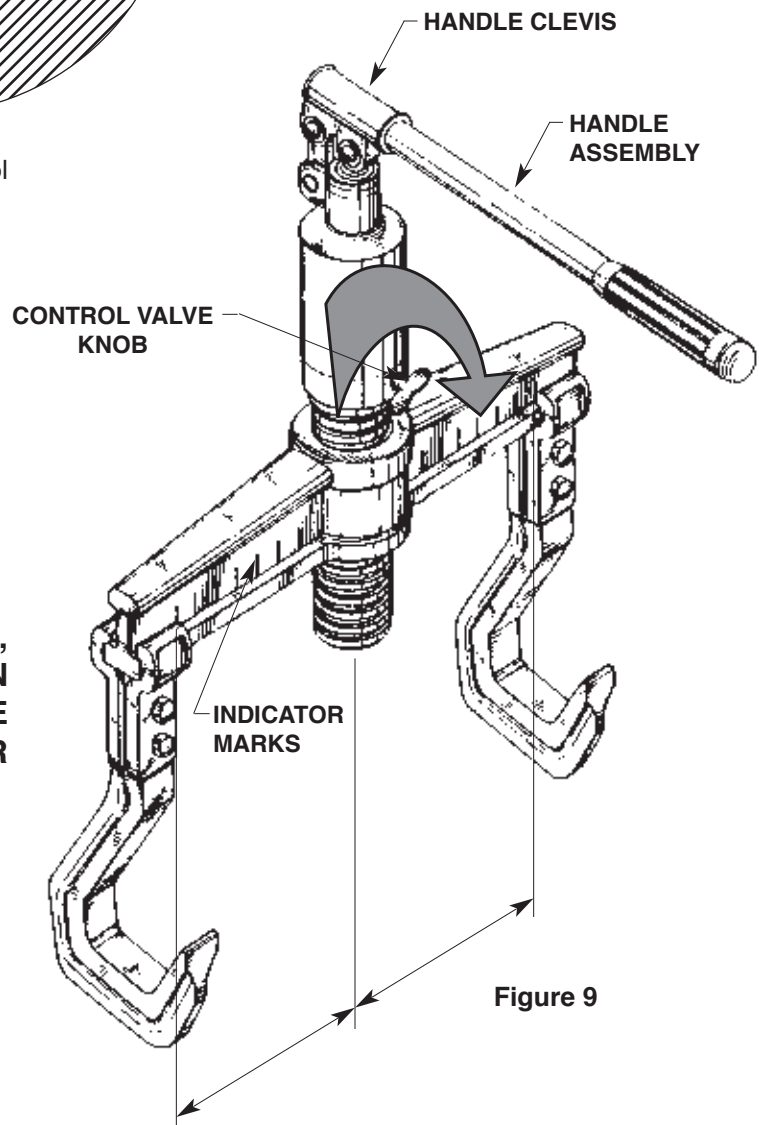

STRAIGHTENER TOOL SETUP AND OPERATION (CONTINUED)

5. Advance the piston by pumping on the handle until the bar or round bar stock is straight. See Figure 10.
6. Turn the control valve knob completely in a counterclockwise direction to retract the piston. See Figure 10.

CONCAVE
SHAFT ADAPTER

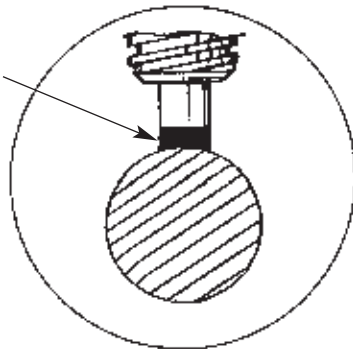

CONTROL VALVE
KNOB

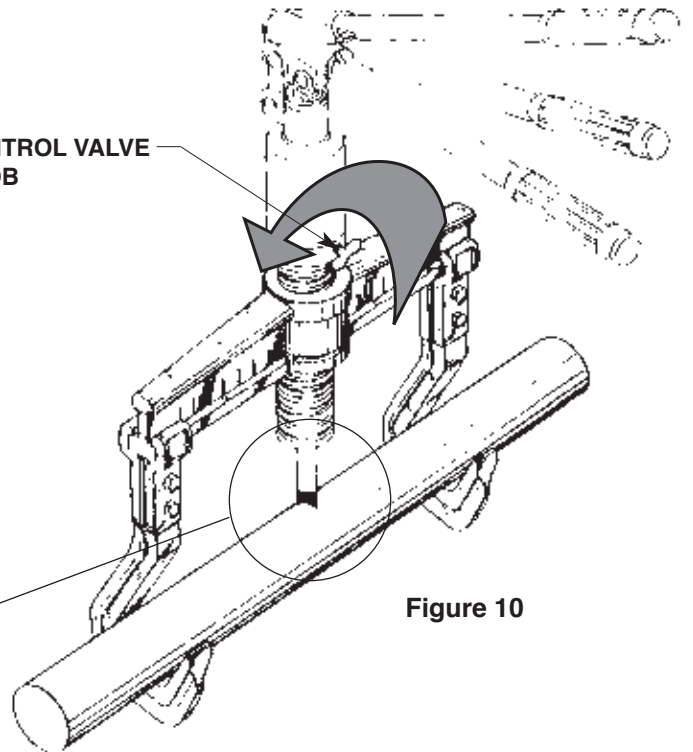
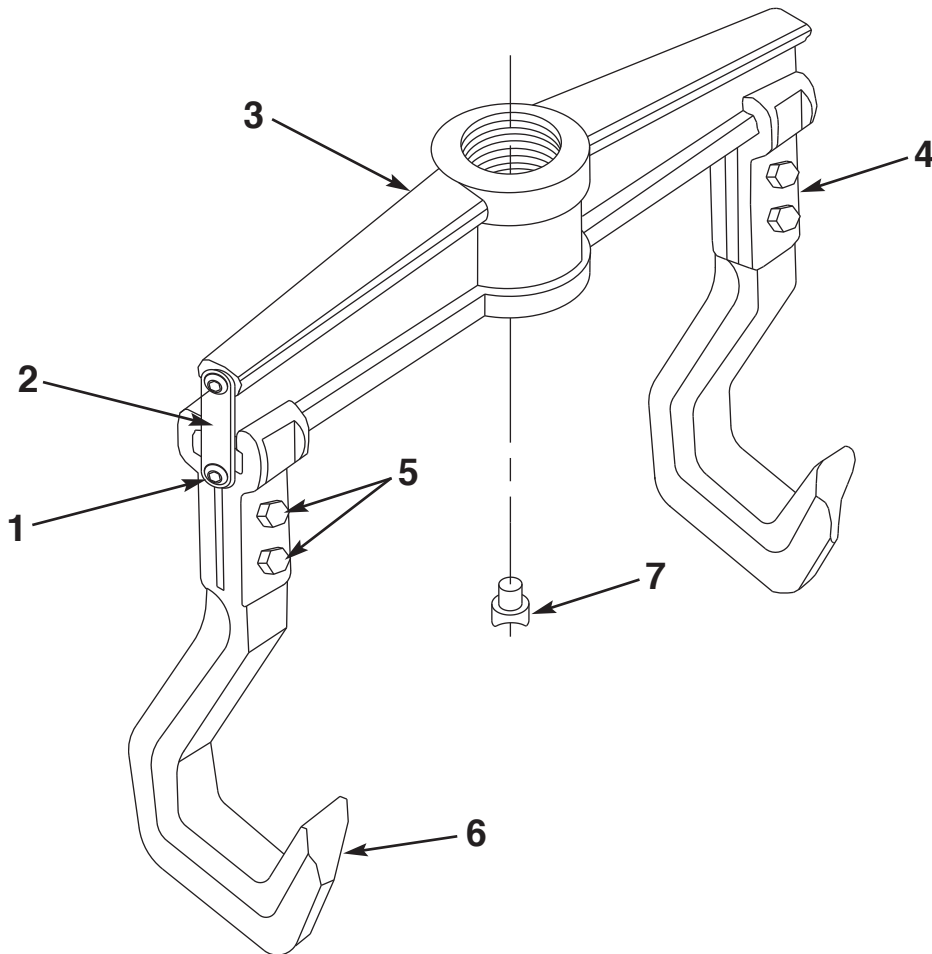

Figure 10

HST11 STRAIGHTENER TOOL PARTS LIST



Item No.	Part No.	No. Req'd	Description
1	253042	4	Screw
2	253041	2	Strap
3	253037	1	Crossbar
4	253038	2	Jaw Holder
5	253040	4	Nut and Bolt Assembly
6	253039	2	Jaw
7	253060	1	Concave Ram Cap (Assemble to piston rod of puller.)

PARTS INCLUDED BUT NOT SHOWN

222142	1	Warning Decal
351563	1	Trade Name Decal
PH11	1	Hydraulic Puller Assembly Complete (With handle, also see back sheet 2 of 4 and 3 of 4)

NOTE: HST11S is a set consisting of HST11 straightener tool and PH11 hydraulic puller with handle.

Lista de piezas e
instrucciones de funcionamiento de:

PH63C	
PH83C	HST11S
PH113C	PH6
PH303C	PH8
HST11	PH11

EXTRACTOR HIDRÁULICO HYDRA-GRIP-O-MATIC® Y HERRAMIENTA ENDEREZADORA

Capacidad máxima: 6 toneladas (PH6 y PH63C); 8 toneladas (PH8 y PH83C); 11 toneladas (PH11, PH113C, HST11 y HST11S), 30 toneladas (PH30 & PH303C)

NOTA:

- Lea y siga estrictamente estas instrucciones.
- Inspeccione cuidadosamente el extractor y/o la herramienta enderezadora cuando la reciba. El transportista, no el fabricante, es el responsable de cualquier daño producido durante el transporte.



PRECAUCIONES DE SEGURIDAD

ADVERTENCIA: Instrucciones para evitar lesiones personales:

- El uso de estos extractores y herramientas enderezadoras sólo debe confiarse a personal capacitado y familiarizado con ellas.
- El operario y cualquier otra persona que se encuentre en las proximidades del extractor y de la herramienta enderezadora debe utilizar gafas protectoras en todo momento.
- Seleccione el extractor de tamaño y capacidad adecuados para el trabajo que vaya a realizar.
- Alinee el extractor con la línea central de la pieza que vaya a retirar. Si no alinea las piezas correctamente, puede producirse una situación peligrosa a causa de las altas presiones hidráulicas utilizadas.
- Envuelva siempre las piezas en una manta protectora de Power Team antes de aplicar presión, a fin de protegerse de posibles lesiones provocadas por los fragmentos que podrían salir despedidos si se rompiera alguna pieza.
- Aplique siempre la fuerza de forma gradual.

IMPORTANTE: NO UTILICE CALOR, MARTILLOS NI HERRAMIENTAS DE IMPACTO EN LOS EXTRACTORES. PROVOCARÁ DAÑOS QUE ANULAN LA GARANTÍA DEL EXTRACTOR.

INSTALACIÓN Y FUNCIONAMIENTO DEL EXTRACTOR

NOTA: Estos extractores tienen un cabezal con una combinación de 2 o 3 vías. La combinación de 3 mordazas es la más recomendable siempre que haya suficiente espacio para su instalación. Tres mordazas ofrecen un agarre más seguro e incluso una mayor fuerza de tracción.

1. Seleccione el extractor de tamaño y capacidad necesarios para el trabajo. Estas dimensiones se definen midiendo el "alcance" y la "extensión" de la pieza que va a extraerse.
2. Coloque el conjunto de la manivela en la abrazadera. Consulte la figura 1.

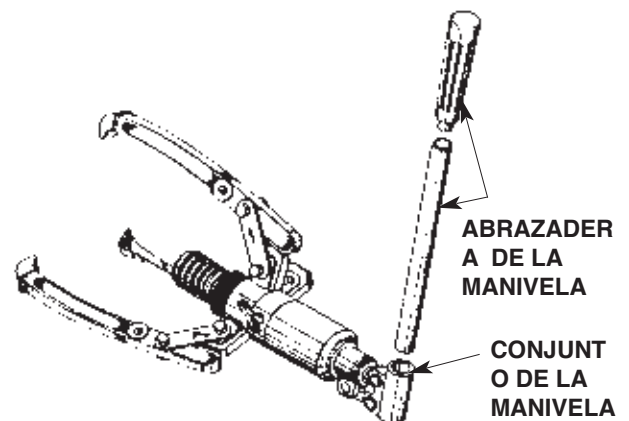

Figure 1

INSTALACIÓN Y FUNCIONAMIENTO DEL EXTRACTOR (CONTINUACIÓN)

3. Gire completamente la perilla de la válvula de control en el sentido de las agujas del reloj para avanzar el pistón. Consulte la figura 2.

IMPORTANTE: Coloque la perilla de la válvula de control de manera que no entre en contacto con el cabezal del extractor y pueda girar libremente.



PERILLA DE LA VÁLVULA DE CONTROL



Figura 2

4. Empiece a colocar el extractor y las mordazas del extractor alrededor de la pieza que va a extraer, eliminando la mayor parte de las holguras a base de ir roscando la tuerca de fijación hacia el cuerpo del extractor o ajustando las articulaciones a las mordazas. Bombeo con la manivela para hacer avanzar el pistón y deténgase justo cuando el cono extraíble llegue a la pieza. Realice los ajustes finales apretando la tuerca de fijación o el pistón. El extractor debe estar alineado con la línea central de la pieza que se va a extraer, y las mordazas completamente acopladas y en posición segura. Consulte la figura 3.



ADVERTENCIA: La tuerca de fijación debe estar completamente acoplada a la rosca del cuerpo del extractor, tal y como se muestra a continuación.

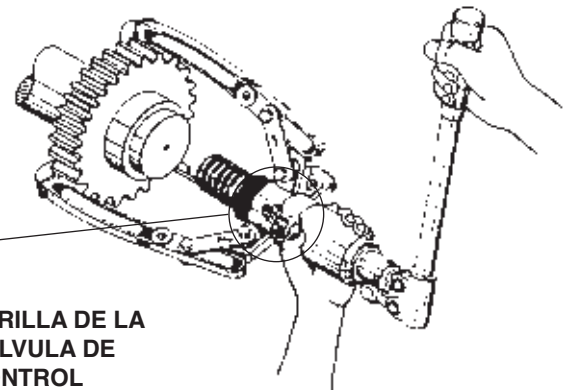

Figura 3



Figura 4

5. El conjunto de la manivela tiene una capacidad de rotación de 360°, lo que permite una óptima colocación de la misma en cada trabajo. Consulte la figura 4.

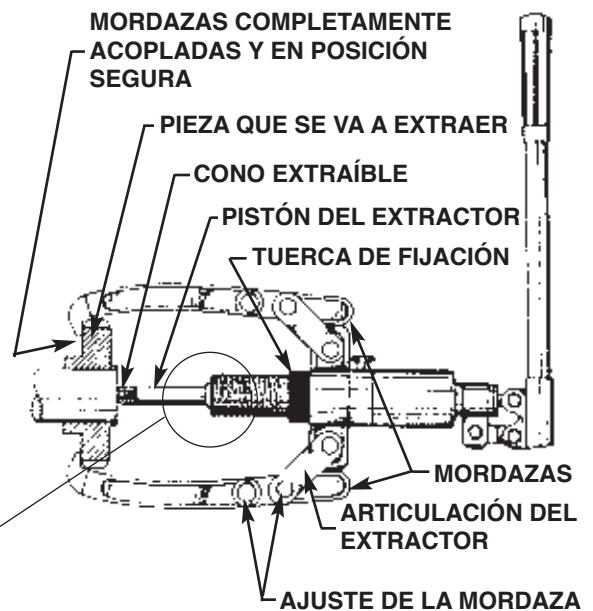
INSTALACIÓN Y FUNCIONAMIENTO DEL EXTRACTOR (CONTINUACIÓN)

6. Sujete el extractor con una mano y con la otra bombee con la manivela haciendo avanzar el pistón hasta extraer la pieza. Consulte las figuras 5 y 6. e piston until the

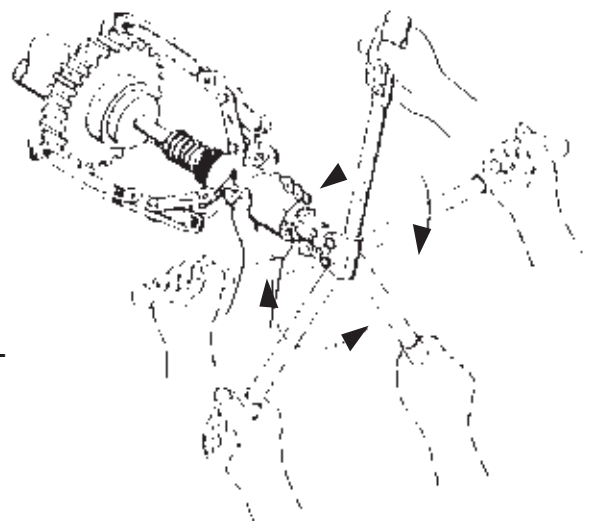
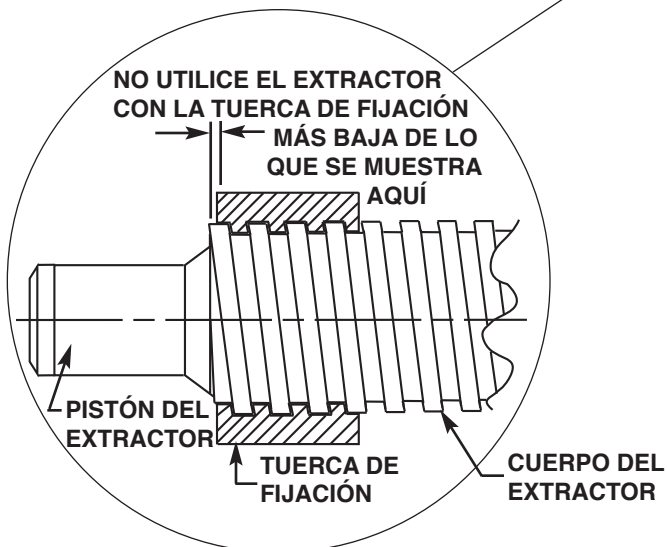

Figura 5

7. Gire completamente la perilla de la válvula de control en el sentido contrario al de las agujas del reloj para hacer retroceder el pistón. Consulte la figura 7.

MANTENIMIENTO PREVENTIVO

- Mantenga el extractor tan limpio como le sea posible para evitar que el sistema hidráulico resulte contaminado por materias extrañas y se oxide.
- En caso de que fuera necesario rellenar el nivel, utilice aceite hidráulico Power Team o un aceite de gato comparable.

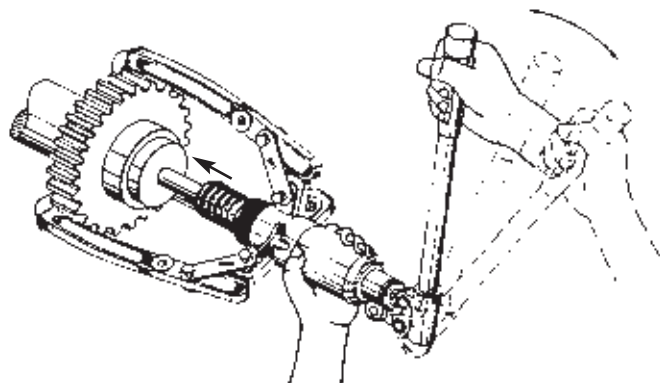
Capacidad del depósito de aceite:

PH6 y PH63C = 0,19 pt (90 cc)

PH8 y PH83C = 0,25 pt (120 cc)

PH11 y PH113C = 0,32 pt (150 cc)

- Lubrique periódicamente los puntos pivotantes del extractor.
- Guarde el extractor y los accesorios en el maletín de plástico.



Figura 6



Figura 7

PERILLA DE LA
VÁLVULA DE
CONTROL

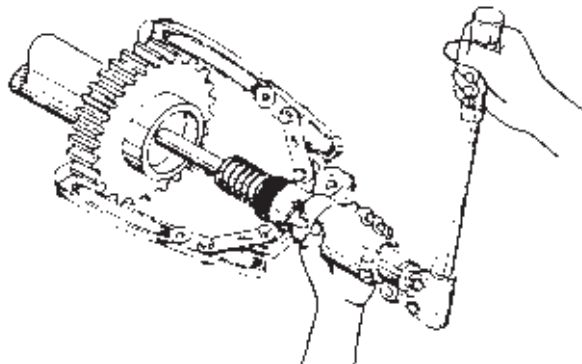

LISTA DE PIEZAS DEL EXTRACTOR

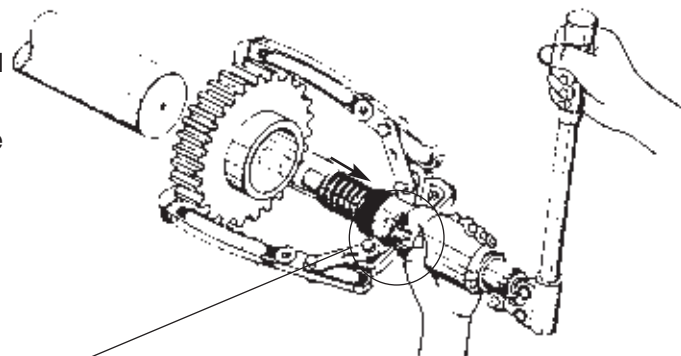
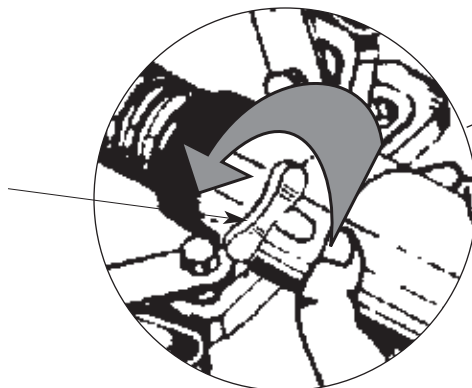
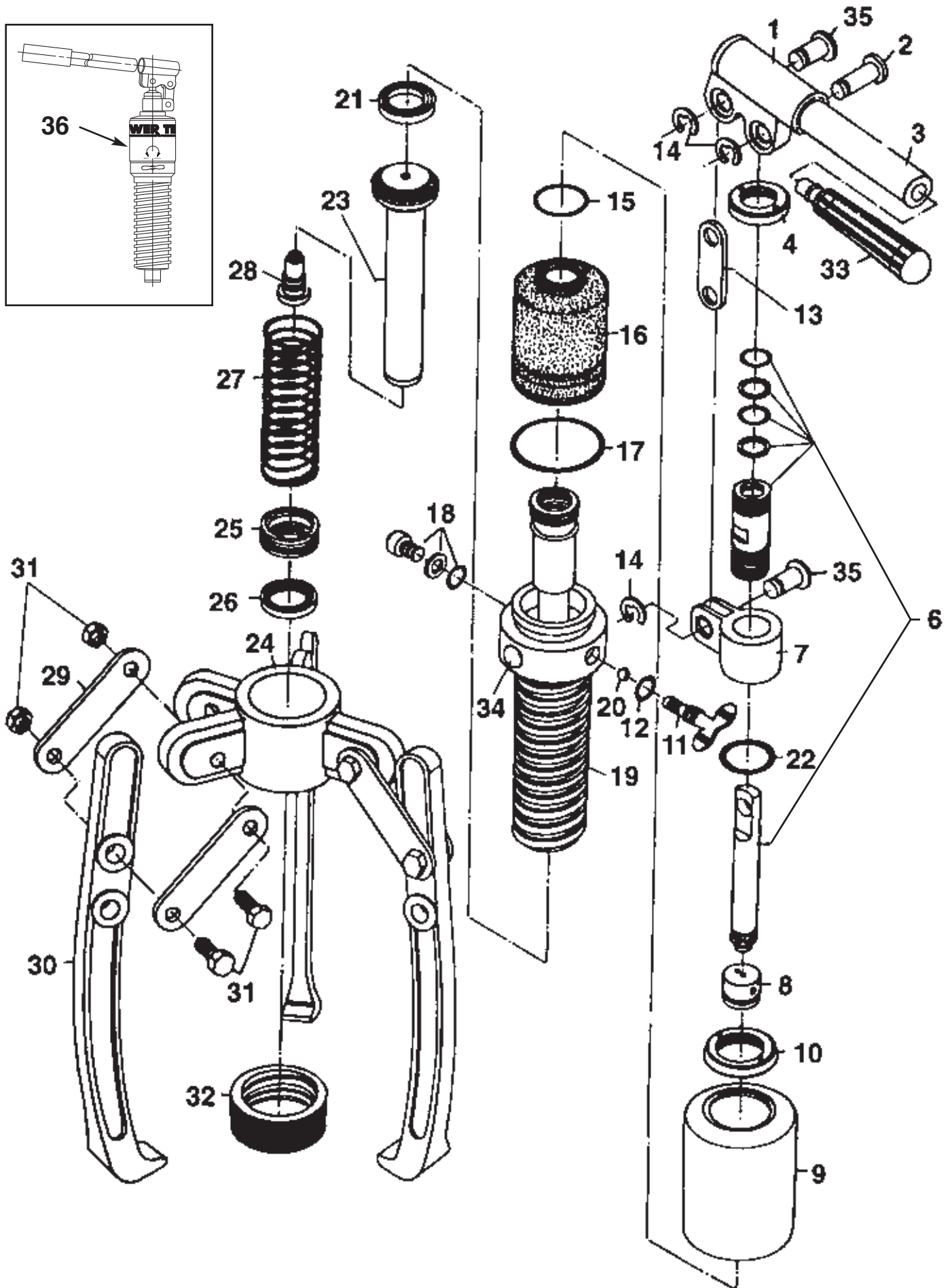

Nº artículo	Nº pieza (For PH63C)	Nº pieza (For PH83C)	Nº pieza (For PH113C)	Cant. necesaria	Descripción
1	252926	252926	252926	1	Abrazadera de la manivela
2	252933	252933	252933	1	Pasador de la abrazadera (largo)
3	252936	252936	252936	1	Palanca de la manivela
4	252941	252941	252941	1	Tuerca de retención
6	252914	252914	252914	1	Conjunto de alojamiento del pistón de la bomba
7	252912	252912	252912	1	Abrazadera basculante
8	252913	252913	252913	1	Conjunto de válvula de entrada/salida
9	252908	252909	252910	1	Alojamiento de la cámara
10	252911	252911	252911	1	Tuerca de retención del alojamiento de la cámara
11	252903	252904	252904	1	Perilla de la válvula de control
12	252902	252902	252902	1	Junta tórica
13	252925	252925	252925	1	Unión de sujeción
14	252932	252932	252932	3	Anillo de retención
15	252887	252887	252887	1	Anillo de compresión (pequeño)
16	252905	252906	252907	1	Cámara de depósito
17	252888	252889	252890	1	Anillo de compresión (grande)
18	252900	252900	252900	1	Conjunto de tornillo de carga de aceite
19	252894	252895	252896	1	Cuerpo de extractor hidráulico
20	252901	252916	252916	1	Bola de acero
21	252937	252938	252939	1	Junta hermética en U
22	252940	252940	252940	1	Junta tórica
23	252891	252892	252893	1	Biela del pistón del extractor
24	252917	252918	252919	1	Cabezal del extractor
25	252882	252883	252884	1	Tuerca de retención cilíndrica
26	252934	252934	252935	1	Leva de biela
27	252885	252886	252886	1	Muelle de compresión
28	252929	252929	252931	1	Conjunto de cono extraíble
29	252923	252924	252924	6	Articulación del extractor
30	252920	252921	252922	3	Mordaza del extractor
		*30902	*30902	3	Mordaza del extractor larga (opcional)
31	252927	252928	252928	6	Tuerca y tornillo de la mordaza del extractor
32	252897	252898	252899	1	Tuerca de fijación
33	252957	252957	252957	1	Conjunto del mango de la manivela
34	---	---	---	1	Consultar nota a continuación
35	252951	252951	252951	2	Pasador de la abrazadera (corto)
36	PH6	PH8	PH11	1	Conjunto hidráulico de repuesto completo, con manivela

PIEZAS INCLUIDAS QUE NO APARECEN EN LA ILUSTRACIÓN

351491	351492	351493	1	Etiqueta con nombre comercial
252948	252949	252950	1	Maletín de plástico

*Para solicitar un juego de tres mordazas largas, solicite la pieza número 1188.

NOTA: Los procesos de revisión y mantenimiento del conjunto de válvula de seguridad (art. nº 34) sólo pueden ser realizados por un centro de servicios hidráulicos cualificado. Para más información póngase en contacto con el centro de mantenimiento o con el Servicio técnico de Power Team más cercano.

PULLER PARTS LIST-PH303C

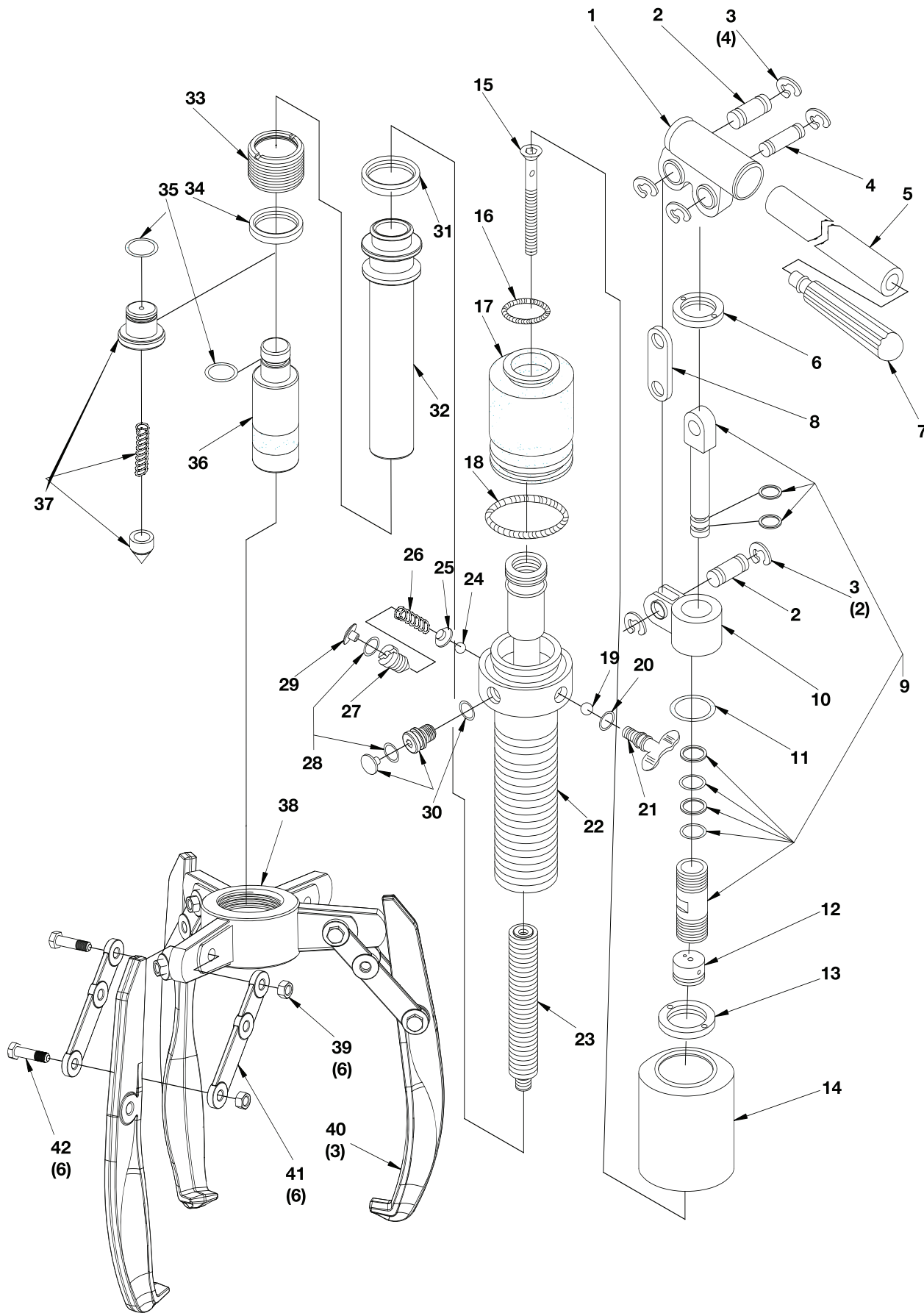

PH303C PULLER, HYD. GEAR 30 TON, W CASE & BLANKET

ITEM	SPX NO.	QTY P/N	DESCRIPTION
1	252926	1	Clevis, Handle
2	2000616	2	Pin, Clevis - Short
3	252932	6	Ring, Retaining
4	2000620	1	Pin, Clevis - Long
5	252936	1	Lever, Handle
6	252941	1	Nut, Retainer (Nut, Cylinder Retaining)
7	252957	1	Assembly, Handle Grip
8	252925	1	Link, Connector
9	252914	1	Assembly, Pump Housing Pump and Piston
10	252912	1	Clevis, Swivel
11	252940	1	O-ring
12	252913	1	Assembly, Inlet / Outlet Valve
13	2000599	1	Nut, Retainer Housing Bladder
14	2000598	1	Housing, Bladder
15	2000621	1	Screw, Drag Spring
16	252887	1	Ring, Compression - Small (Spring)
17	2000601	1	Bladder, Reservoir
18	2000602	1	Ring, Compression - Large (Spring)
19	252916	1	Ball, Steel .250"
20	252902	1	O-ring
21	2000600	1	Knob, Valve Control
22	2000603	1	Body, Hydraulic Puller
23	2000622	1	Spring, Drag
24		1	
25		1	
26		1	
27		1	
28		2	
29		1	
30	2000629	1	Screw, Ass'y Oil Fill
31	2000604	1	U-cup
32	2000605	1	Rod, Piston Puller
33	2000607	1	Nut, Cylinder Retaining
34	2000608	1	Wiper, Rod Nitrile
35	2000630	2	O-ring
36	2000631	1	Adapter
37	2000632	1	Cone Assembly, Removable
38	2000606	1	Crosshead, Puller
39	2000614	6	Nut, Puller Jaw
40	2000612	3	Jaw, Puller
41	2000611	6	Strap, Puller
42	2000609	6	Screw, Puller Jaw
43			
44	2000613	3	Jaw, Long Puller (Optional, Not Shown)
45	2000617	1	Case, Metal Storage
46	2000618	1	Blanket, Protective
47	1000199	1	Decal
48	PH30	1	Pump, Replacement Assembly

NOTE: Relief Valve Assembly (Item #24–#29) must not be serviced except by a qualified hydraulic service center. Contact your nearest service center or Power Team Technical Services for further information.

PREVENTIVE MAINTENANCE

- Keep the puller as clean as possible to help prevent contamination from entering the hydraulic system and to prevent rust.
- If additional oil is needed, use Power Team hydraulic oil or a comparable jack oil.

- Reservoir oil capacity:

PH30 & PH303C = .68 pt (320 cc)

- Periodically lubricate puller pivot points.
- Store the puller and all accessories in its plastic case.

Sheet No. 4 of 5

Rev. 11 Fecha: 02 Sept 2011

INSTALACIÓN Y FUNCIONAMIENTO DE LA HERRAMIENTA ENDEREZADORA

1. Rosque la herramienta enderezadora al cuerpo del extractor. Consulte la figura 8.



ADVERTENCIA: La herramienta enderezadora debe estar completamente acoplada a la rosca del cuerpo del extractor, tal y como se muestra a continuación.



Figura 8

2. Coloque los brazos de la herramienta enderezadora a la misma distancia del centro del cuerpo del extractor usando las marcas que se encuentran en el cuerpo de la herramienta enderezadora. Consulte la figura 9.

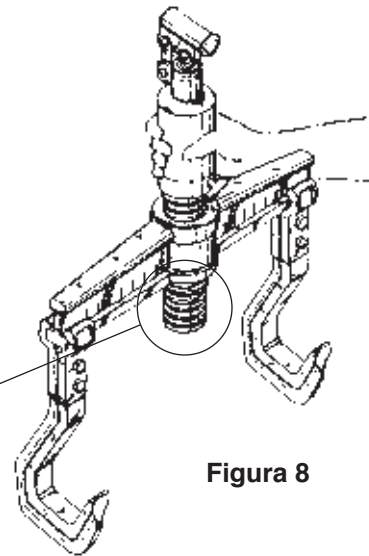
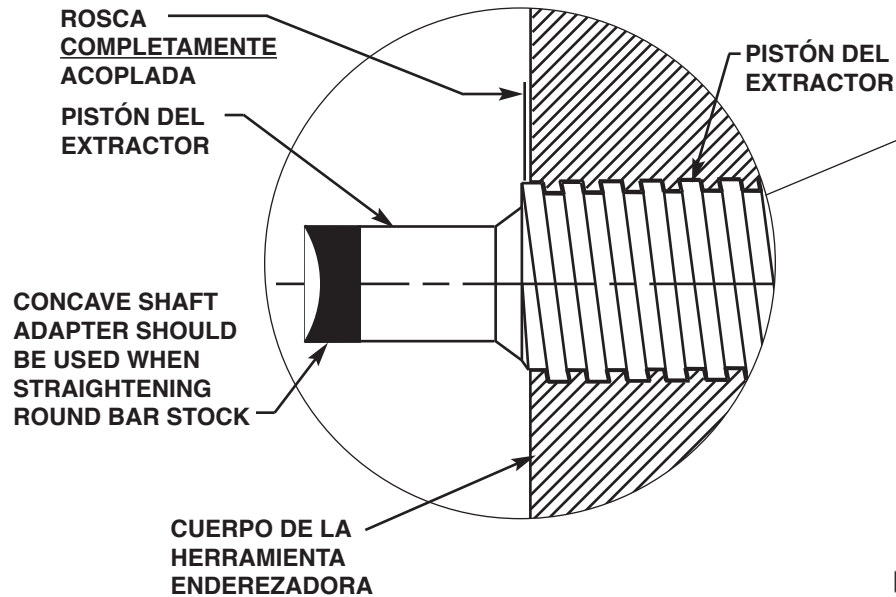

ADVERTENCIA: Una posición desigual de los brazos de la herramienta en el cuerpo de la enderezadora daría lugar a una situación muy peligrosa. La fuerza se distribuiría de forma desigual en cada brazo y esto podría provocar la avería de la herramienta y lesiones graves.

IMPORTANTE: NO UTILICE CALOR, MARTILLOS NI HERRAMIENTAS DE IMPACTO EN LOS EXTRACTORES. PROVOCARÁ DAÑOS QUE ANULAN LA GARANTÍA DEL EXTRACTOR.

3. Coloque el conjunto de la manivela en la abrazadera. Consulte la figura 9.

4. Coloque el extractor y la herramienta sobre la barra o barra cilíndrica que se va a enderezar. Gire completamente la perilla de la válvula de control en el sentido de las agujas del reloj para avanzar el pistón. Consulte la figura 9.



Figura 9

**INSTALACIÓN Y FUNCIONAMIENTO DE LA HERRAMIENTA
ENDEREZADORA (CONTINUACIÓN)**

5. Haga avanzar el pistón bombeando con la manivela hasta que la barra o la barra cilíndrica se enderece. Consulte la figura 10.

6. Gire completamente la perilla de la válvula de control en el sentido contrario al de las agujas del reloj para hacer retroceder el pistón. Consulte la figura 10.

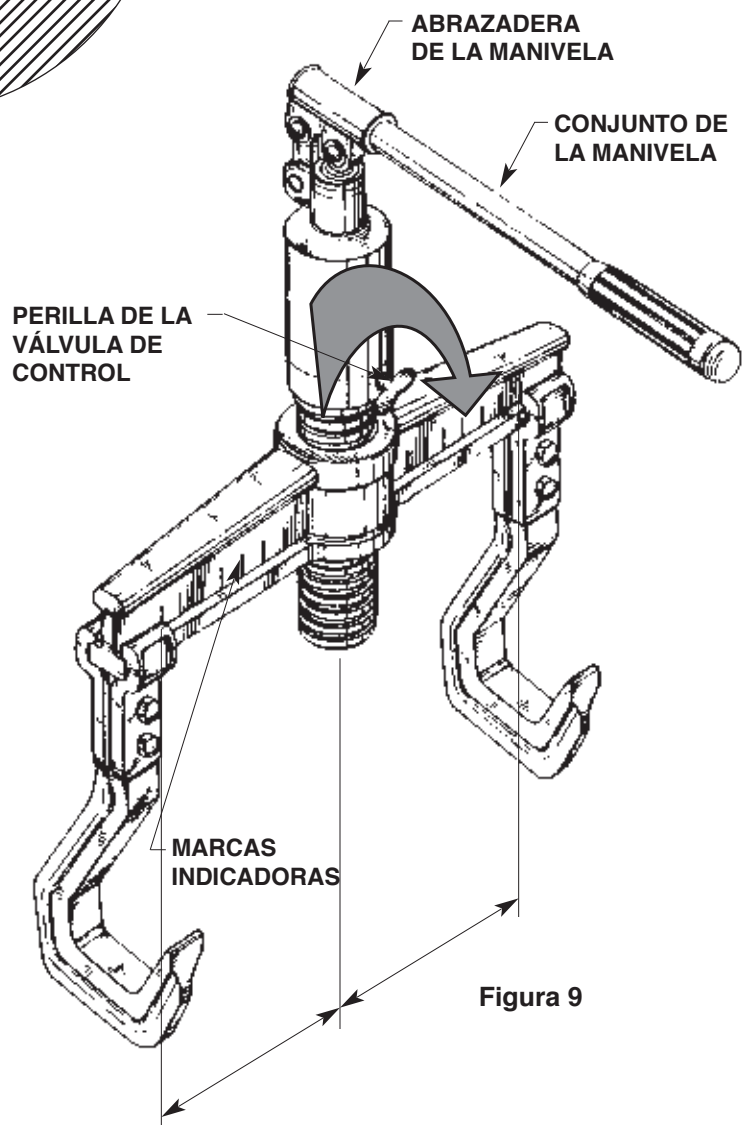
**ADAPTADOR
CÓNCAVO DE EJES**

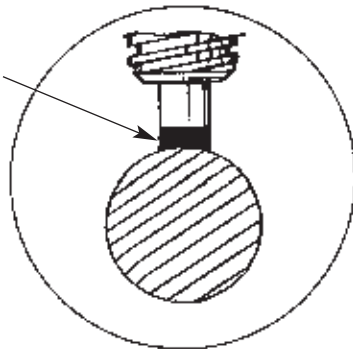

**PERILLA DE LA
VÁLVULA DE
CONTROL**



Figura 10

HST11 LISTA DE PIEZAS DE LA HERRAMIENTA ENDEREZADORA

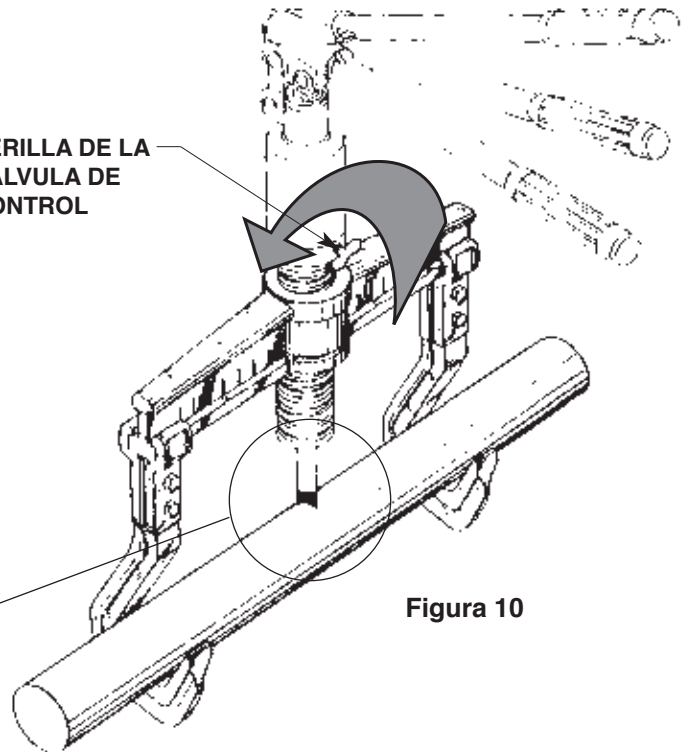
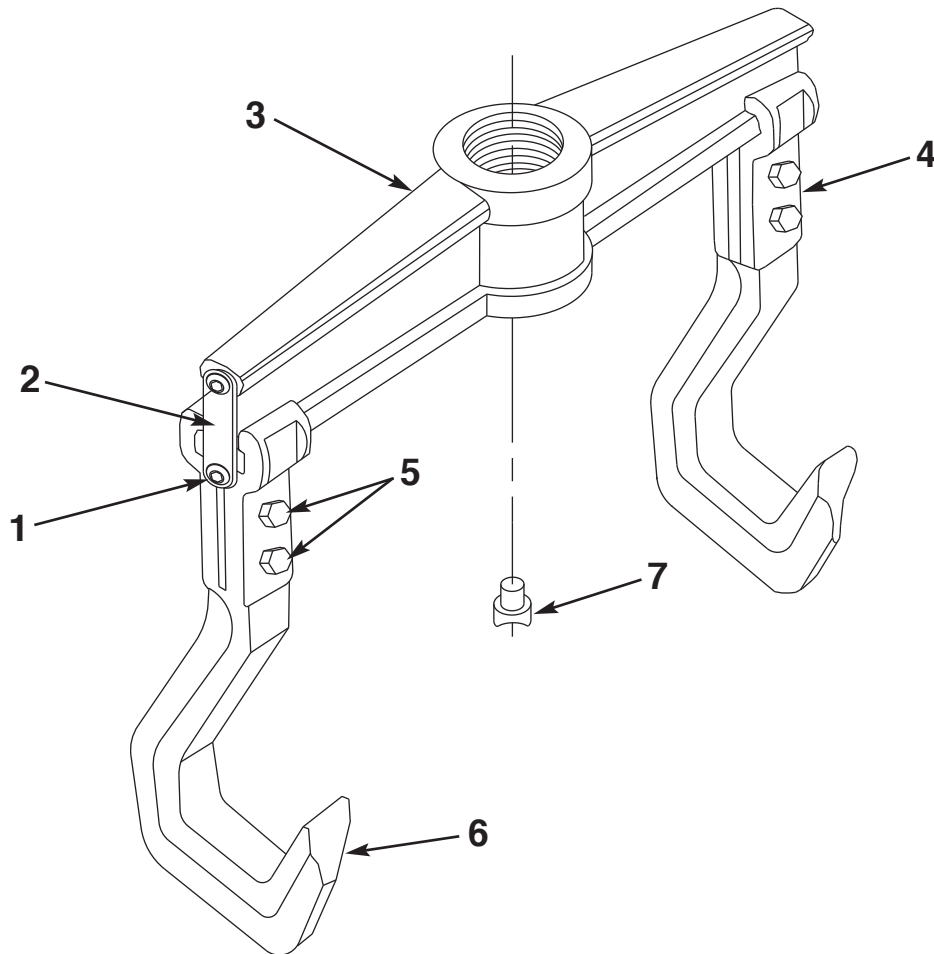

Nº artículo	Nº pieza	Cant. necesaria	Descripción
1	253042	4	Tornillo
2	253041	2	Articulación
3	253037	1	Travesaño
4	253038	2	Portamordazas
5	253040	4	Conjunto de perno y tuerca
6	253039	2	Brazo
7	253060	1	Sombbrero de pistón cóncavo (Montar en la biela del pistón del extractor)

PIEZAS INCLUIDAS QUE NO APARECEN EN LA ILUSTRACIÓN

222142	1	Etiqueta de advertencia
351563	1	Etiqueta con nombre comercial
PH11	1	Conjunto hidráulico de repuesto completo (con manivela; véase también el reverso de las páginas 2 de 4 y 3 de 4)

NOTA: HST11S es un juego que consta de la herramienta enderezadora HST11 y el extractor hidráulico con manivela PH11.