

Documentation in Accordance with EC Guideline 2006/42/EC for:

Equipment: **Aluminium gantry crane
with collapsible lateral stands
incl. park-brake trolley
incl. integrated horizontal adjuster**

Item No.: 1311040, 1311050, 1311060, 1311070, 1311080,
1311540, 1311550, 1311560, 1321040, 1321050,
1321060, 1321070, 1321080, 1321540, 1321550,
1321560, 1331040, 1331050, 1331060, 1331070,
1331080, 1331540, 1331550, 1331560

*for separable/pluggable beam versions additionally -10 (eg 1311040-10)

Serial number:

Date: 20/05/2015

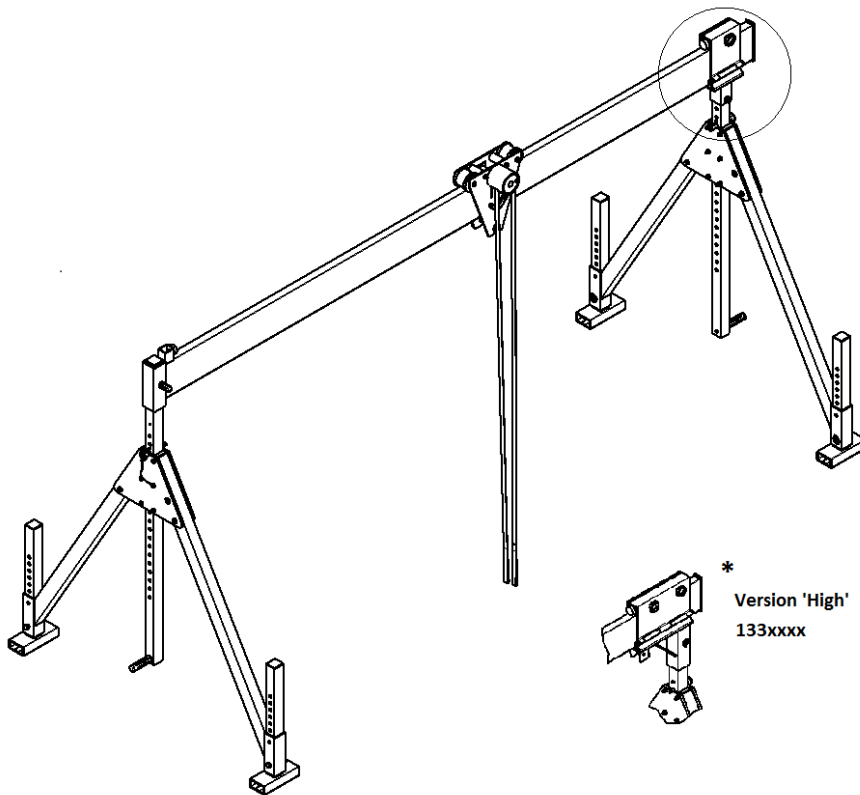

**Please read these instructions carefully before use and retain them for further use!
The documentation should accompany the product if transferred to third parties.**

Table of contents:

1. Field of application
2. Equipment-specific application guidelines
3. Assembling
4. Sources of hazard
5. Technical data
6. Safety regulations
7. Maintenance and repair
8. List of hazards
9. Basic safety regulations
10. EC Declaration of Conformity
11. Further documents

The item number, load capacity, serial number as well as the weight can be found on the engraving of the gantry crane.

Images and drawings in this documentation may differ slightly from the delivered product.

Please note that the load capacity must not be exceeded.

1. Field of application

The aluminium gantry crane is used for lifting and moving loads on even and fortified grounds.

2. Equipment-specific application guidelines

- 2.1 The aluminium double beam (7) must be exactly aligned horizontally and the beam support (4) vertically.
- 2.2 Before the aluminium gantry crane is used under load all plug-in-bolts (10,11) must be plugged in and (if necessary) be secured with clip-pins (13). Furthermore the push bolt (12) of the stand brace (2) always needs to be locked into the plastic-trapezium (3).
- 2.3 The crane trolley (8) can only be used on the beam part between the lateral stands.
- 2.4 Directions of the loads out of the level which is stretched through the alu-beam (7) and the beam supports (4) should be avoided (slant pullings).
- 2.5 The crane trolley (8) and -if used- the chain hoist must be removed before disassembling the crane. Or the brake of the trolley must be fastened.
- 2.6 During adjustment of the beam supports (4) the user needs to grab only the lifting handle (5) and the plug in bolts (10).
- 2.7 The equipment must be disassembled or anchored to the ground in case of wind speeds of more than 40 km/h .
- 2.8 The aluminium gantry crane can not be use on icy or slippery ground .
- 2.9 The temperature ranges for the operating conditions are -20 C° up to +50 C°.

3. Assembling

Record of single components:

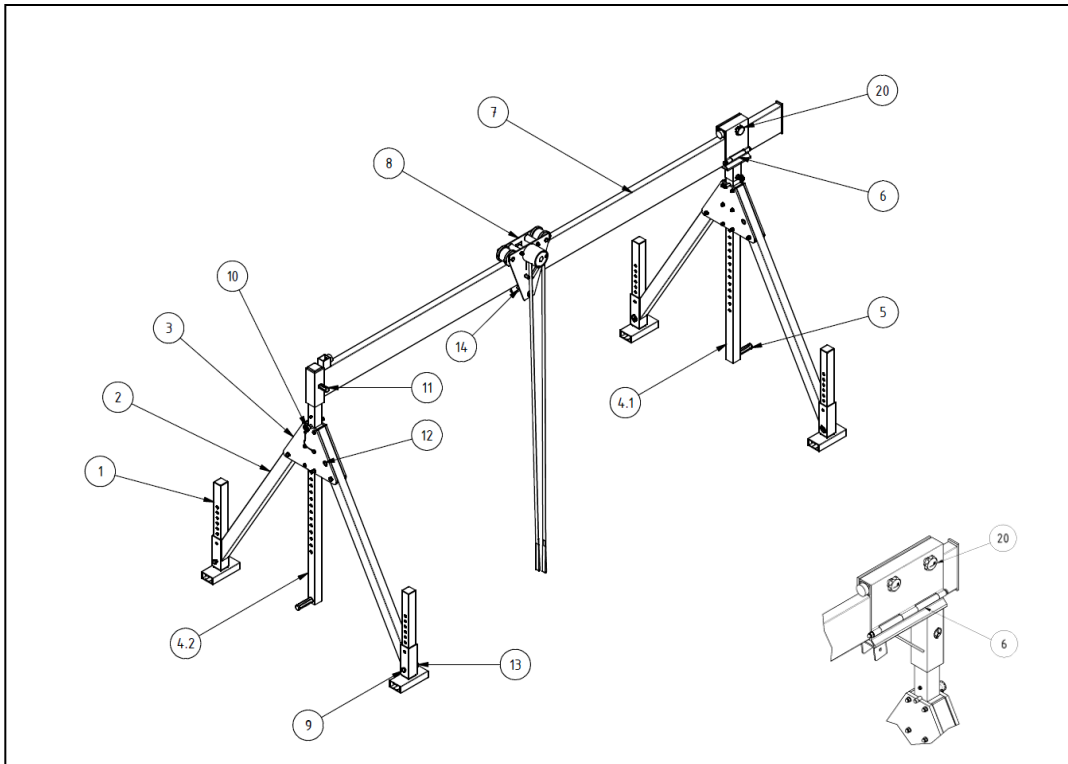

1	Adjusting-feet	8	Trolley
2	Stand brace	9	Bolt for adjusting-feet
3	Plastic plates (trapezium)	10	Bolt for beam support
4.1	Beam support short	11	Bolt for alu-beam
4.2	Beam support long	12	Push-bolt
5	Liftling handle	13	Clip pin
6	Horizontal adjuster	14	Plug-in bolt for trolley
7	Alu-beam	20	Star knob(s)

*** For separable/pluggable beam versions please also refer to the additional pages found at the end of this document**

3.1

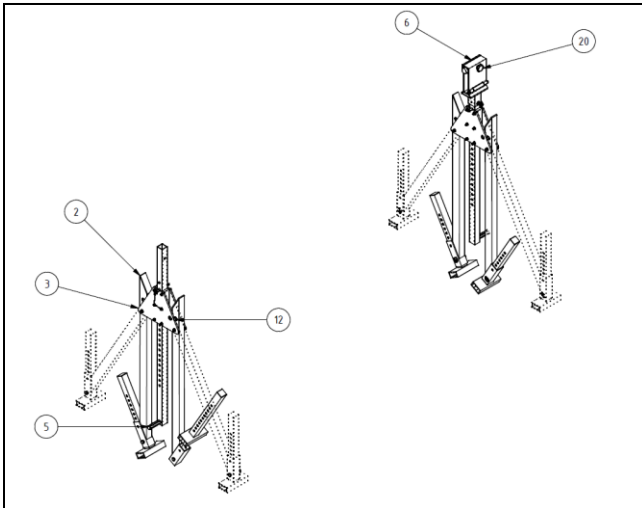

Press the push-bolt (12) provided on the stand brace (2) and open them until the push-bolts lock into place on the plastic plates (trapezium) (3). Loosen the star knob screw (20) and open the lid of the horizontal adjuster.

3.2

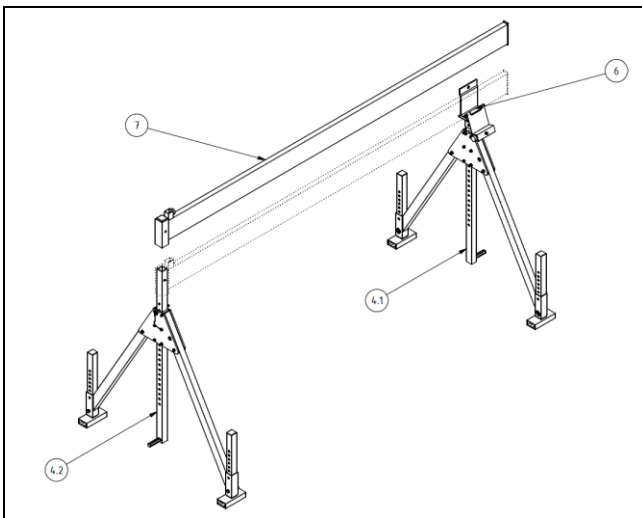

Now put the alu-beam (7) onto the lateral stands. Make sure that the beam housing (alu-square-special-profile), which is welded onto one end of the alu-beam, will be plugged into the longer beam support (4.2). The other side of the alu-beam will be insert into the horizontal adjuster (6) on the shorter beam support (4.1).

3.3

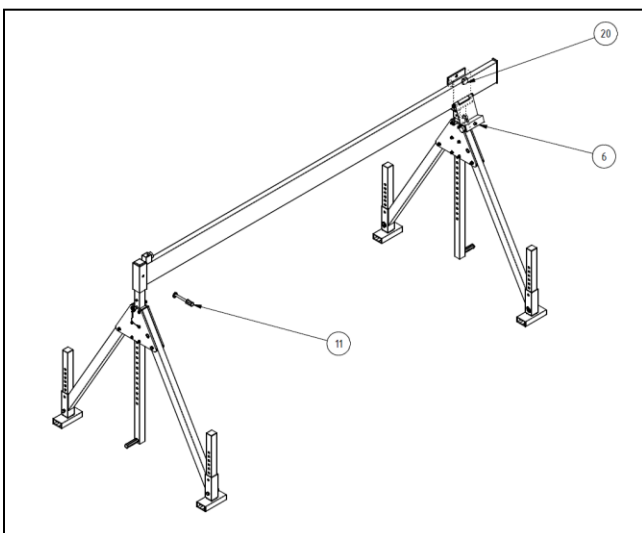

Plug the bolt (11) into the hole on the beam housing of the alu-beam and secure it with a clip pin. Now close the lid of the horizontal adjuster (6) and screw it together with the blue star knob(s) (20) in order to fix the alu-beam.

3.4

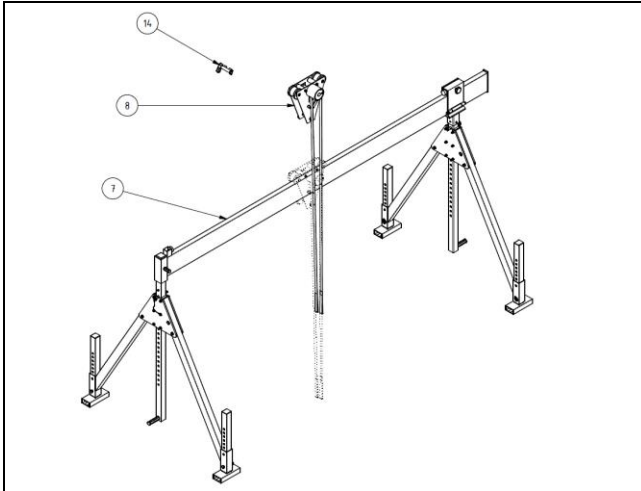

Next the trolley (8) will be placed onto the alu-beam (7). Fasten it with the plug-in bolt (9) and secure it with a clip pin (14) and secure it with a clip pin.

Fix the trolley against unwanted moving by pulling the red belt.

3.5

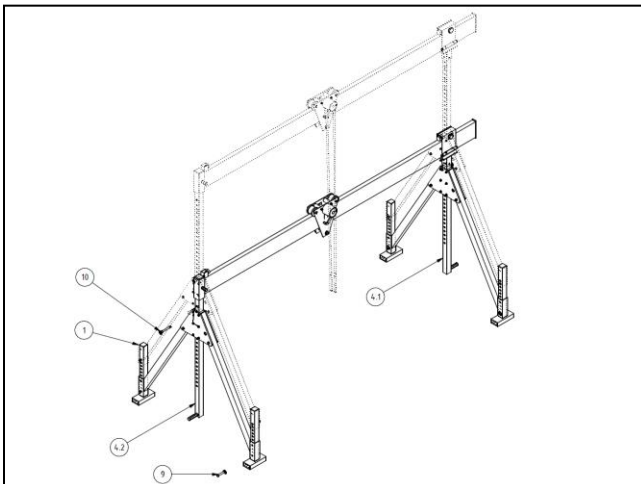

In the last step adjust the required working height by extending the alu-adjusting-feet (1) and respectively or the beam support (4.1, 4.2) and fix the applicable height with a plug-in bolt (9, 10).

3.6 Proceed exactly in the reverse order when disassembling. Please make sure that the crane trolley is removed from the alu-beam first or fixed with the brake. The trolley will be fixed by pulling the red band and released by pulling the green band.

4. Sources of Hazard

- 4.1 In the event that the brake of the trolley (8) is not fastened and the alu-beam (7) is slightly in an inclined position the trolley will start moving.
- 4.2 Use not in accordance with the instructions can lead to injuries during adjustment of the beam supports (4).
- 4.3 Open up and close the stand brace (2) slowly as fingers can be bruised.
ATTENTION: danger of bruising for fingers!
- 4.4 If the distance between the two lateral stands is very low the stability of the aluminium gantry crane must be assured.
- 4.5 The aluminium gantry crane may fall over in the event of wind speeds exceeding 40 km/h.
- 4.6 Important parts may break in the event of cracks in the weld seams.

5. Technical Data

Item number	1311040	1311050	1311060	1311070	1311080
Load capacity	1000 kg	1000 kg	1000 kg	1000 kg	1000 kg
Beam length	4000 mm	5000 mm	6000 mm	7000 mm	8000 mm
Total weight approx.	91 kg	103 kg	117 kg	126 kg	167 kg
Item number	1311540	1311550	1311560		
Load capacity	1500 kg	1500 kg	1500 kg		
Beam length	4000 mm	5000 mm	6000 mm		
Total weight approx.	99 kg	128 kg	141 kg		
Item number	1321040	1321050	1321060	1321070	1321080
Load capacity	1000 kg	1000 kg	1000 kg	1000 kg	1000 kg
Beam length	4000 mm	5000 mm	6000 mm	7000 mm	8000 mm
Total weight approx.	97 kg	109 kg	123 kg	132 kg	173 kg
Item number	1321540	1321550	1321560		
Load capacity	1500 kg	1500 kg	1500 kg		
Beam length	4000 mm	5000 mm	6000 mm		
Total weight approx.	105 kg	134 kg	147 kg		
Item number	1331040	1331050	1331060	1331070	1331080
Load capacity	1000 kg	1000 kg	1000 kg	1000 kg	1000 kg
Beam length	4000 mm	5000 mm	6000 mm	7000 mm	8000 mm
Total weight approx.	149 kg	161 kg	175 kg	184 kg	225 kg
Item number	1331540	1331550	1331560		
Load capacity	1500 kg	1500 kg	1500 kg		
Beam length	4000 mm	5000 mm	6000 mm		
Total weight approx.	157 kg	186 kg	199 kg		

*for separable/pluggable beam versions additionally -10 (eg 1311040-10)

* Total weight per Crane type increased by approx. 5 kg through the addition of separable/pluggable beams

6. Safety Regulations

- 6.1 The Employer's Liability Insurance Association regulation BGV D6 applies.
- 6.2 **Personal Requirements**
The aluminium gantry crane may only be operated by authorized personnel. Each operator must have read and understood this documentation.
- 6.3 **Functional Check and Visual Inspection prior to each Use**
The aluminium gantry crane must be subjected to a functional check and visual inspection prior to each use. Especially load-carrying parts and weld seams must be checked for damage. Do not operate in case of faults. They must be eliminated by a skilled person.
- 6.4 **Requirement for Inspection**
The operating company must take care that the aluminium gantry crane is checked by a skilled person at intervals of no longer than one year, and that any faults are immediately eliminated. The regulations of BGV D6, chapter III should be observed.
- 6.5 **Unauthorized Modification**
Unauthorized modification of the aluminium gantry crane or self-constructed additional equipment is not allowed.

7. Maintenance and Repair

The aluminium gantry crane normally does not require any maintenance.
Any repair work may only be performed by persons having the necessary skills and knowledge.
Before setting the crane into operation again, it must be subjected to an extraordinary inspection by an expert.

8. List of Hazards in Accordance with DIN EN ISO 12100

Pos.	Hazards	Body parts	Solution/Warning
1	-Location -its mass and stability -its mass and acceleration -insufficient -mechanical stability	Persons Operator and third persons Operator and third persons Operator and third persons	Warning label on the crane Instruction/initiation Instruction/initiation Observe user and maintenance Manuals
1.1	Contusion	by load / Operator and third persons	Observe safety distances / Observe pendulum movement of the load and stopping distances
	Contusion	Operator	Observe safety distances
	Contusion	Limit stop / operator	Observe safety distances
	Contusion	by load to the environment Operator / foot	Observe safety distances
1.2	Shearing	Trolley - road / wall - support Operator, hand	Observe safety distances/ Observe pendulum movement of the load Ensure sidestep and return possibilities
1.6	Shock	Load pendulum movement / operator	Observe safety distances
1.10	Throwing out of parts	Load/operator	Observe safety distances
1.11	Stability	Underground, ground / operator	Leave danger zone if possible, lower load immediately, stop crane, only put crane and load on a sufficiently stable ground
1.12	Slipping, stumbling, falling	insufficient stability / operator	Keep operating ways free, ensure sufficient stability
2.	Electrical hazard		
2.1	Electrical contact	damaged insulation of el. conductors, supply lines, operator	Stop operation, cut off power supply, replace el. conductor, lay supply line safely contact to operator prohibited
2.4	External effect	e.g. on supply line by other means of transport/operator or third persons	Observe crane, load and environment attentively
3.1	Burns	el. operated crane / operator	Particularly observe regulations in potentially explosive area
7	Materials (oils, greases, lubricants)	Turning drive / hoisting device Operator / third persons/environment	refer to special user manual for hoists and drives
7.2	Fire and explosion	el. operated crane Operator and third persons	Not suitable for potentially explosive areas
8.4	Maladjusted local lighting	Operator / third persons	Ensure sufficient visibility
8.6	Human wrongdoing	Operator	Training
10+ 10.3	Fault of energy supply Malfunction control system	Operator / third persons	Operate emergency stop and take troubleshooting measures by a specialist
10.4	Incorrect assembly	Operator	Stop operation Eliminate trouble
10.5	Racing, unexpected loss of stability of the machine	Operator	Lower load, secure crane
11	Failure/wrong disposition of protection measures	Operator	Take all measures to reduce hazard potential
11.1+ 11.2	Protection equipment	Operator / third persons	Check protection equipment
11.3	Start and brake systems	Wheel+steering stop / operator	press wheel + steering stop before operation
	Start and brake systems	Control panel / operator	Press emergency stop if control button is defective Replace parts
11.4+ 11.5	Safety symbols/signals Information and warning equipment	Mains switch Emergency stop / operator	Check function before starting work
11.6	Energy supply cutoff	Mains switch Emergency stop / operator	Check function before starting work
11.7	Emergency measures	Work area / operator	Press emergency stop if danger is reduced in this way
11.9	Equipment for safe setting and/or maintenance	Operator	Lock mains switch in "Off" pos. before any work

9. Basic Safety Regulations

9.1.1 Warnings and Symbols

The designations and symbols listed hereafter are used in the user manual for very important information

Note Special information on the economic use of the equipment/machine.

Attention Special information or regulations and prohibitions for damage prevention.
Danger Special information or regulations and prohibitions for prevention of important material damages or personal injuries

9.1.2 Principle, Intended Use

9.1.2.1 The machine/equipment has been built in accordance with the current and approved safety regulations. However, risks for life or physical condition of the operator or third persons or damages to the machine or other real values may occur.

9.1.2.2 Use the equipment/machine only in perfect technical condition and according to the intended use, be aware of safety and risks and observe the user manual! Immediately repair (have repaired) especially faults that may impair safety!

9.1.2.3 The machine/equipment should only be used for lifting and moving loads. Any other use or any use beyond that e.g. pulling loads is considered as contrary to the intended use. The manufacturer/supplier is not responsible for any damages resulting from this. The user bears all risk.

The intended use also includes observing the user manual and the inspection and maintenance conditions.

9.1.3 Organizational Measures

9.1.3.1 Keep this user manual readily available at the place of installation of the machine/equipment (in the tool compartment or in the compartment provided for this purpose)!

9.1.3.2 In addition to the user manual, all general legal regulations as well as other binding rules concerning prevention of accidents and environmental protection should be observed

9.1.3.3 Complete the user manual with regulations incl. supervision and notification obligations, taking into account the special features of the company regarding work organization, operating sequences and charged personnel.

9.1.3.4 The personnel charged with the work on the machine must have read the user manual and especially the chapter Safety Regulations before starting work. Reading the manual during work is too late. This applies especially to the personnel that works only occasionally on the machine, e.g. for setting up or maintenance.

9.1.3.5 Check periodically whether personnel are aware of safety and risks during work and observe the user manual.

9.1.3.6 The personnel must not have long open hair nor wear loose clothes or jewelry incl. rings. Risk of injuries e.g. by getting caught or being pulled in.

9.1.3.7 Use personnel protection equipment if necessary or required by regulations

9.1.3.8 Take notice of all safety and danger signs on the machine/equipment!

9.1.3.9 Make sure that all safety and danger signs on the machine are always legible!

9.1.3.10 In case of changes regarding safety of the machine/equipment and its operating behaviour, stop the machine/equipment immediately and inform the responsible department/person of the fault!

- 9.1.3.11 Do not perform any changes or modifications to the machine/equipment that could affect the safety without approval of the supplier. This also applies to the mounting and setting of the equipment and safety valves as well as to the welding of supporting parts.
- 9.1.3.12 The spare parts should meet the technical requirements specified by the manufacturer. This is always guaranteed if the original spare parts are used.
- 9.1.3.13 Observe the periods for the checks/inspections stipulated or specified in the user manual!
- 9.1.3.14 A suitable workshop equipment is necessary for performing the maintenance work .
- 9.1.3.15 Indicate the location and the handling of fire extinguishers!
- 9.1.3.16 Observe the fire alarm and fire fighting possibilities!

9.1.4 Personnel Selection and Qualification – Basic Duties

- 9.1.4.1 Work on the machine/equipment must only be performed by reliable personnel. Observe the legal minimum age!
- 9.1.4.2 Only deploy trained and instructed personnel, clearly define the competences of the personnel for operation, setting, maintenance, repair!
- 9.1.4.3 Make sure that only authorized personnel work on the machine!
- 9.1.4.4 Define the responsibility of the machine operator – also regarding traffic regulations – and allow him to refuse instructions by third persons that are contrary to safety!
- 9.1.4.5 Only allow personnel to be trained, instructed or working within the scope of a general training to work under the permanent supervision of an experienced person on the machine/equipment!
- 9.1.4.6 Work on the electrical equipment of the machine/equipment must only be performed by a specialist in electricity or other instructed persons under the direction and supervision of a specialist in electricity in accordance with the electro technical rules.
- 9.1.4.7 Work on the running gears, braking and steering systems must only be performed by a specialized and instructed personnel!

9.1.5 Safety Regulations regarding the different Operating Phases

- 9.1.5.1 Normal operation
 - 9.1.5.1.1 Avoid any working method that is critical regarding safety!
 - 9.1.5.1.2 Get acquainted with the work environment on the site before starting work. The work environment includes e.g. obstacles in the work and traffic area, the safe floor load and the necessary protection of the building site against the public traffic zone.
 - 9.1.5.1.3 Take adequate measures to operate the machine/equipment only in a safe and operative state! Operate the machine only if all protection and safety equipments such as detachable protection equipment, emergency stops, sound insulation equipment, suction devices are available and operative!
 - 9.1.5.1.4 Check the machine/equipment at least once per shift to detect external damages and faults. Inform the responsible department/person immediately of any changes (incl. changes in the operating behaviour). If necessary, stop and lock the machine immediately.
 - 9.1.5.1.5 In case of malfunctions, stop and lock the machine/equipment immediately! Have the malfunctions repaired without delay!
 - 9.1.5.1.6 Observe the switch-on and off procedures and the indicator lamps in accordance with the user manual!
 - 9.1.5.1.7 Make sure before switching on/starting the machine/equipment that nobody is put at risk by the startup of the machine/equipment !
 - 9.1.5.1.8 Check before the trip/starting work that brakes, steering, signaling and lighting system are operative!

- 9.1.5.1.9 Make sure that the accessories are well placed in case of accidents before moving the machine!
- 9.1.5.1.10 Always switch on the lights in case of reduced visibility or darkness!
- 9.1.5.1.11 Always observe a sufficient distance when passing undercrossings, bridges, tunnels, overhead lines, etc!
- 9.1.5.1.12 Always keep sufficient distance to edges of foundation ditches and slopes!
- 9.1.5.1.13 Avoid any working method affecting the stability of the machine!
- 9.1.5.1.14 Do not drive crosswise on slopes; always carry the equipment and the loaded material near the ground, especially when driving down a slope!
- 9.1.5.1.15 When leaving the machine, always lock it in order to prevent it from moving unintentionally and protect it against unauthorized use.

- 9.1.5.2 Special work within the use of the machine/equipment and maintenance work as well as troubleshooting during work flow, disposal.
- 9.1.5.2.1 Observe the work and dates specified in the user manual for setting, maintenance and inspection incl. information on replacing parts/equipment parts! These operations have to be performed by a skilled personnel.
- 9.1.5.2.2 Inform the operating staff before proceeding to special and maintenance work! Appoint the supervising person!
- 9.1.5.2.3 For all work regarding operation, adjustment of production, changing and setting of the machine/equipment and the safety equipment as well as inspection, maintenance and repair, the startup/stop sequences according to the user manual and the guidelines concerning repair work have to be observed!
- 9.1.5.2.4 Protect the maintenance area widely if necessary!
- 9.1.5.2.5 If the machine is completely switched off for maintenance and repair work, it has to be protected against any unexpected restart.
 - Lock the main control units and remove the key and/or
 - Put a warning sign on the main switch.
- 9.1.5.2.6 Only proceed to maintenance or repair work if the machine is placed on even and solid ground and protected against moving and buckling!
- 9.1.5.2.7 Parts and bigger subassemblies have to be fixed carefully on the hoisting devices so that there is no danger. Only use hoisting devices in perfect condition and load suspension devices of sufficient carrying load! Do not stand or work under suspended loads.
- 9.1.5.2.8 Only experienced persons should be charged with attaching loads and guiding crane operators! The charged person should be within the range of vision of the operator or be in direct radio contact with him .
- 9.1.5.2.9 Use the climbing aids or platforms provided for this purpose or others for performing assembly work above body height. Do not use parts of the machine as climbing aids! Wear fall protections for maintenance work at big height!
Make sure that handles, steps, rails, platforms and ladders are free from dirt, snow and ice!
- 9.1.5.2.10 Remove oil, fuel and cleaning agents from the machine and especially from the connections and screw fittings before proceeding to maintenance/repair work. Do not use any aggressive cleaning products! Use fibre-free cloths !
- 9.1.5.2.11 Cover/glue up all ports where water/steam/cleaning product should not penetrate for functional or safety reasons before cleaning the machine with water or steam jet (high-pressure cleaning device). Electric motors and switch cabinets must be particularly protected.
- 9.1.5.2.12 Completely remove the covers/glue after cleaning!
- 9.1.5.2.13 Always tighten slackened screw fittings during maintenance and repair work!

- 9.1.5.2.14 If it is necessary to remove safety equipment for setting, maintenance and repair, remount and check the safety devices immediately after maintenance and repair work.
- 9.1.5.2.15 Ensure the safe and ecological disposal of fluids and auxiliary material as well as of exchanged parts!

9.1.6 Information regarding Special Hazard Types

- 9.1.6.1 Electric energy
 - 9.1.6.1.1 Only use original fuses with the specified intensity! Stop the machine immediately in case of malfunctions of the electric power supply!
 - 9.1.6.1.2 Make sure that there is a sufficient distance between the machine/equipment and the electric overhead lines! When working near overhead lines make sure that the equipment is not near the lines.
Danger of life! Inform yourself about the safety distances that have to be observed!
 - 9.1.6.1.3 After each contact with powerlines
 - Do not leave the machine
 - Move the machine out of the danger zone
 - Caution the external persons against getting closer and touching the machine
 - Arrange for cut off of power supply
 - Only leave the machine if the touched/damaged line is current free
 - 9.1.6.1.4 Work on electrical equipment or facilities has to be performed by a specialist in electricity or other instructed persons under the direction and supervision of a specialist in electricity in accordance with the electrotechnical rules .
 - 9.1.6.1.5 If specified, the power supply of machine/equipment parts on which inspection, maintenance and repair work is performed must be cut off. Check first whether the parts are current free, then connect to ground and short-circuit them and insulate them against adjacent live parts!
 - 9.1.6.1.6 Inspect/check the electrical equipment of a machine/equipment at regular intervals. Immediately repair faults such as slackened connections or scorched cables.
 - 9.1.6.1.7 If work on live parts is necessary, call in a second person that operates the emergency stop or main switch in case of emergency. Close off the work area with a red/white safety chain and a warning sign. Use insulated tools!
 - 9.1.6.2 Gas, dust, steam, smoke
 - 9.1.6.2.1 Observe the valid regulations for the respective place of use !
 - 9.1.6.2.2 Only perform welding, burning and grinding work if explicitly authorized, e.g. risk of fire and explosion !
 - 9.1.6.2.3 Remove any dust and combustible material from the machine/equipment and its environment and ensure sufficient ventilation (risk of explosion) before proceeding to welding, burning and grinding work)!
 - 9.1.6.3 Hydraulic system, pneumatic system
 - 9.1.6.3.1 Check all lines, hoses and screw fittings at regular intervals in order to detect leaks and external damage! Repair damages immediately! Squirting oil may cause injuries and fire.
 - 9.1.6.3.2 Decrease pressure of the system segments and pressure pipes (hydraulic, pneumatic) that have to be opened in accordance with the subassembly descriptions before proceeding to repair work !
 - 9.1.6.3.3 Lay and mount hydraulic and pneumatic pipes correctly! Do not mix up the connections! Fittings, length and quality of the hose pipes should meet the requirements.

- 9.1.6.4 Noise
- 9.1.6.4.1 The sound insulation devices on the machine/equipment must always be in protecting position during operation.
- 9.1.6.4.2 Wear the stipulated personal ear protection!
- 9.1.6.5 Oils, greases and other chemical substances
- 9.1.6.5.1 Observe the valid safety regulations of the product for handling oils, greases and other chemical substances!
- 9.1.6.5.2 Be careful when handling hot fluids and auxiliary materials (risk of burns and scalds!)
- 9.1.7 Transport; restart**
- 9.1.7.1 Use only suitable means of transport and hoisting devices of sufficient lifting capacity!
- 9.1.7.2 Proceed in accordance with the user manual for restart!

10. EC Declaration of Conformity in Accordance with EC Guideline 2006/42/EC

We herewith confirm that the

**Aluminium gantry crane
with collapsible lateral stands
incl. park-brake trolley
incl. integrated horizontal adjuster**

Item-No.: 1311040, 1311050, 1311060, 1311070, 1311080,
1311540, 1311550, 1311560, 1321040, 1321050,
1321060, 1321070, 1321080, 1321540, 1321550,
1321560, 1331040, 1331050, 1331060, 1331070,
1331080, 1331540, 1331550, 1331560

*for separable/pluggable beam versions additionally -10 (eg 1311040-10)

Serial number:

with a load capacity of 1,000 kg and 1,500kg complies with the safety regulations.

The CE mark is visible on the product.

Manufacturer:



▣ SCHILLING Gerätebau e.K.
▣ Ernst-Zimmermann-Str. 9-11
▣ 88045 Friedrichshafen
▣ Deutschland
▣ Telefon: +49 7541 60404-0
▣ Fax: +49 7541 60404-20
▣ E-Mail: mail@schilling-fn.de

Relevant EC guidelines:

EC machinery directive 2006/42/EC

Applied harmonized standards, especially:

DIN EN ISO 12100 safety of machines, devices and facilities

Steel: DIN EN 13001-3-1:2012

Aluminium: DIN EN 1999-1-1:2010-05

Applied national standards and technical specifications, if applicable, especially:

DIN EN 15011:2011-05

BGV D 6 (VGB 9) Cranes

Date: 20.05.2015

Signature:

Information on the undersigned: manufacturer

11. Further documents

Recurring inspection

Product: **Aluminium gantry crane
with collapsible lateral stands
incl. park-brake trolley
incl. integrated horizontal adjuster**

Manufacturer: SCHILLING Gerätebau, Friedrichshafen – www.schilling-fn.de
Build year: 2015

The item number, load capacity, serial number as well as the weight can be found engraved on the gantry crane.

1) Inspection before delivery
Sight and functional inspection of the aluminium gantry crane and its components is completed.
The product was developed, constructed and produced according to the rules of engineering.



Date: Dispatch day (compare delivery note)

Signature Owner/Manufacturer

2) Recurring inspection
The inspection is completed.

Date:

Signature Expert

3) Recurring inspection
The inspection is completed.

Date:

Signature Expert

4) Note
The inspection is completed.

Date:

Signature Expert

Next inspection: one year after delivery

Recurring inspection

Product: **Aluminium gantry crane
with collapsible lateral stands
incl. park-brake trolley
incl. integrated horizontal adjuster**

Manufacturer: SCHILLING Gerätebau, Friedrichshafen – www.schilling-fn.de
Build year: 2015

The item number, load capacity, serial number as well as the weight can be found engraved on the gantry crane.

Findings / draft			
The named defects have been fixed by -us / -the company .			
Date and signature of facility manager:			
There are -no- doubts for further use. Reinspection is -not- necessary.			
Date and signature of inspector:			
Noted.			
Date and signature of facility manager :			
Attendants:			
Lable:	yes	no	Inspection according §
Last inspection:			Inspection plate: yes no
Short statics made:	yes	no	Next inspection:

Recurring inspection

Note	Name and Company of Inspector
<p>The recurring inspection is completed.</p> <p>There are – no ´) – damages – compare Inspectionreport ´) page no. _____</p>	<p>_____</p> <p>(Date / Signature)</p>
<p>The recurring inspection is completed.</p> <p>There are – no ´) – damages – compare Inspectionreport ´) page no. _____</p>	<p>_____</p> <p>(Date / Signature)</p>
<p>The recurring inspection is completed.</p> <p>There are – no ´) – damages – compare Inspectionreport ´) page no. _____</p>	<p>_____</p> <p>(Date / Signature)</p>
<p>The recurring inspection is completed.</p> <p>There are – no ´) – damages – compare Inspectionreport ´) page no. _____</p>	<p>_____</p> <p>(Date / Signature)</p>
<p>The recurring inspection is completed.</p> <p>There are – no ´) – damages – compare Inspectionreport ´) page no. _____</p>	<p>_____</p> <p>(Date / Signature)</p>
<p>The recurring inspection is completed.</p> <p>There are – no ´) – damages – compare Inspectionreport ´) page no. _____</p>	<p>_____</p> <p>(Date / Signature)</p>
<p>The recurring inspection is completed.</p> <p>There are – no ´) – damages – compare Inspectionreport ´) page no. _____</p>	<p>_____</p> <p>(Date / Signature)</p>
<p>´) Please cancel the not applicable</p>	

Additional information for assembly of separable aluminium beam versions where applicable:



Step 1:



Step 2:



Step 3:



Step 4:



Step 5:

