

Aluminium Gantry Cranes, movable under load, load capacity 1,000 kg and 1,500 kg

Delivery contents:

2 pieces lateral stand, collapsible

with 2 height adjustable beam supports made of aluminium special profiles

- distance between holes: 50 mm

with 4 steel casters

- heavy-duty polyurethane lining
- with integrated caster and live ring brake
- diameter of caster 200 mm
- width of caster 50 mm

The lateral stands can be easily folded and can therefore space saving stored and transported.

1 piece aluminium special profile beam

1 piece park-break trolley

Into the trolley e.g. the hoist (chain hoist) or appropriate lifting bands will be hooked.

The trolley can be moved smoothly on the aluminium beam and can be fixed in any position.

2 pieces bump stop

Collision protection for the trolley

1 piece integrated horizontal adjuster

By the use of the horizontal adjuster the usable length of the Aluminium Gantry Crane can be adjusted smoothly between the two lateral stands.

The running track width of the aluminium beam is variable. This is a definite added value as well as a higher flexibility for the user.

The Aluminium Gantry Crane is equipped with a brace on both sides between the aluminium beam and the lateral stand.

This connection is due to more stability of the Aluminium Gantry Crane.

The Aluminium Gantry Crane System is a highly mobile, flexible, height and length adjustable, free standing construction.

The Aluminium Gantry Crane can be assembled and disassembled in a minimum of time with relatively few working steps.

There are no structural changes necessary (e.g. dowel fixture or the like).



Aluminium Gantry Cranes, movable under load, load capacity 1,000 kg and 1,500 kg

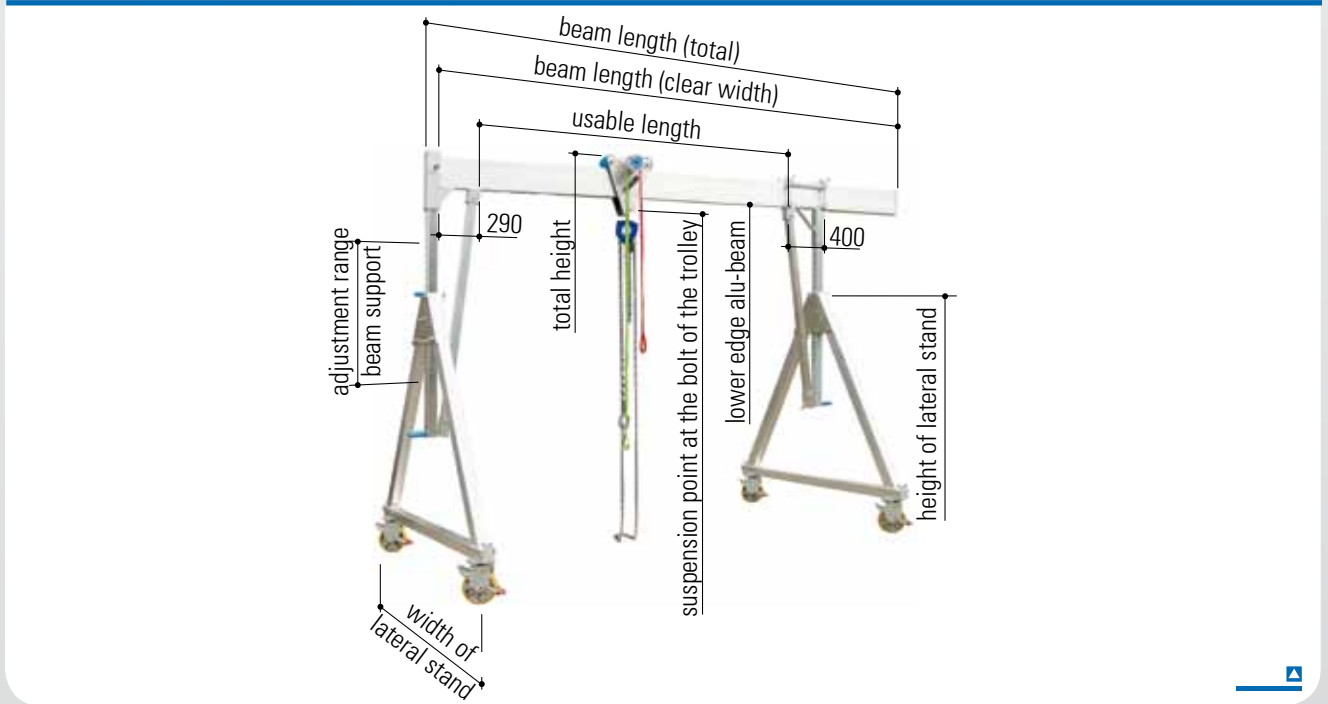

item no.	load capacity	beam length		suspension point at the bolt of the trolley		total height		lower edge alu beam		adjustment range	lateral stand		weight
		clear width	total	min.	max.	min.	max.	min.	max.	beam support	width	height	
	kg	mm	mm	mm	mm	mm	mm	mm	mm	mm	mm	mm	kg
small	Please find details for this Aluminum Gantry Crane on page 32.												
1471040	1,000	4,000	4,100	1,730	2,130	2,110	2,510	1,820	2,220	400	1,490	1,430	167
1471540	1,500	4,000	4,100	1,730	2,130	2,110	2,510	1,800	2,200	400	1,490	1,430	175
medium	Please find details for this Aluminum Gantry Crane on page 33.												
1481040	1,000	4,000	4,100	2,170	3,020	2,550	3,400	2,260	3,110	850	2,000	1,870	189
1481540	1,500	4,000	4,100	2,170	3,020	2,550	3,400	2,240	3,090	850	2,000	1,870	197
high	Please find details for this Aluminum Gantry Crane on page 34.												
1491040	1,000	4,000	4,100	2,500	3,800	2,880	4,180	2,590	3,890	1,300	2,320	2,140	207
1491540	1,500	4,000	4,100	2,500	3,800	2,880	4,180	2,570	3,870	1,300	2,320	2,140	215



Aluminium Gantry Cranes, movable under load, **small**

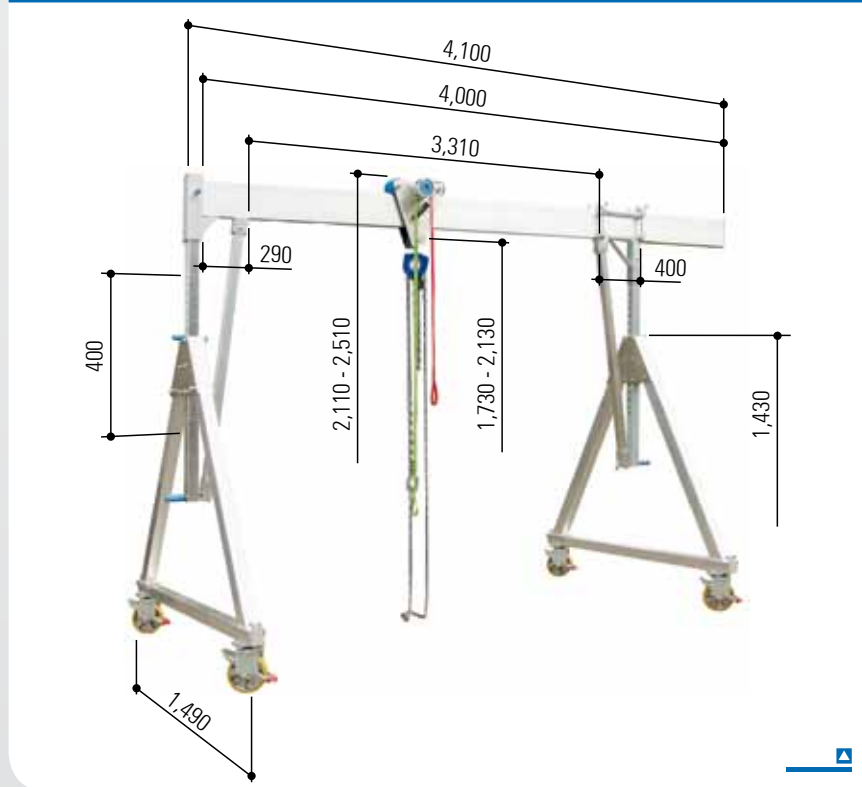

with collapsible lateral stands
incl. park-brake trolley
incl. integrated horizontal adjuster

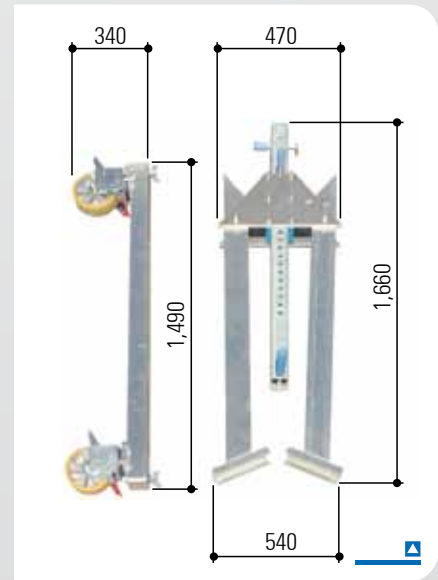

Accessories

- ▣ Wall Bracketpage 78
- ▣ Crane Transporterpage 80
- ▣ Chain Hoistpage 81
- ▣ Electric Chain Hoistpage 82
- ▣ Cable System / Power Supplypage 83
- ▣ Manual Trolley Direction Band ...page 84
- ▣ Hand Winchpage 84
- ▣ Packing and Transportation
Boxpage 86

Alternatives

- ▣ casters with fixed directionpage 35
- ▣ solid rubber tyrespage 35
- ▣ separable resp. pluggable
Aluminium Beampage 36

Technical Data

item no.		1471040	1471540
load capacity	kg	1,000	1,500
beam length	mm	4,000	4,000
beam support	mm	71 x 71	71 x 71
beam profile	mm	200 x 50	220 x 60
beam housing		one side: sleeve 92 x 92 mm, 380 mm long; with connection for brace; other side: end piece	
total weight	kg	167	175
aluminium beam	kg	31	39
lateral stand	kg	2 x 59	2 x 59
trolley	kg	8	8
horizontal adjuster	kg	10	10

Please find an overview of this Aluminium Gantry Crane on page 31.



Aluminium Gantry Cranes, movable under load, **medium**

with collapsible lateral stands
incl. park-brake trolley
incl. integrated horizontal adjuster

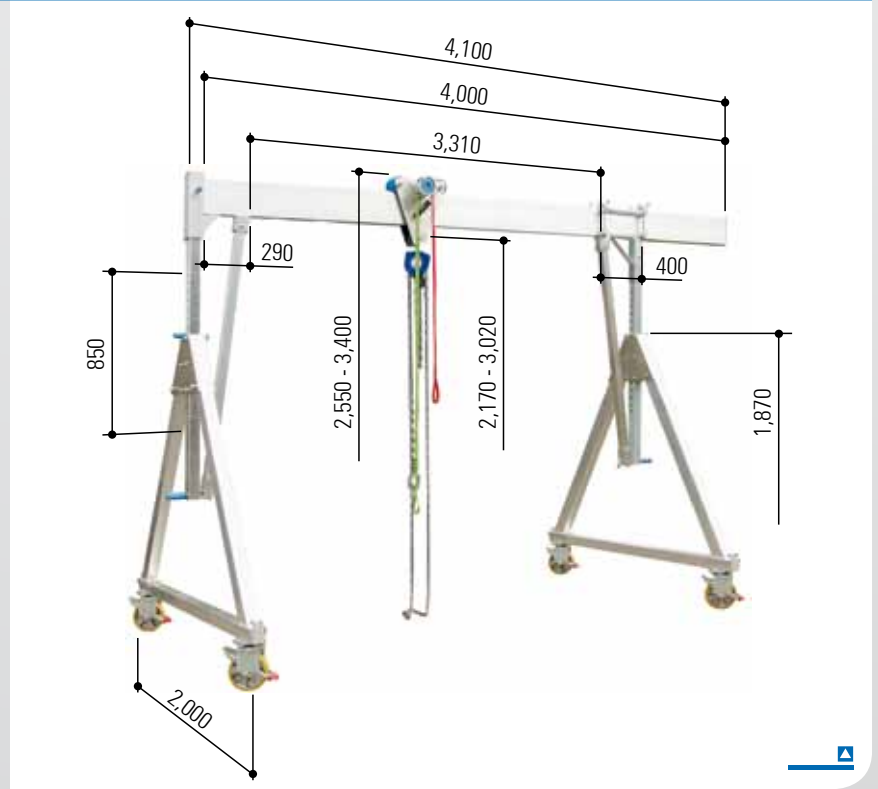
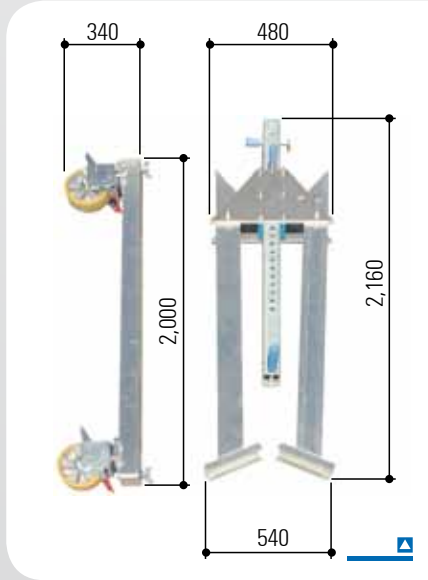

Alternatives

- ▣ casters with fixed directionpage 35
- ▣ solid rubber tyrespage 35
- ▣ separable resp. pluggable Aluminium Beampage 36

Accessories

- ▣ Wall Bracketpage 78
- ▣ Crane Transporterpage 80
- ▣ Chain Hoistpage 81
- ▣ Electric Chain Hoistpage 82
- ▣ Cable System / Power Supply ...page 83
- ▣ Manual Trolley Direction Band ...page 84
- ▣ Hand Winchpage 84
- ▣ Packing and Transportation Boxpage 86

Technical Data

item no.		1481040	1481540
load capacity	kg	1,000	1,500
beam length	mm	4,000	4,000
beam support	mm	71 x 71	71 x 71
beam profile	mm	200 x 50	220 x 60
beam housing		one side: sleeve 92 x 92 mm, 380 mm long; with connection for brace; other side: end piece	
total weight	kg	189	197
aluminium beam	kg	31	39
lateral stand	kg	2 x 70	2 x 70
trolley	kg	8	8
horizontal adjuster	kg	10	10

Please find an overview of this Aluminium Gantry Crane on page 31.



Aluminium Gantry Cranes, movable under load, **high**

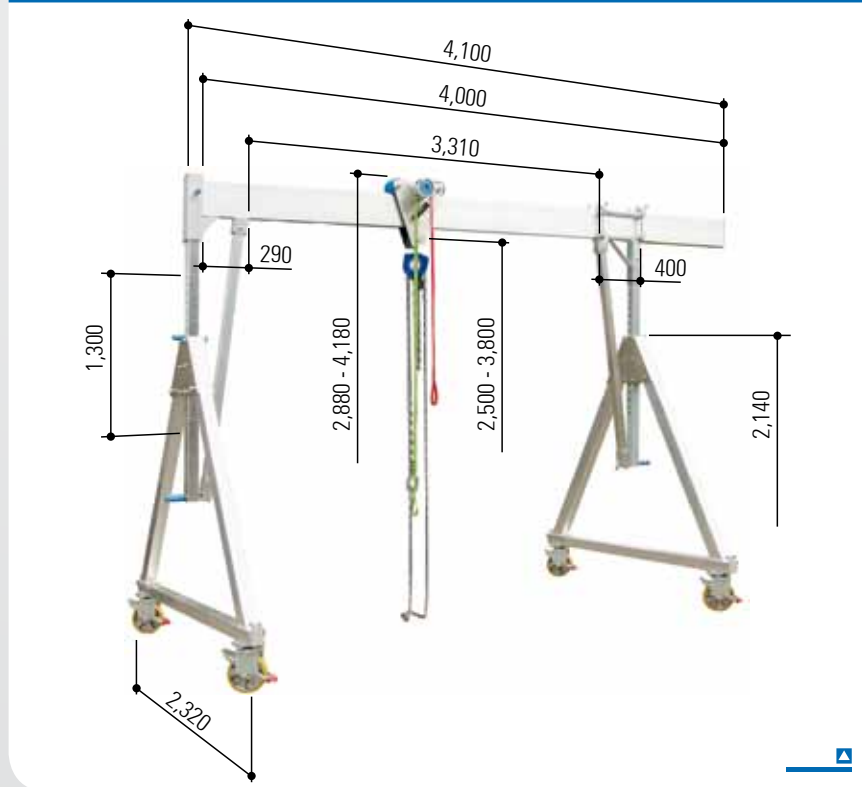

with collapsible lateral stands
incl. park-brake trolley
incl. integrated horizontal adjuster

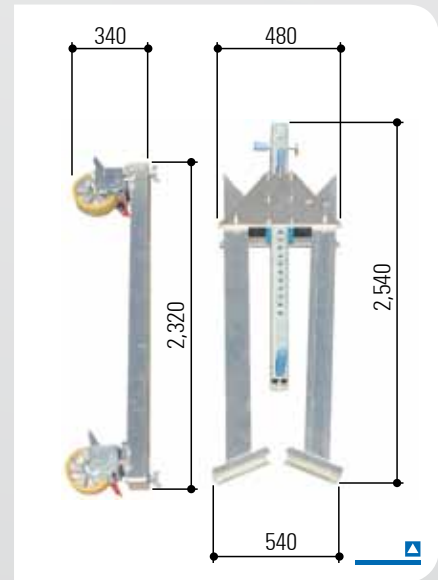

Accessories

- ▣ Wall Bracketpage 78
- ▣ Crane Transporterpage 80
- ▣ Chain Hoistpage 81
- ▣ Electric Chain Hoistpage 82
- ▣ Cable System / Power Supplypage 83
- ▣ Manual Trolley Direction Band ...page 84
- ▣ Hand Winchpage 84
- ▣ Packing and Transportation
Boxpage 86

Alternatives

- ▣ casters with fixed directionpage 35
- ▣ solid rubber tyrespage 35
- ▣ separable resp. pluggable
Aluminium Beampage 36

Technical Data

item no.		1491040	1491540
load capacity	kg	1,000	1,500
beam length	mm	4,000	4,000
beam support	mm	71 x 71	71 x 71
beam profile	mm	200 x 50	220 x 60
beam housing		one side: sleeve 92 x 92 mm, 380 mm long; with connection for brace; other side: end piece	
total weight	kg	207	215
aluminium beam	kg	31	39
lateral stand	kg	2 x 79	2 x 79
trolley	kg	8	8
horizontal adjuster	kg	10	10

Please find an overview of this Aluminium Gantry Crane on page 31.



Aluminium Gantry Cranes, movable under load, capacity 1,000 kg and 1,500 kg

with collapsible lateral stands
incl. park-brake trolley
incl. integrated horizontal adjuster

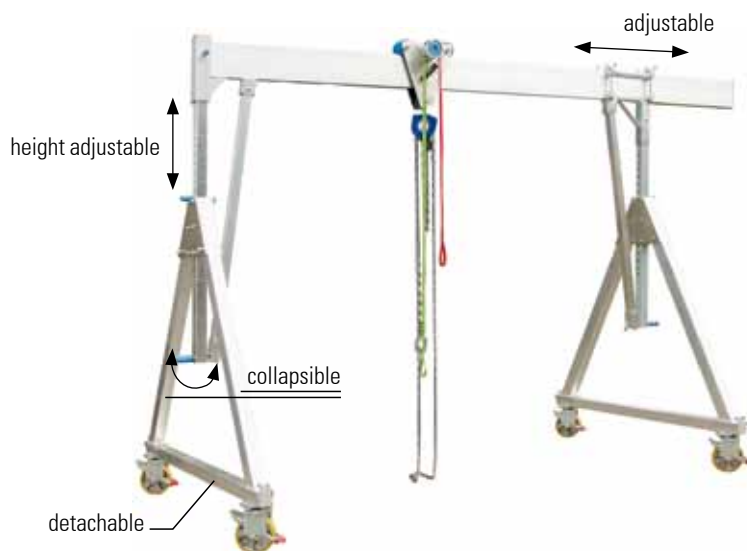

By request our Aluminium Gantry Cranes are also available with the following variety of casters:

fixed direction

- with 4 steel casters
- heavy-duty polyurethane lining
- with integrated caster and live ring brake
- with 4 x 90° fixed direction (please see symbol)
- diameter of caster 200 mm
- width of caster 50 mm

With this combination the Aluminium Gantry Crane can be exactly moved lengthways or laterally. By releasing the fixed direction the Crane can be moved freely. With the use of the brake system the Aluminium Gantry Crane can be secured positioned.

item-no. standard gantry-Ri
e.g. item-no. 1481040-Ri

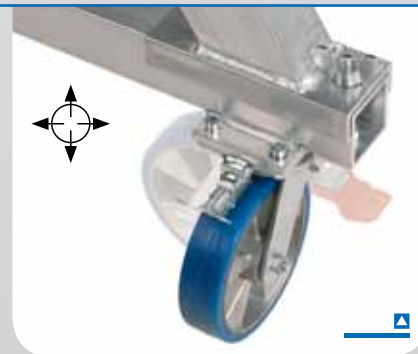

solid rubber tyres

- with 4 steel casters
- with heavy-duty tyres with super-elastic-solid rubber tyres (groove profile)
- 3-komponents-tyres
 - foot of tyre steel wire core - embedded in a resistant rubber compound – guaranteed to fit tightly onto the rim
 - intermediate cushion ensures shock absorption and vibration damping, for favourable rolling resistance

- running surface the thick, abrasion-resistant running surface ensures a long durability
- with integrated caster and live ring brake
- diameter of caster 250 mm
- width of caster 85 mm

These tyres are available for Aluminium Gantry Crane with load capacity 1,000 kg.

item-no. standard gantry-PU
e.g. item-no. 1481040-PU





separable resp. pluggable Aluminium Beam



Picture: Aluminium Gantry Crane, stationary model, with single beam



The Item number consists of:

New Aluminium Gantry Crane: Item number of the standard crane (compare pages 30 to 34) -**10**

Examples:

Aluminium Gantry Crane, movable under load, medium, load capacity 1,000 kg

- ▣ with 'Standard' Aluminium Beam, beam length 4,000 mm: item no. 1481040
- ▣ with 'separable resp. pluggable' Aluminium Beam, beam length 4,000 mm: item no. 1481040-10

The separable resp. pluggable Aluminium Beam!

This latest addition is a consequence of further development of our extensive assortment of Cranes and Accessories. Through our own aspirations in optimisation we now bring you – the separable resp. pluggable Aluminium Beam.

An innovation for our customers

Through your wishes for speed, innovation and optimisation and further more high-end quality products we want to inspire you.

As we are able to offer our aluminium lateral stands with the alternative of being collapsible, we have now taken the longest and most cumbersome part in our delivery programme and enabled it to be separable resp. pluggable Aluminium Beam.

One of the two separated beam pieces can also be used as single Aluminium Beam as well.

Save even more space

- ▣ Purchase a complete Aluminium Gantry Crane including the separable resp. pluggable Aluminium Beam.
- ▣ Upgrade your already existing Aluminium Gantry Crane.

This separable resp. pluggable Aluminium Beam is suitable for Aluminium Gantry Cranes detailed on pages 30 to 35.