

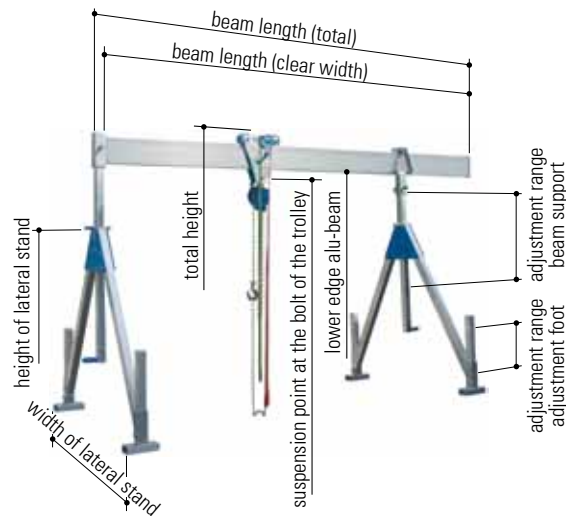

## Aluminium Gantry Cranes, stationary model, load capacity 1,000 kg and 1,500 kg



item no.	load capacity	beam length		suspension point at the bolt of the trolley		total height		lower edge alu beam		adjustment range		lateral stand		weight
		clear width	total	min.	max.	min.	max.	min.	max.	beam support	adjustment foot	width	height	
	kg	mm	mm	mm	mm	mm	mm	mm	mm	mm	mm	mm	mm	kg
<b>small</b>	<b>Please find details for this Aluminum Gantry Crane on page 10.</b>													
1311040	1,000	4,000	4,100	1,260	2,360	1,640	2,740	1,350	2,450	700	400	1,300	1,160	91
1311050	1,000	5,000	5,100	1,260	2,360	1,640	2,740	1,350	2,450	700	400	1,300	1,160	103
1311060	1,000	6,000	6,100	1,260	2,360	1,640	2,740	1,330	2,430	700	400	1,300	1,160	117
1311070	1,000	7,000	7,100	1,260	2,360	1,640	2,740	1,330	2,430	700	400	1,300	1,160	126
1311080	1,000	8,000	8,100	1,260	2,360	1,640	2,740	1,330	2,430	700	400	1,300	1,160	167
1311540	1,500	4,000	4,100	1,260	2,360	1,640	2,740	1,330	2,430	700	400	1,300	1,160	99
1311550	1,500	5,000	5,100	1,260	2,360	1,640	2,740	1,330	2,430	700	400	1,300	1,160	128
1311560	1,500	6,000	6,100	1,260	2,360	1,640	2,740	1,330	2,430	700	400	1,300	1,160	141
<b>medium</b>	<b>Please find details for this Aluminum Gantry Crane on page 11.</b>													
1321040	1,000	4,000	4,100	1,740	2,990	2,120	3,370	1,830	3,080	850	400	1,740	1,540	97
1321050	1,000	5,000	5,100	1,740	2,990	2,120	3,370	1,830	3,080	850	400	1,740	1,540	109
1321060	1,000	6,000	6,100	1,740	2,990	2,120	3,370	1,830	3,080	850	400	1,740	1,540	123
1321070	1,000	7,000	7,100	1,740	2,990	2,120	3,370	1,830	3,080	850	400	1,740	1,540	132
1321080	1,000	8,000	8,100	1,740	2,990	2,120	3,370	1,830	3,080	850	400	1,740	1,540	173
1321540	1,500	4,000	4,100	1,740	2,990	2,120	3,370	1,830	3,080	850	400	1,740	1,540	105
1321550	1,500	5,000	5,100	1,740	2,990	2,120	3,370	1,830	3,080	850	400	1,740	1,540	134
1321560	1,500	6,000	6,100	1,740	2,990	2,120	3,370	1,830	3,080	850	400	1,740	1,540	147
<b>high</b>	<b>Please find details for this Aluminum Gantry Crane on page 12.</b>													
1331040	1,000	4,000	4,100	2,320	4,020	2,700	4,400	2,410	4,110	1,300	400	2,240	1,970	149
1331050	1,000	5,000	5,100	2,320	4,020	2,700	4,400	2,410	4,110	1,300	400	2,240	1,970	161
1331060	1,000	6,000	6,100	2,320	4,020	2,700	4,400	2,390	4,090	1,300	400	2,240	1,970	175
1331070	1,000	7,000	7,100	2,320	4,020	2,700	4,400	2,390	4,090	1,300	400	2,240	1,970	184
1331080	1,000	8,000	8,100	2,320	4,020	2,700	4,400	2,390	4,090	1,300	400	2,240	1,970	225
1331540	1,500	4,000	4,100	2,320	4,020	2,700	4,400	2,390	4,090	1,300	400	2,240	1,970	157
1331550	1,500	5,000	5,100	2,320	4,020	2,700	4,400	2,390	4,090	1,300	400	2,240	1,970	186
1331560	1,500	6,000	6,100	2,320	4,020	2,700	4,400	2,390	4,090	1,300	400	2,240	1,970	199



## Aluminium Gantry Cranes, stationary model, **small**

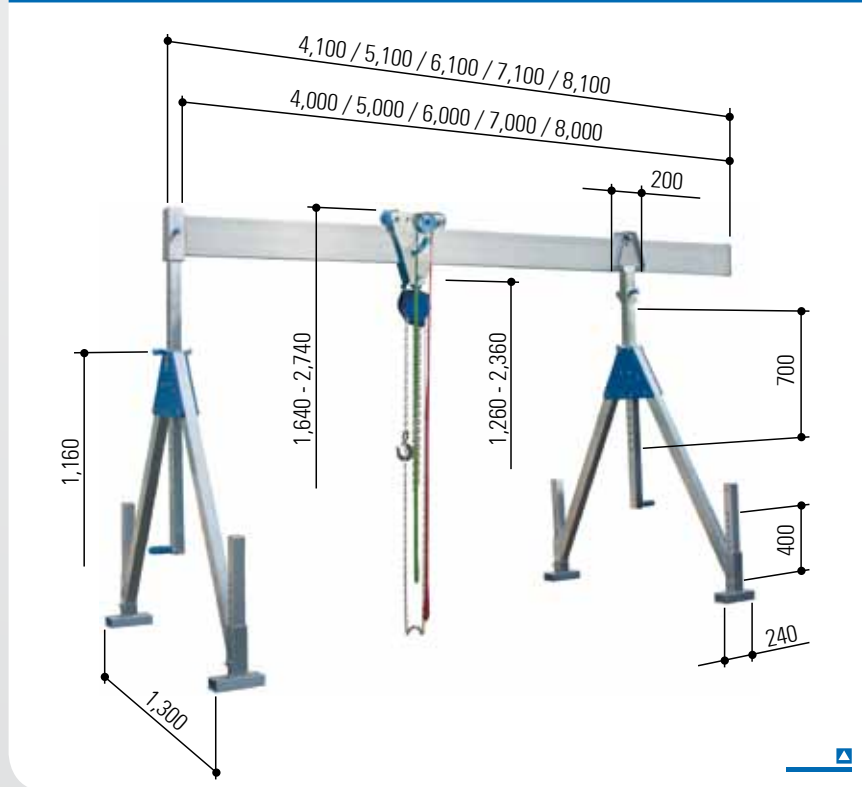

with collapsible lateral stands  
incl. park-brake trolley  
incl. integrated horizontal adjuster

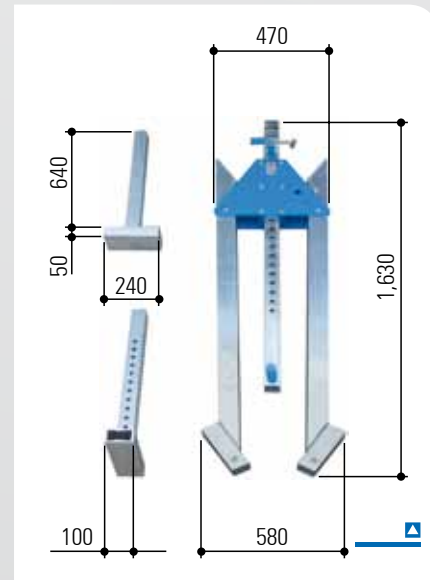

### Accessories

- ▣ Wall Bracket .....page 78
- ▣ Wheel Kit .....page 79
- ▣ Crane Transporter .....page 80
- ▣ Chain Hoist .....page 81
- ▣ Electric Chain Hoist .....page 82
- ▣ Cable System / Power Supply ....page 83
- ▣ Manual Trolley Direction Band ...page 84
- ▣ Hand Winch .....page 84
- ▣ Lateral Extension Beam .....page 85
- ▣ Packing and Transportation  
Box .....page 86

### Alternatives

- ▣ separable resp. pluggable  
Aluminium Beam .....page 13

folded lateral stand



### Technical Data

item no.		1311040	1311050	1311060	1311070	1311080	1311540	1311550	1311560
load capacity	kg	1,000	1,000	1,000	1,000	1,000	1,500	1,500	1,500
beam length	mm	4,000	5,000	6,000	7,000	8,000	4,000	5,000	6,000
beam support	mm	61 x 61	61 x 61	61 x 61	61 x 61	61 x 61	61 x 61	61 x 61	61 x 61
beam profile	mm	200 x 50	200 x 50	220 x 60	220 x 60	220 x 60*	220 x 60	220 x 60*	220 x 60*
beam housing		one side: sleeve 82 x 82 mm, 270 mm long; other side: end piece							
total weight	kg	91	103	117	126	167	99	128	141
aluminium beam	kg	31	43	57	66	107	39	68	81
lateral stand	kg	2 x 24	2 x 24	2 x 24	2 x 24	2 x 24	2 x 24	2 x 24	2 x 24
trolley	kg	8	8	8	8	8	8	8	8
horizontal adjuster	kg	4	4	4	4	4	4	4	4

\* with larger profile thickness (inwards)

Please find an overview of this Aluminium Gantry Crane on page 9.



## Aluminium Gantry Cranes, stationary model, **medium**

with collapsible lateral stands  
incl. park-brake trolley  
incl. integrated horizontal adjuster

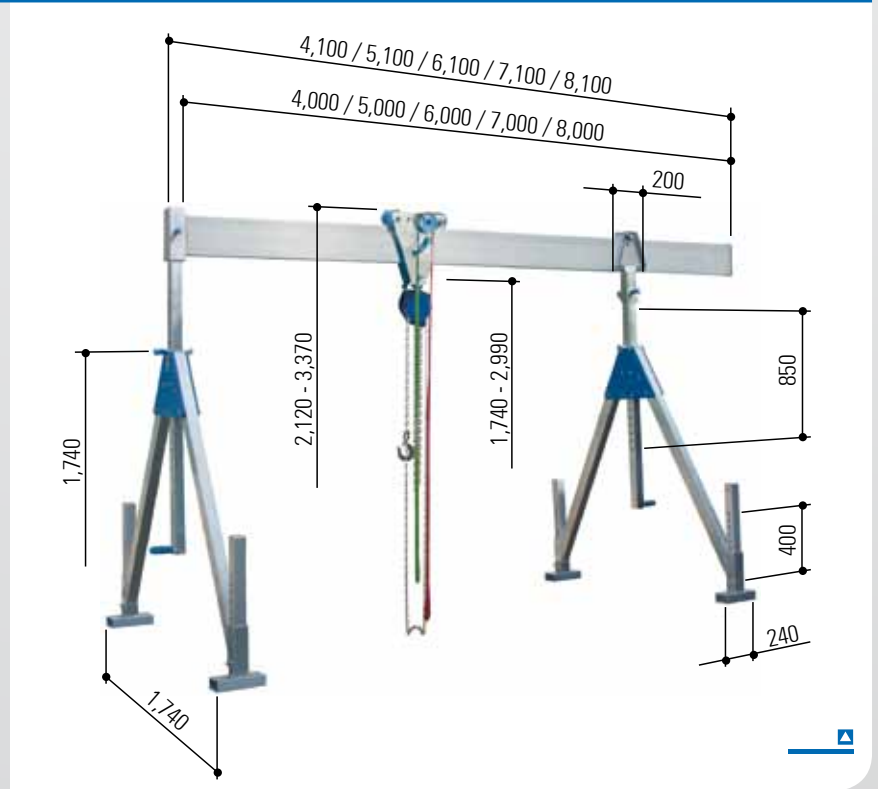
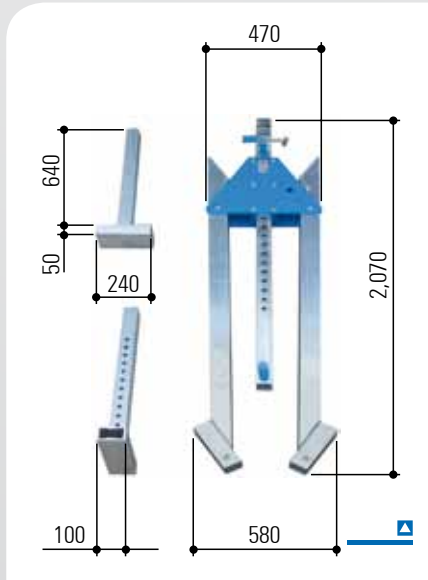

folded lateral stand



### Alternatives

- ▣ separable resp. pluggable Aluminium Beam ..... page 13

### Accessories

- ▣ Wall Bracket ..... page 78
- ▣ Wheel Kit ..... page 79
- ▣ Crane Transporter ..... page 80
- ▣ Chain Hoist ..... page 81
- ▣ Electric Chain Hoist ..... page 82
- ▣ Cable System / Power Supply .... page 83
- ▣ Manual Trolley Direction Band ... page 84
- ▣ Hand Winch ..... page 84
- ▣ Lateral Extension Beam ..... page 85
- ▣ Packing and Transportation Box ..... page 86

### Technical Data

item no.		1321040	1321050	1321060	1321070	1321080	1321540	1321550	1321560
load capacity	kg	1,000	1,000	1,000	1,000	1,000	1,500	1,500	1,500
beam length	mm	4,000	5,000	6,000	7,000	8,000	4,000	5,000	6,000
beam support	mm	61 x 61	61 x 61	61 x 61	61 x 61	61 x 61	61 x 61	61 x 61	61 x 61
beam profile	mm	200 x 50	200 x 50	220 x 60	220 x 60	220 x 60*	220 x 60	220 x 60*	220 x 60*
beam housing		one side: sleeve 82 x 82 mm, 270 mm long; other side: end piece							
total weight	kg	97	109	123	132	173	105	134	147
aluminium beam	kg	31	43	57	66	107	39	68	81
lateral stand	kg	2 x 27	2 x 27	2 x 27	2 x 27	2 x 27	2 x 27	2 x 27	2 x 27
trolley	kg	8	8	8	8	8	8	8	8
horizontal adjuster	kg	4	4	4	4	4	4	4	4

\* with larger profile thickness (inwards)

Please find an overview of this Aluminium Gantry Crane on page 9.



## Aluminium Gantry Cranes, stationary model, high

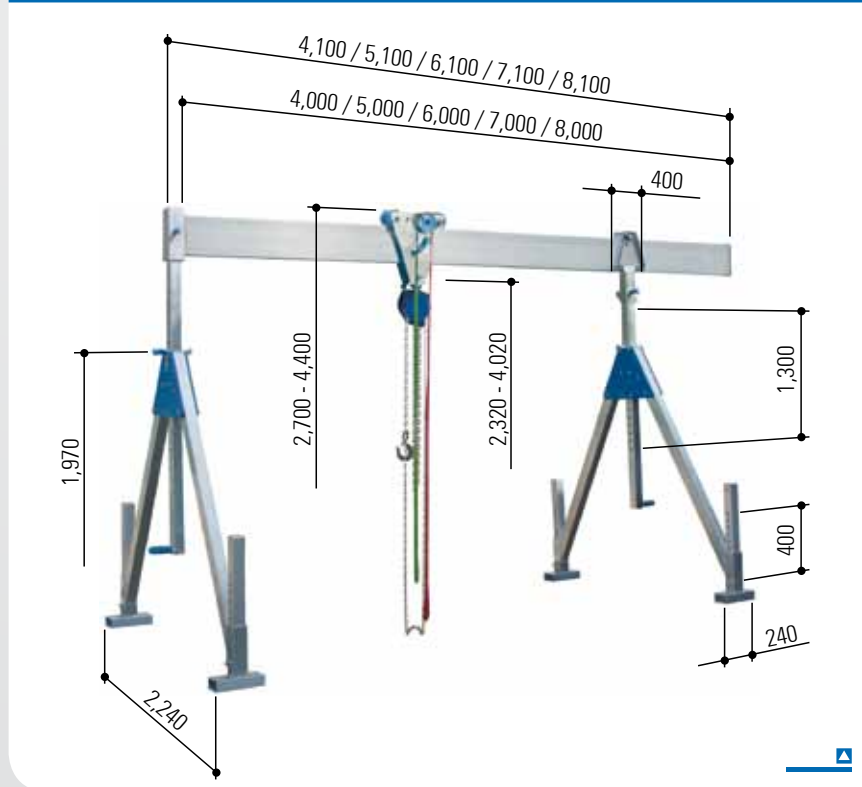

with collapsible lateral stands  
incl. park-brake trolley  
incl. integrated horizontal adjuster

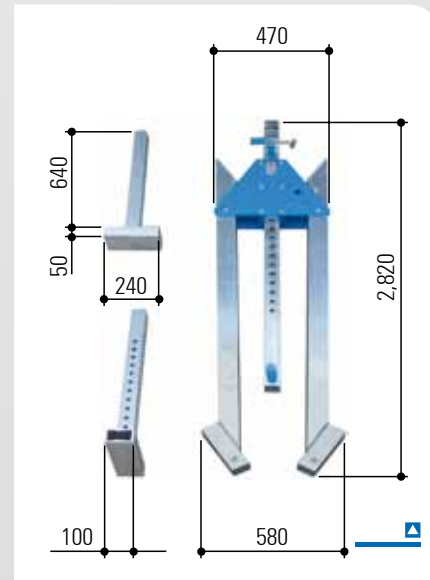

### Accessories

- ▣ Wall Bracket .....page 78
- ▣ Wheel Kit .....page 79
- ▣ Crane Transporter .....page 80
- ▣ Chain Hoist .....page 81
- ▣ Electric Chain Hoist .....page 82
- ▣ Cable System / Power Supply ....page 83
- ▣ Manual Trolley Direction Band ...page 84
- ▣ Hand Winch .....page 84
- ▣ Lateral Extension Beam .....page 85
- ▣ Packing and Transportation  
Box .....page 86

### Alternatives

- ▣ separable resp. pluggable  
Aluminium Beam .....page 13

folded lateral stand



### Technical Data

item no.		1331040	1331050	1331060	1331070	1331080	1331540	1331550	1331560
load capacity	kg	1,000	1,000	1,000	1,000	1,000	1,500	1,500	1,500
beam length	mm	4,000	5,000	6,000	7,000	8,000	4,000	5,000	6,000
beam support	mm	71 x 71	71 x 71	71 x 71	71 x 71	71 x 71	71 x 71	71 x 71	71 x 71
beam profile	mm	200 x 50	200 x 50	220 x 60	220 x 60	220 x 60*	220 x 60	220 x 60*	220 x 60*
beam housing		one side: sleeve 82 x 82 mm, 270 mm long; other side: end piece							
total weight	kg	149	161	175	184	225	157	186	199
aluminium beam	kg	31	43	57	66	107	39	68	81
lateral stand	kg	2 x 50	2 x 50	2 x 50	2 x 50	2 x 50	2 x 50	2 x 50	2 x 50
trolley	kg	8	8	8	8	8	8	8	8
horizontal adjuster	kg	10	10	10	10	10	10	10	10

\* with larger profile thickness (inwards)

Please find an overview of this Aluminium Gantry Crane on page 9.



## separable resp. pluggable Aluminium Beam



### The separable resp. pluggable Aluminium Beam!

This latest addition is a consequence of further development of our extensive assortment of Cranes and Accessories. Through our own aspirations in optimisation we now bring you – the separable resp. pluggable Aluminium Beam.

### An innovation for our customers

Through your wishes for speed, innovation and optimisation and further more high-end quality products we want to inspire you.

As we are able to offer our aluminium lateral stands with the alternative of being collapsible, we have now taken the longest and most cumbersome part in our delivery programme and enabled it to be separable resp. pluggable Aluminium Beam.

Both separated beam pieces can also be used as single Aluminium Beams as well.

### Save even more space

- ▣ Purchase a complete Aluminium Gantry Crane including the separable resp. pluggable Aluminium Beam.
- ▣ Upgrade your already existing Aluminium Gantry Crane.

**This separable resp. pluggable Aluminium Beam is suitable for Aluminium Gantry Cranes detailed on pages 8 to 12.**

### The Item number consists of:

**New Aluminium Gantry Crane:** Item number of the standard crane (compare pages 8 to 12) **-10**

### Examples:

Aluminium Gantry Crane, stationary model, medium, load capacity 1,000 kg

- ▣ with 'Standard' Aluminium Beam, beam length 4,000 mm: item no. 1321040
- ▣ with 'separable resp. pluggable' Aluminium Beam, beam length 4,000 mm: item no. 1321040-10