



YÜKSEK HASSASİYETLİ, PREMIUM TORK EKİPMANLARI "ENDÜSTRİYEL TORK ANAHTARLARI", 1-2000 NM

- ✓ Sürekli tekrarlanabilen torklama hassasiyeti \pm %2
- ✓ Sesli, görüntülü ve kırmızı nokta tork erişim uyarı sistemi
- ✓ İnce ayar derecelendirmeli tork gösterge ayar paneli
- ✓ Cihaza özel seri numarası, fabrika çıkış kalibrasyon sertifikalı
- ✓ Mandal ile her iki yöne çalışan cırcır mekanizması
- ✓ Ergonomik tasarımı tutma ve tork ayar çevirme kolu
- ✓ Hassas ve kısa adımlı torklama işlemlerine uygun tasarım
- ✓ Türkiye'de servis, yedek parça ve kalibrasyon desteği
- ✓ **Made in Germany**

DIN EN ISO 6789:2003 (D) normuna göre;

Skala değerinden sapma \pm %3 6150-1 CT, 6160-1 CT,

Skala değerinden sapma \pm %4 6170-1 CT)

Ergonomik formlu tutma kolu güvenli çalışma olanağı sağlar. Kayma ve yaralanma tehlikesini önler

Tutma kolunda güvenli kilitleme mandalı

Tutma kolunun döndürülmesiyle istenilen tork değerini hızlı, tam ve kolayca ayarlama

Hassas ve yumuşak skala ayarlaması

İnce tasarıma rağmen sağlam ve dayanıklı yapı

Entegre yön seçim mandalı ile tork yükünü serbest bırakma sistemi. 1/2" kare sürücü ile maksimum iş güvenliği

Kullanıcı dostu değiştirilebilir cırcır mekanizması (Yedek parça olarak temin edilebilir)

DIN 3120 A, ISO 1174-1A normlara uygun kare sürücü ölçüleri



Seri numarasına özel kalibrasyon sertifikası



- Şeffaf pencereci muhafaza kutusu -



1 – 6 Nm · 6106-1 CT

Germany Made in Germany



■	Tork Aralığı Nm	Ölçek Nm	Torklama Hassasiyeti	kg		l mm	a mm	b mm
				Min	Max			
6.3 1/4"	1–6	0.1	± 4%	0.7	4.4	197	10.2	24

2 – 10 Nm · 6108-1 CT

Germany Made in Germany



■	Tork Aralığı Nm	Ölçek Nm	Torklama Hassasiyeti	kg		l mm	a mm	b mm
				Min	Max			
6.3 1/4"	2–10	0.2	± 2%	1.4	7.3	198	10.2	24

2 – 10 Nm · 6280-1 CT

Germany Made in Germany



*Sinyal düğmesiz

6401-1

■	Tork Aralığı Nm	Ölçek Nm	Torklama Hassasiyeti	kg		l mm	a mm	b mm
				Min	Max			
9x12	2–10	0.2	± 2%	1.3	6.6	180	17	22

Tork hassasiyeti 6401-1 / 6401-1 S l_z 19,5mm kodlu cırcır kafasıyla ayarlanmıştır.



5 – 13 Nm · 6281-2 CT

Made in Germany

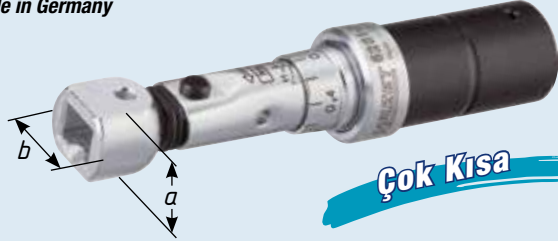

Çok Kısa

9 x 12

• Sinyal düğmesiz



6402-1

■	Tork Aralığı Nm	Ölçek Nm	Torklama Hassasiyeti	kg		l mm	a mm	b mm
				Min	Max			
9 x 12	5-13	0.2	± 4%	4.4	11.8	YALNIZ 125.4	17	22

Tork hassasiyeti 6401-1 / 6401-1 S l₂ 19,5mm kodlu cırcır kafasıyla ayarlanmıştır.

4 – 40 Nm · 6109-2 CT

Made in Germany



6.3 1/4"

• Sinyal düğmesiz

■	Tork Aralığı Nm	Ölçek Nm	Torklama Hassasiyeti	kg		l mm	a mm	b mm
				Min	Max			
6.3 1/4"	4-40	0.4	± 2%	2.0	21.4	256	10.2	24

4 – 40 Nm · 6282-1 CT

Made in Germany



9 x 12

• Sinyal düğmesiz



6402-1

■	Tork Aralığı Nm	Ölçek Nm	Torklama Hassasiyeti	kg		l mm	a mm	b mm
				Min	Max			
9 x 12	4-40	0.4	± 2%	1.9	19.8	240	17	22

Tork hassasiyeti 6401-1 / 6401-1 S l₂ 19,5mm kodlu cırcır kafasıyla ayarlanmıştır.

5 – 60 Nm · 6110-1 CT

 Made in Germany



■	Tork Aralığı Nm	Ölçek Nm	Torklama Hassasiyeti	kg		l mm	a mm	b mm
				Min	Max			
10 3/8	5-60	0.5	± 2 %	1.9	24.7	335	14.5	32

5 – 60 Nm · 6290-1 CT

 Made in Germany



■	Tork Aralığı Nm	Ölçek Nm	Torklama Hassasiyeti	kg		l mm	a mm	b mm
				Min	Max			
9 x 12	5-60	0.5	± 2 %	1.8	23.1	305	17	22

6402-1

Tork hassasiyeti 6402-1 / 6402-1 S l_z 30mm kodlu cırcır kafasıyla ayarlanmıştır.

20 – 120 Nm · 6111-1 CT

 Made in Germany



■	Tork Aralığı Nm	Ölçek Nm	Torklama Hassasiyeti	kg		l mm	a mm	b mm
				Min	Max			
10 3/8	20-120	1	± 2 %	6.7	42.4	389	14.5	32



20 – 120 Nm · 6121-1 CT

Made in Germany



12 5/8"

■	Tork Aralığı Nm	Ölçek Nm	Torklama Hassasiyeti	kg		l mm	a mm	b mm
				Min	Max			
■	20-120	1	± 2 %	6.0	37.4	435	19.6	44

20 – 120 Nm · 6291-2 CT

Made in Germany



9 x 12

6402-1

■	Tork Aralığı Nm	Ölçek Nm	Torklama Hassasiyeti	kg		l mm	a mm	b mm
				Min	Max			
■	20-120	1	± 2 %	5.9	36.7	388	18	23

Tork hassasiyeti 6402-1 / 6402-1 S l₂ 30mm kodlu cırcır kafasıyla ayarlanmıştır.

20 – 120 Nm · 6291-1 CT

Made in Germany



14 x 18

6404-1

■	Tork Aralığı Nm	Ölçek Nm	Torklama Hassasiyeti	kg		l mm	a mm	b mm
				Min	Max			
■	20-120	1	± 2 %	5.6	34.7	400	23	30

Tork hassasiyeti 6404-1 / 6404-1 S l₂ 38,5 mm kodlu cırcır kafasıyla ayarlanmıştır.

40 – 200 Nm · 6122-1 CT

 Made in Germany

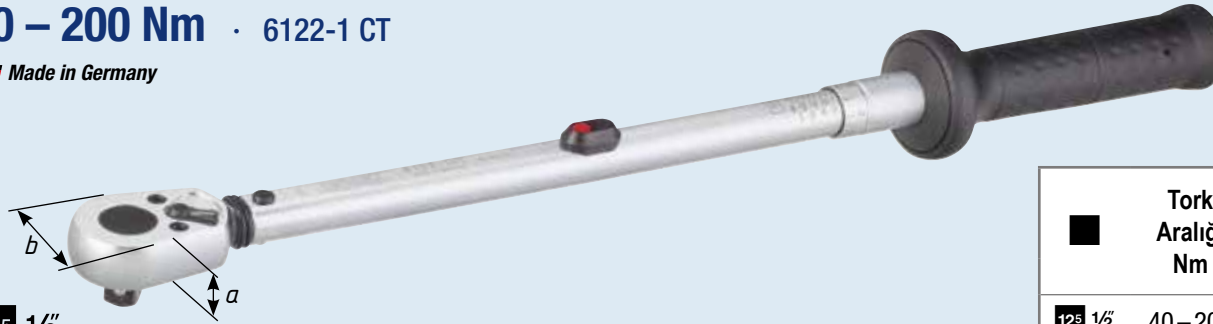

12⁵ 1/2"

■	Tork Aralığı Nm	Ölçek Nm	Torklama Hassasiyeti	kg		l mm	a mm	b mm
				Min	Max			
12 ⁵ 1/2"	40-200	1	± 2 %	9.0	47.5	543	19.6	44

40 – 200 Nm · 6292-1 CT

 Made in Germany

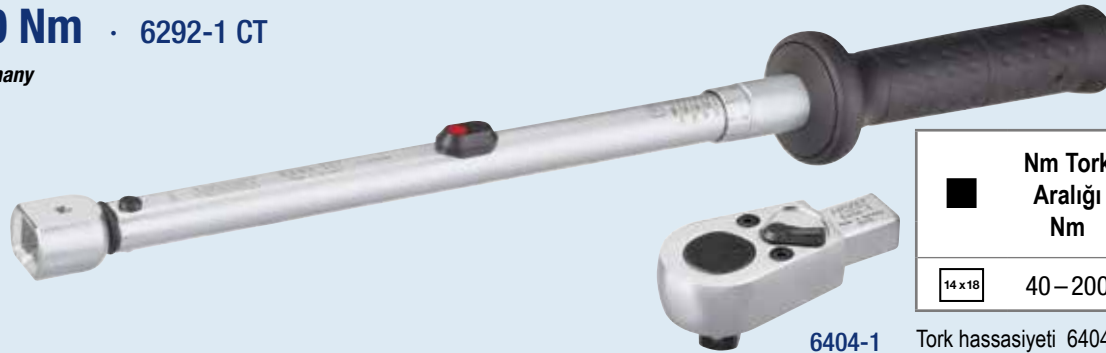

14 x 18

■	Nm Tork Aralığı Nm	Ölçek Nm	Torklama Hassasiyeti	kg		l mm	a mm	b mm
				Min	Max			
14 x 18	40-200	1	± 2 %	10.8	44.9	510	23	30

6404-1

Tork hassasiyeti 6404-1 / 6404-1 S l₂ 38,5 mm kodlu cırcır kafasıyla ayarlanmıştır.

60 – 320 Nm · 6123-1 CT

 Made in Germany

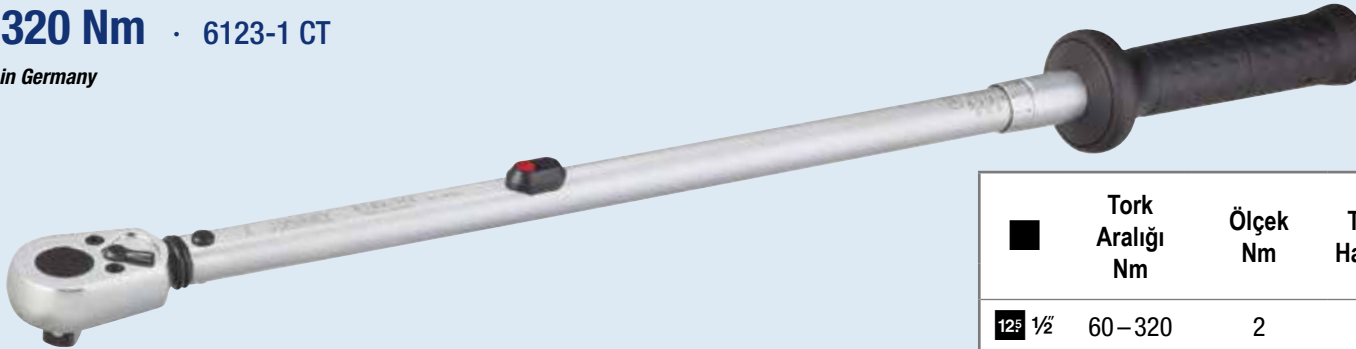

12⁵ 1/2"

■	Tork Aralığı Nm	Ölçek Nm	Torklama Hassasiyeti	kg		l mm	a mm	b mm
				Min	Max			
12 ⁵ 1/2"	60-320	2	± 2 %	10.8	59.6	659	19.6	44



60 – 320 Nm · 6293-1 CT

Made in Germany



14 x 18

■	Tork Aralığı Nm	Ölçek Nm	Torklama Hassasiyeti	kg		l mm	a mm	b mm
				Min	Max			
14 x 18	60-320	2	± 2 %	10.3	56.8	620	23	30

6404-1

Tork hassasiyeti 6404-1 / 6404-1 S l₂ 38,5 mm kodlu cırcır kafasıyla ayarlanmıştır.

100 – 400 Nm · 6143-1 CT

Made in Germany



20 3/4"

• Sinyal düğmesiz

■	Tork Aralığı Nm	Ölçek Nm	Torklama Hassasiyeti	kg		l mm	a mm	b mm
				Min	Max			
20 3/4"	100-400	2.5	± 2 %	14.8	60.2	803	28.5	64

100 – 400 Nm · 6294-1 CT

Made in Germany



14 x 18

• Sinyal düğmesiz

■	Tork Aralığı Nm	Ölçek Nm	Torklama Hassasiyeti	kg		l mm	b mm
				Min	Max		
14 x 18	100-400	2.5	± 2 %	14.9	60.9	715	35.5

6406

Tork hassasiyeti 6406 l₂ 44 mm kodlu cırcır kafasıyla ayarlanmıştır.

200 – 500 Nm · 6144-1 CT

 Made in Germany

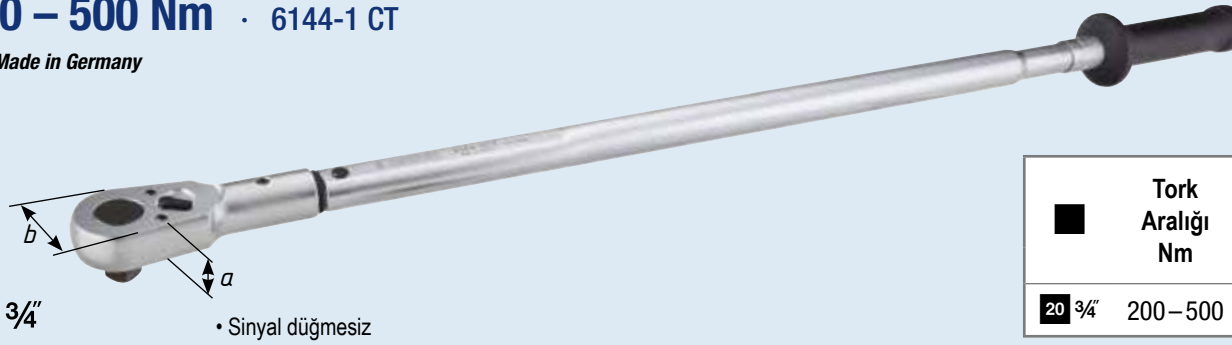

20 3/4"

• Sinyal düğmesiz

■	Tork Aralığı Nm	Ölçek Nm	Torklama Hassasiyeti	kg		l mm	a mm	b mm
				Min	Max			
20 3/4"	200–500	2.5	± 2 %	21.8	55.3	1040	28.5	64

200 – 500 Nm · 6295-1 CT

 Made in Germany

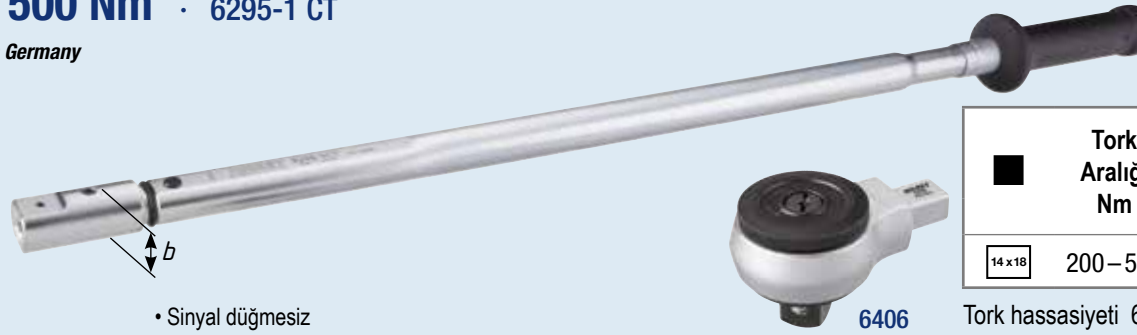

14 x 18

• Sinyal düğmesiz

6406

■	Tork Aralığı Nm	Ölçek Nm	Torklama Hassasiyeti	kg		l mm	b mm
				Min	Max		
14 x 18	200–500	2.5	± 2 %	22.0	55.8	955	35.5

Tork hassasiyeti 6406 l₂ 44 mm kodlu cırcır kafasıyla ayarlanmıştır.

300 – 800 Nm · 6145-1 CT

 Made in Germany

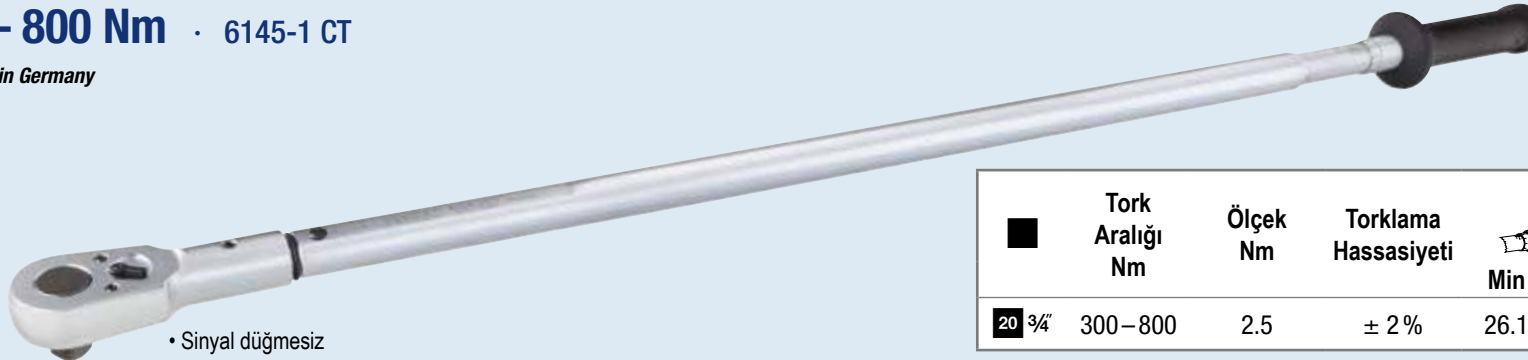

20 3/4"

• Sinyal düğmesiz

■	Tork Aralığı Nm	Ölçek Nm	Torklama Hassasiyeti	kg		l mm	a mm	b mm
				Min	Max			
20 3/4"	300–800	2.5	± 2 %	26.1	70.9	1280	28.5	64



300 – 800 Nm · 6296-1 CT

Made in Germany



14 x 18

• Sinyal düğmesiz



6406

■	Tork Aralığı Nm	Ölçek Nm	Torklama Hassasiyeti	kg		l mm	b mm
				Min	Max		
14 x 18	300–800	2.5	± 2 %	26.3	71.3	1195	35.5

Tork hassasiyeti 6406 l_z 44 mm kodlu cırcır kafasıyla ayarlanmıştır.

400 – 1000 Nm · 6150-1 CT

Made in Germany

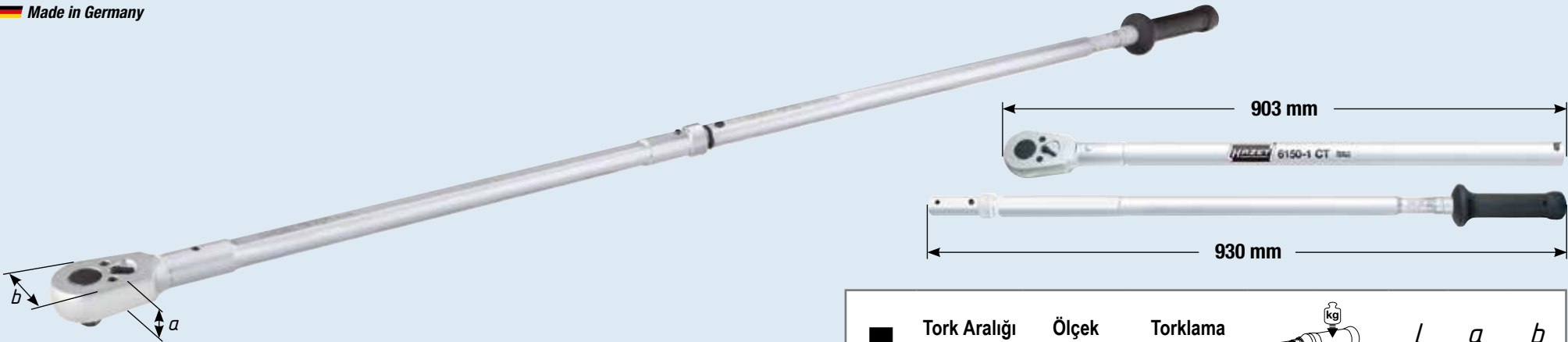

20 3/4"

• Sinyal düğmesiz

■	Tork Aralığı Nm	Ölçek Nm	Torklama Hassasiyeti	kg		l mm	a mm	b mm
				Min	Max			
20 3/4"	400–1000	5	± 3 %	24.1	60.7	1788	36	77

600 – 1600 Nm · 6160-1 CT

 Made in Germany

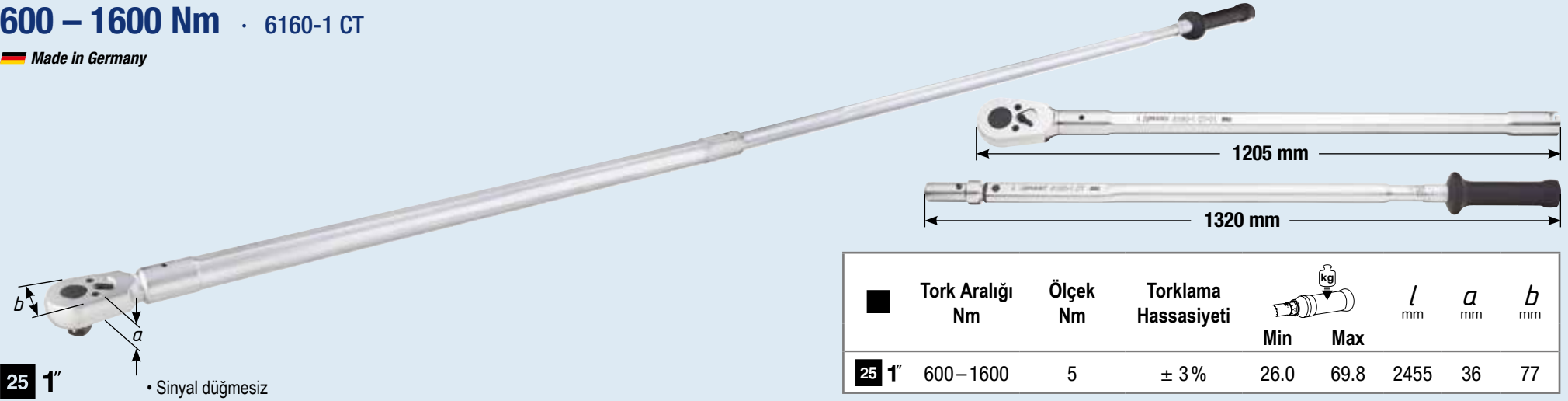

25 1" • Sinyal düğmesiz

■	Tork Aralığı Nm	Ölçek Nm	Torklama Hassasiyeti	kg		l mm	a mm	b mm
				Min	Max			
25 1"	600-1600	5	± 3%	26.0	69.8	2455	36	77

800 – 2000 Nm · 6170-1 CT

 Made in Germany

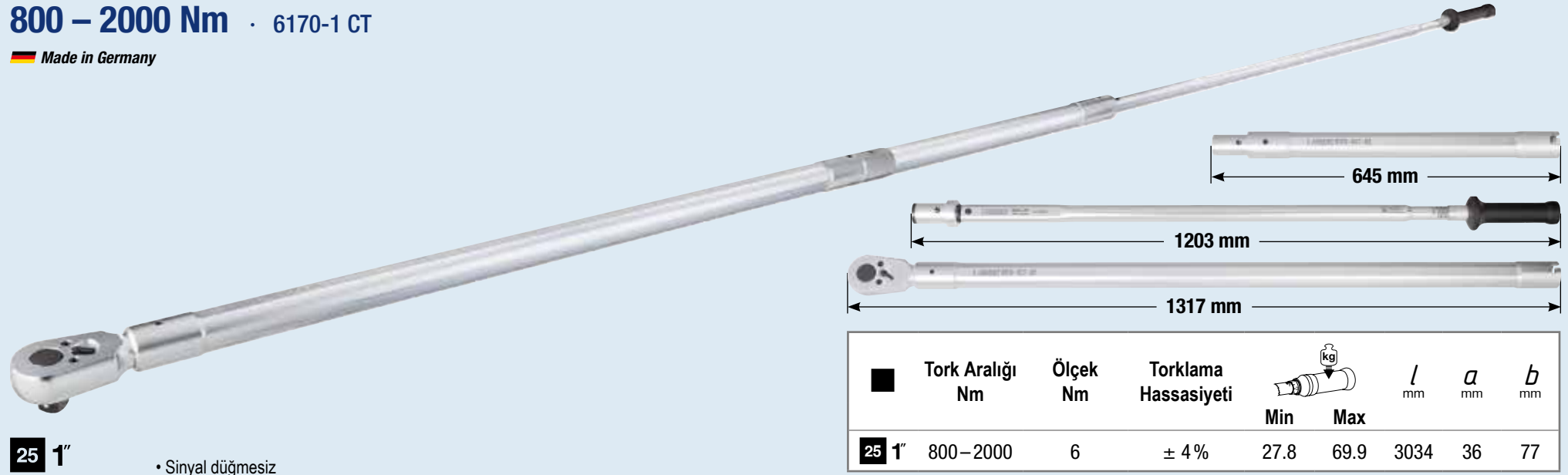

25 1" • Sinyal düğmesiz

■	Tork Aralığı Nm	Ölçek Nm	Torklama Hassasiyeti	kg		l mm	a mm	b mm
				Min	Max			
25 1"	800-2000	6	± 4%	27.8	69.9	3034	36	77