



DLR Serisi Hidrolik Katlanabilir Atölye Vinçleri

DLR Portable Hydraulic Cranes



- » 650 kg, 1 ton ve 2 ton olmak üzere üç farklı model.
- » 700 bar hidrolik çalışma sisteminde maksimum güvenlik.
- » Kapasitesinin üzerindeki yüke karşı emniyet sistemi.
- » Ağır yüke dayanıklı yapı, ergonomik uzun ömürlü tasarım.
- » Manevra kabiliyeti yüksek frenli tekerlek mekanizması.
- » Katlanabilme özelliği ile küçük hacimde toplanabilme.
- » Özel valfi sayesinde güvenli ve kontrollü yük boşaltma.
- » Kontrol dışı yük indirmede otomatik devreye giren kilit sistemi.

- » From 650 to 2.000 kg lifting capacity.
- » Heavy duty wheels and swivel rear castor for easy movement.
- » Exceptionally versatile due to their compact dimensions when folded up.
- » Fitted with a safety relief valve to prevent overloading.
- » All models are fitted with an extendable jib to increase reach.
- » Special lowering valve in all models for safer and better control of descent.
- » If the knob is released accidentally, the arm stops.

| Teknik Bilgiler Technical Info | Birimler Units | DLR006 | DLR010 | DLR020 |
|---|-------------------|--------|--------|--------|
| Kaldırma Kapasitesi Total Capacity | kg | 650 | 1000 | 2000 |
| Askı Kanca Yüksekliği (max) (I) Maximum Hook Height | mm | 2200 | 2200 | 2460 |
| Maks. Boomda Kaldırma Kapasitesi Maximum Capacity at End Point | kg | 350 | 700 | 1250 |
| Vincin Toplam Ağırlığı Total Weight | kg | 83 | 99 | 175 |
| A | mm | 1580 | 1580 | 1740 |
| B | mm | 1480 | 1580 | 1920 |
| C | mm | 1300 | 1300 | 1610 |
| D | mm | 960 | 960 | 1200 |
| E | mm | 112 | 112 | 150 |
| I | mm | 2200 | 2200 | 2460 |
| L | mm | 820 | 970 | 1080 |
| N | mm | 530 | 530 | 700 |

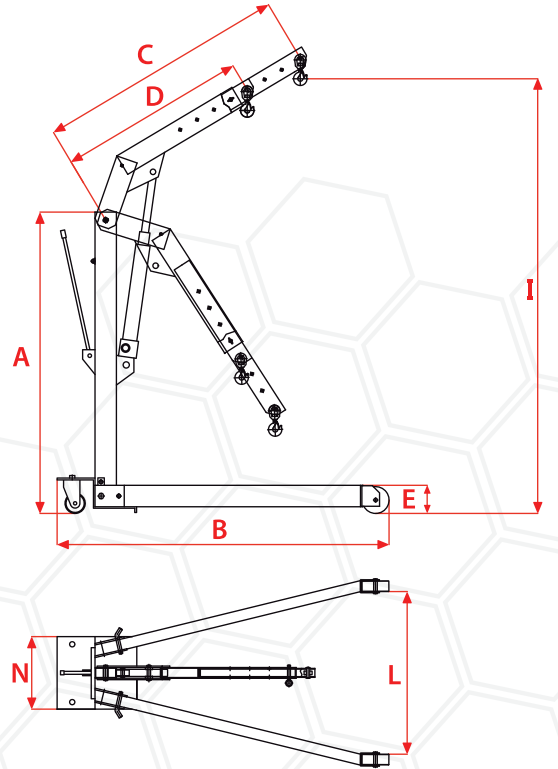

Boom pozisyonuna göre taşıma kapasitesi
Jib Position

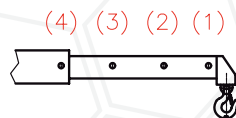

| Model | 4 / 3 / 2 / 1 (Boom pozisyonu) Jib position |
|---------------|--|
| LARZEP | kg |
| DLR006 | 650 - 550 - 450 - 350 |
| DLR010 | 1000 - 900 - 800 - 700 |
| DLR020 | 2000 - 1750 - 1650 - 1250 |

